

# IS31LT3505

## Constant Current, Step-Up LED Driver Evaluation Board Guide

### Description

IS31LT3505 is a constant current boost converter with an internal NMOS. The device topology allows for series type connections of white LEDs, with identical output currents for each channel. This allows for consistent, uniform lighting output and it also ensures that any linked system components receive their respective voltage source(s). The LED current can be adjusted by tuning an external resistor. Dimming of the panel is achieved through Pulse-width-modulation (PWM) or through a DC voltage signal. The driver features a 1MHz switching frequency. Feedback voltage is set at 0.3V to minimize power drain. Safety features of the device include Over-voltage Protection, Over-temperature Protection, and Open-circuit LED protection. This ensures that the chip will maintain a maximum level of reliability for the overall system, even under abnormal situations such as when no load is present. IS31LT3505 may be used in a versatile array of general lighting applications.

### Features

- Supply Voltage: 6V to 30V
- Efficiency: 90% (typical)
- PWM or DC Voltage Dimming Control
- 1.0MHz Switching Frequency
- 35V High-powered Internal NMOS
- Open-circuit LED Protection
- Over-temperature, voltage Protection
- Package: MSOP-10

### Recommended Equipment

- 30VDC Supply
- LED panel/array (1W LED, 9 LEDs in series)
- Multi-meter

### Order information

Part Number	Description	Package
IS31LT3505-SLS2-EBDC	6-30V Input Voltage, <1000mA. Output: $V_{IN}/0.9$	MSOP-10

Table 1: Ordering Information for IS31LT3505 Evaluation Board

**For information about ordering, deliveries, and pricing, please contact ISSI at [analog\\_mkt@issi.com](mailto:analog_mkt@issi.com) or (408)969-6600.**

### Quick Start

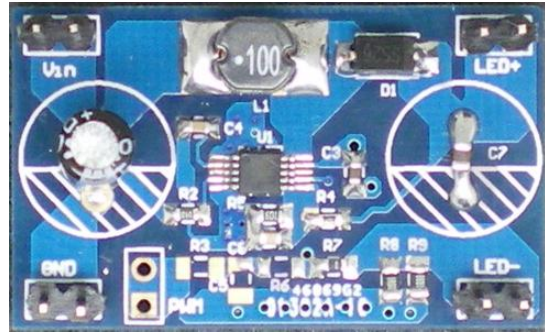

Figure 1: Picture of IS31LT3505-SLS2-EBDC

### Recommended I/O Ratings

- Input Voltage: 10-25VDC
- Output Current: 4-9 LEDs (series) - 350mA/Ch.

**Note:** The input voltage must be  $10\% \cdot V_{OUT}$  lower than the output voltage ( $\Sigma V_F$ ) and input average current should be  $\leq 1000\text{mA}$ .

### Absolute Maximum Ratings

- Input voltage  $\leq 30\text{VDC}$

**Caution:** Do not exceed the conditions listed above, otherwise the board will be damaged.

### Procedure

Follow the steps listed below to verify board operation.

**Caution:** Do not turn on the power supply until all connections are completed.

- 1) Connect the negative terminal of the power supply to the GND pin and the positive terminal to the  $V_{IN}$  pin.
- 2) Connect the negative end of the LED panel (LED arrays) to the LED- terminal.
- 3) Connect the positive end of the LED panel (LED arrays) to the LED+ terminal.
- 4) Turn on the power supply and the LED panel (LED arrays) will turn on.

# IS31LT3505

## Constant Current, Step-Up LED Driver Evaluation Board Guide

### Typical Application Circuit Diagram

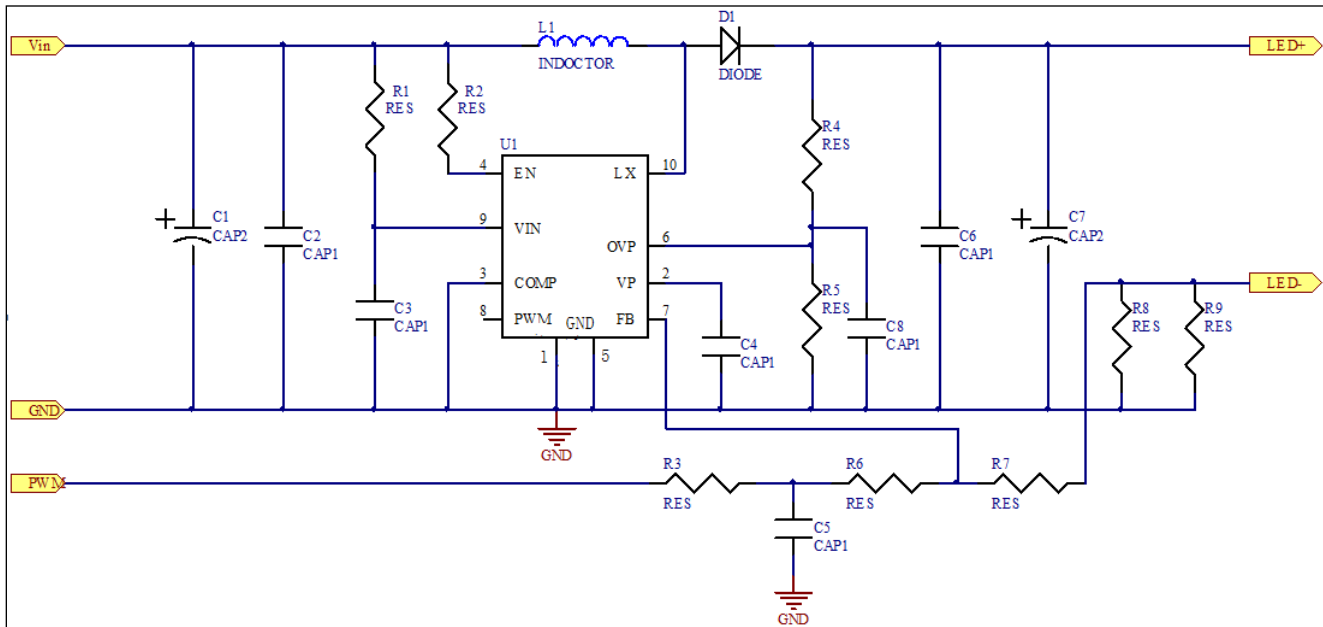

Figure 2: IS31LT3505 Schematic \*Note that components R3, C5, R6 and R7 are used to control dimming of the device.

### Bill of Materials

No.	Name	Description	Symbol	Quantity	Supplier
1	AL Capacitor	22 $\mu$ F $\pm$ 10%,50V	C1	1	
2	SMD Capacitor	4.7 $\mu$ F $\pm$ 20%,50V,0805	C7	1	
3	SMD Capacitor	1 $\mu$ F $\pm$ 20%,50V,0805	C2,C6	2	
4	SMD Capacitor	220nF $\pm$ 20%,50V,0805	C3	1	
5	SMD Capacitor	NC	C5	1	
6	SMD Capacitor	100nF $\pm$ 20%,50V,0805	C4	1	
7	SMD Capacitor	10nF $\pm$ 20%,50V,0603	C8	1	
8	SMD Resistor	51 $\Omega$ $\pm$ 5%,0805	R1	1	
9	SMD Resistor	100K $\Omega$ $\pm$ 5%,0805	R2	1	
10	SMD Resistor	NC	R3,R6	2	
11	SMD Resistor	330K $\Omega$ $\pm$ 1%,0805	R4	1	
12	SMD Resistor	10K $\Omega$ $\pm$ 1%,0805	R5	1	
13	SMD Resistor	0 $\Omega$ , 0805	R7	1	
14	SMD Resistor	1.6 $\Omega$ $\pm$ 1%,0805	R8	1	
15	SMD Resistor	1.8 $\Omega$ $\pm$ 1%,0805	R9	1	
16	Schottky Diode	SS26,2A,60V,SMA	D1	1	
17	SMD Inductor	10 $\mu$ H, I <sub>SET</sub> $\geq$ 2000mA	L1	1	
18	IC	IS31LT3505, MSOP-10 package	U1	1	ISSI

Table 2: Bill of Materials for IS31LT3505 Evaluation Board



## IS31LT3505

# Constant Current, Step-Up LED Driver Evaluation Board Guide

---

## Device Operation

---

### Component Selection

The component selection is very important. They have a significant effect on the operating state of the demo board. The output capacitor must be a low ESR capacitor so as to minimize its affect on the line regulation and load regulation. Please read the datasheet carefully to get more information about the component selection.

### LED Current Control

The IS31LT3505 regulates the LED current by setting the external resistor connecting to feedback and ground. The internal feedback reference voltage is 0.3V (Typical) The LED current can be set from the Formula (1) easily.

$$I_{LED} = V_{FB}/R_{SET}$$

Where:  $R_{SET} = R8 // R9$

In order to have an accurate LED current, precision resistors must be used (1% is recommended).

### PCB layout consideration

As for all switching power supplies, especially those providing high current and using high switching frequencies, layout is an important design step. If layout is not carefully done, the regulator could show instability as well as EMI problems.

- Wide traces should be used for connection of the high current loop.
- When laying out signal ground (pin 5), it is recommended to use the traces separate from power ground (pin1) traces and connect them together at the input capacitor negative terminal or the large ground plane that will avoid the signal ground shift. Pin 3 GND must be connected to signal ground(pin 5). Both of signal and power ground should be as wide as possible. Other components ground must be connected to signal ground. Especially the RSET ground to signal ground (pin 5) connection should be as short as possible to have an accurate LED current.
- The capacitor  $C_{VDD}$  and  $C_{VP}$  should be placed as close as possible to VDD and VP pin for good filtering.
- LX pin is a fast switching node. The inductor and diode should be placed as close as possible to the switch pin and the connection between this pin to the inductor and the schottky diode should be kept as short and wide as possible. Avoid other traces cross and routing too long in parallel with this node to minimum the noise coupling into these traces.
- The feedback network (FB, OVP) should be as short as possible and routed away from the inductor, the schottky diode and LX pin. The feedback pin and feedback network should be shielded with a ground plane or trace to minimize noise coupling into this circuit.
- The thermal pad on the back of package must be soldered to the large ground plane for ideal power dissipation.

# IS31LT3505

## Constant Current, Step-Up LED Driver Evaluation Board Guide

### PCB Layout Guidelines

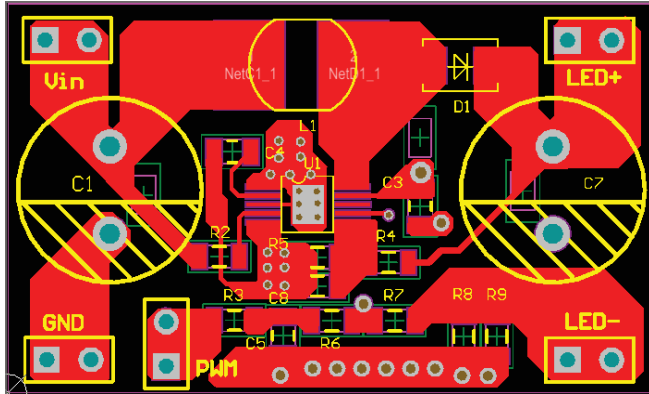

Figure 3: Board PCB Layout- Top Layer

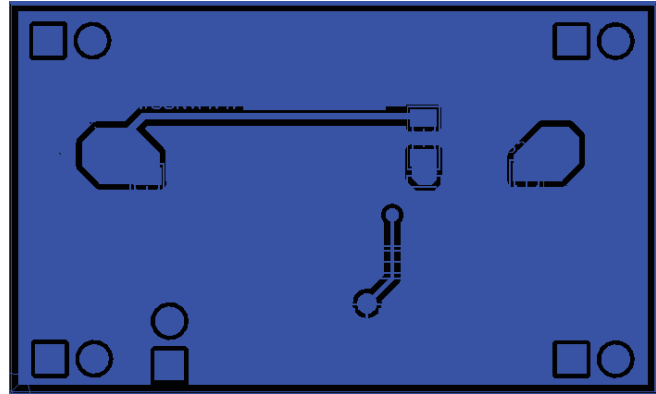

Figure 4: Board PCB Layout-Bottom Layer

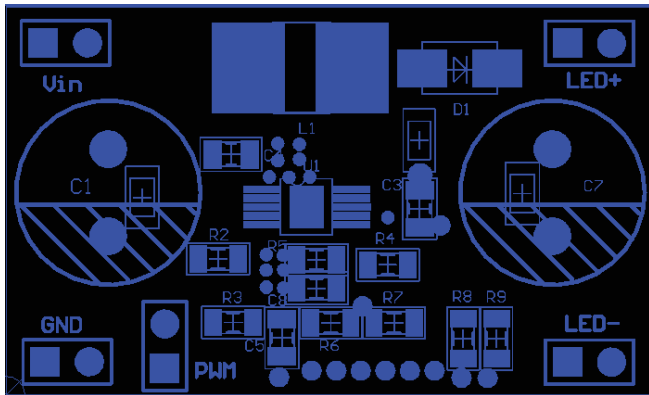

Figure 5: Component Placement Guide- Top Layer

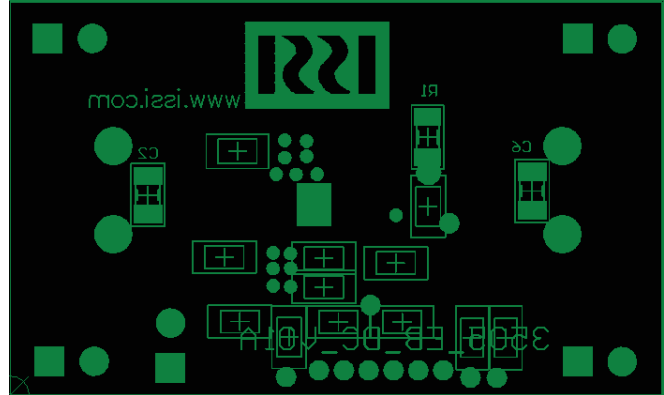

Figure 6: Component Placement Guide- Bottom Layer

Copyright © 2011 Integrated Silicon Solution, Inc. All rights reserved. ISSI reserves the right to make changes to this specification and its products at any time without notice. ISSI assumes no liability arising out of the application or use of any information, products or services described herein. Customers are advised to obtain the latest version of this device specification before relying on any published information and before placing orders for products.

Integrated Silicon Solution, Inc. does not recommend the use of any of its products in life support applications where the failure or malfunction of the product can reasonably be expected to cause failure of the life support system or to significantly affect its safety or effectiveness. Products are not authorized for use in such applications unless Integrated Silicon Solution, Inc. receives written assurance to its satisfaction, that:

- a.) the risk of injury or damage has been minimized;
- b.) the user assume all such risks; and
- c.) potential liability of Integrated Silicon Solution, Inc is adequately protected under the circumstances.

