

Board Level Heat Sinks

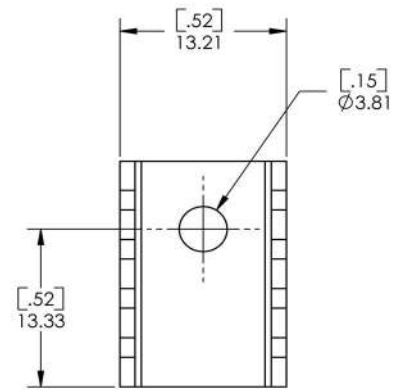

ThermaFlo

P/N: 821002B00000

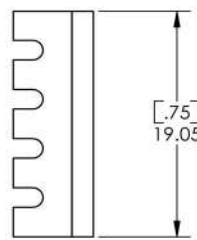
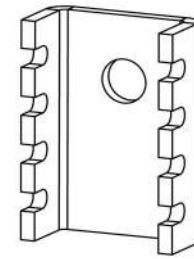
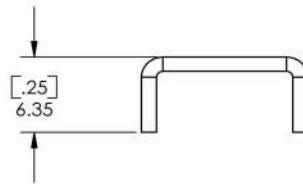
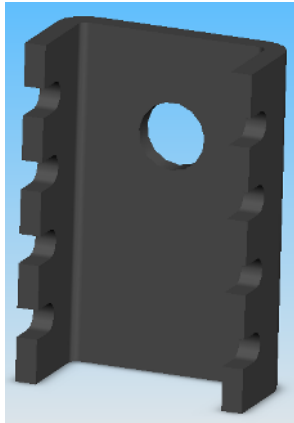

PRODUCT SPECIFICATIONS

- Devices: TO-220
- Size: 6.4 x 13.2 x 19.1 mm
- Material: Aluminum, 1.2 mm Thick
- Type: Stamped
- Weight: 1.3 grams
- PCB Mounting: Solderable Device Leads
- Finish: Black Anodized
- Package: Bulk
- Accessories: Hardware & Thermal Interface Material

FEATURES & BENEFITS

- Hole for Device Attachment
- RoHS Compliant



CUSTOMIZED HEATSINKS

- Specialized Plating
- Specialized Body Configurations
- Contact Applications Engineering

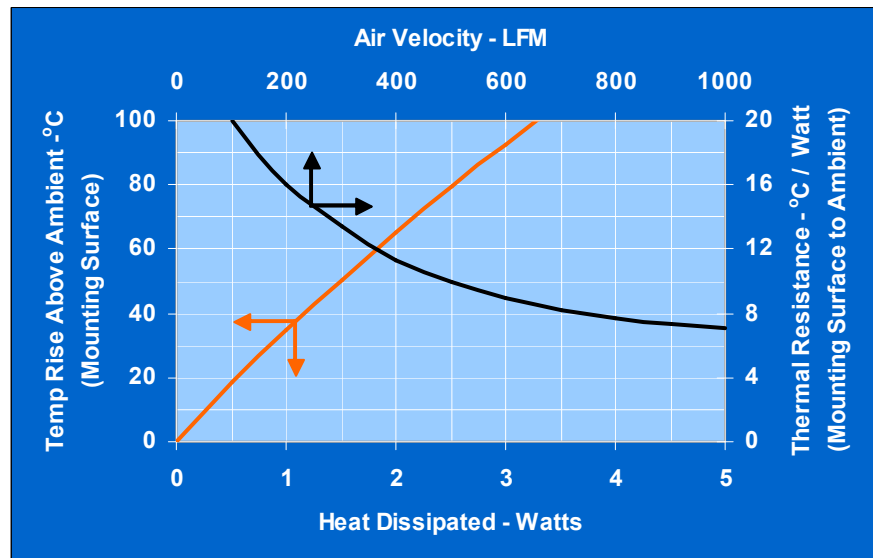

TO-220

COMAIR ROTRON, INC
 8929 Terman Court, San Diego, CA 92121
 Ph (858) 348-6200 Fax (858) 566-4577
 E-mail: sales@comairrotron.com,
 Web: www.comairrotron.com