

**SPECIFICATIONS:**

**ELECTRICAL:**

CURRENT RATING:	5 AMPS
CONTACT RESISTANCE:	15 mOhms MAX.
INSULATION RESISTANCE:	1,000 MOhms MIN.
OPERATING TEMPERATURE:	-50°C TO +100°C
VOLTAGE:	500 VAC FOR 1 MINUTE

**MATERIALS:**

FRONT INSULATOR:	PBT-BLACK, UL94V-0 RATED
REAR INSULATOR:	PA66-BLACK, UL94V-0 RATED
PROCESS TEMP:	230°C
SHELL:	NICKEL PLATED STEEL

**COMPATIBLE WITH NORCOMP CONTACT PART NUMBERS BELOW:**

170-001-170L001	170-101-170L001
170-001-170L002	170-101-170L002
170-001-170L003	170-101-170L003
170-201-170L003	

**\*\*NOTE: CONTACTS MUST BE PURCHASED SEPARATELY\*\***

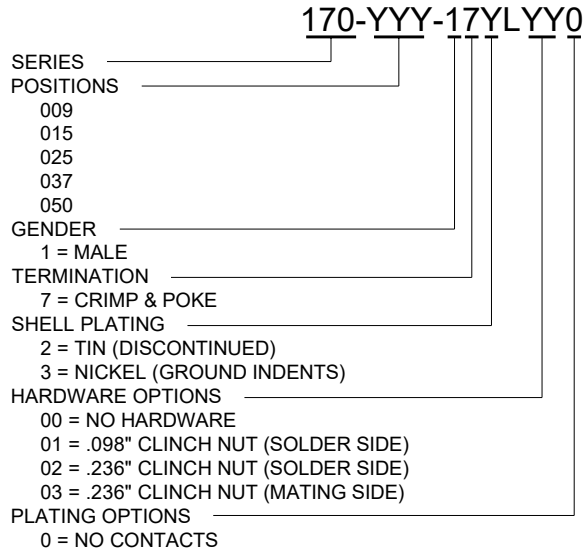
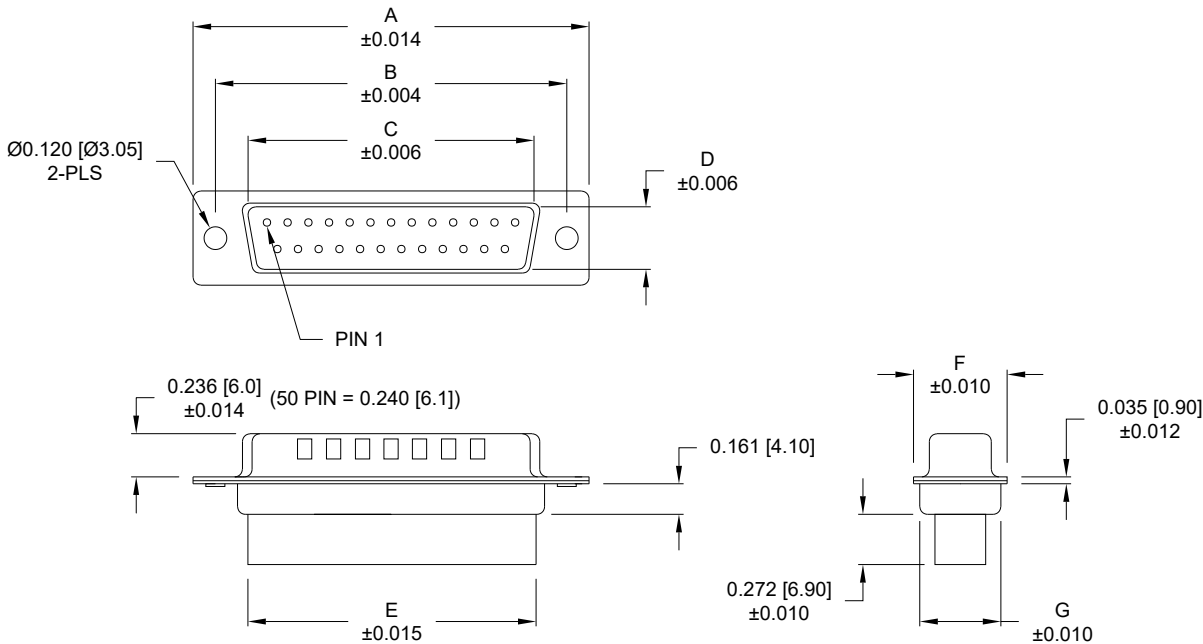

**DIMENSIONS**

No. OF PINS	UNITS	DIMENSIONS						
		A	B	C	D	E	F	G
9	inch	1.213	0.984	0.666	0.329	0.618	0.496	0.429
	mm	30.80	24.99	16.92	8.36	15.70	12.60	10.90
15	inch	1.541	1.312	0.994	0.329	0.933	0.496	0.429
	mm	39.15	33.32	25.25	8.36	23.70	12.60	10.90
25	inch	2.087	1.852	1.534	0.329	1.496	0.496	0.429
	mm	53.00	47.04	38.96	8.36	38.00	12.60	10.90
37	inch	2.728	2.500	2.182	0.329	2.142	0.496	0.429
	mm	69.30	63.50	55.42	8.36	54.40	12.60	10.90
50	inch	2.638	2.402	2.079	0.436	2.039	0.602	0.535
	mm	67.00	61.00	52.80	11.07	51.80	15.30	13.60

RoHS COMPLIANT

UNITS = inch [mm]

DO NOT SCALE FROM DRAWING



THESE DRAWINGS AND SPECIFICATIONS ARE THE PROPERTY OF NorComp AND SHALL NOT BE REPRODUCED, COPIED OR USED AS THE BASIS FOR THE MANUFACTURE OR SALE OF APPARATUS WITHOUT WRITTEN PERMISSION.

DRAWN:  
P. JENKINS

DATE:  
08/18/1998

NorComp

SCALE:  
NTS

SHEET OF  
1 2

REV  
18

DWG NO.

170-YYY-17YLYY0

**TOLERANCE:**  
ALL DIMENSIONS ARE ±0.010

ALL CLINCH-NUTS ARE 4-40 INTERNAL THREADS

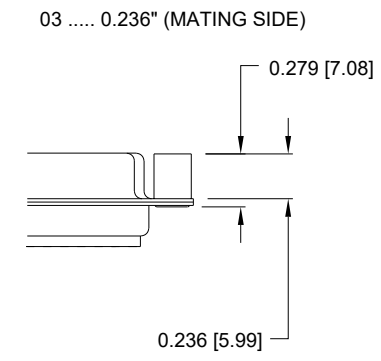
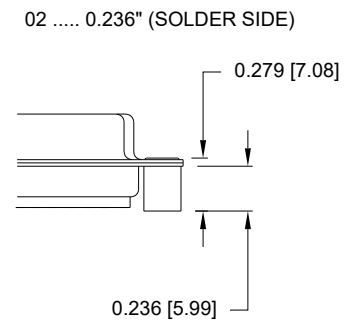
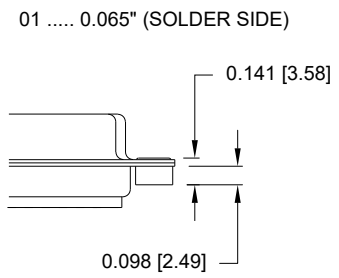

RoHS COMPLIANT

UNITS = inch [mm] DO NOT SCALE FROM DRAWING



THESE DRAWINGS AND SPECIFICATIONS ARE THE PROPERTY OF NorComp AND SHALL NOT BE REPRODUCED, COPIED OR USED AS THE BASIS FOR THE MANUFACTURE OR SALE OF APPARATUS WITHOUT WRITTEN PERMISSION.

DRAWN:  
**P. JENKINS**  
DATE:  
**08/18/1998**

**NorComp**

SCALE: NTS	SHEET 2	OF 2	REV 18
DWG NO.		<b>170-YYY-17YLYY0</b>	