

LOC		DIST		REVISIONS			
P	LTN	DESCRIPTION	DATE	OWN	APVD		
D		ECR-21-109837	25AUG2021	LZ	FL		

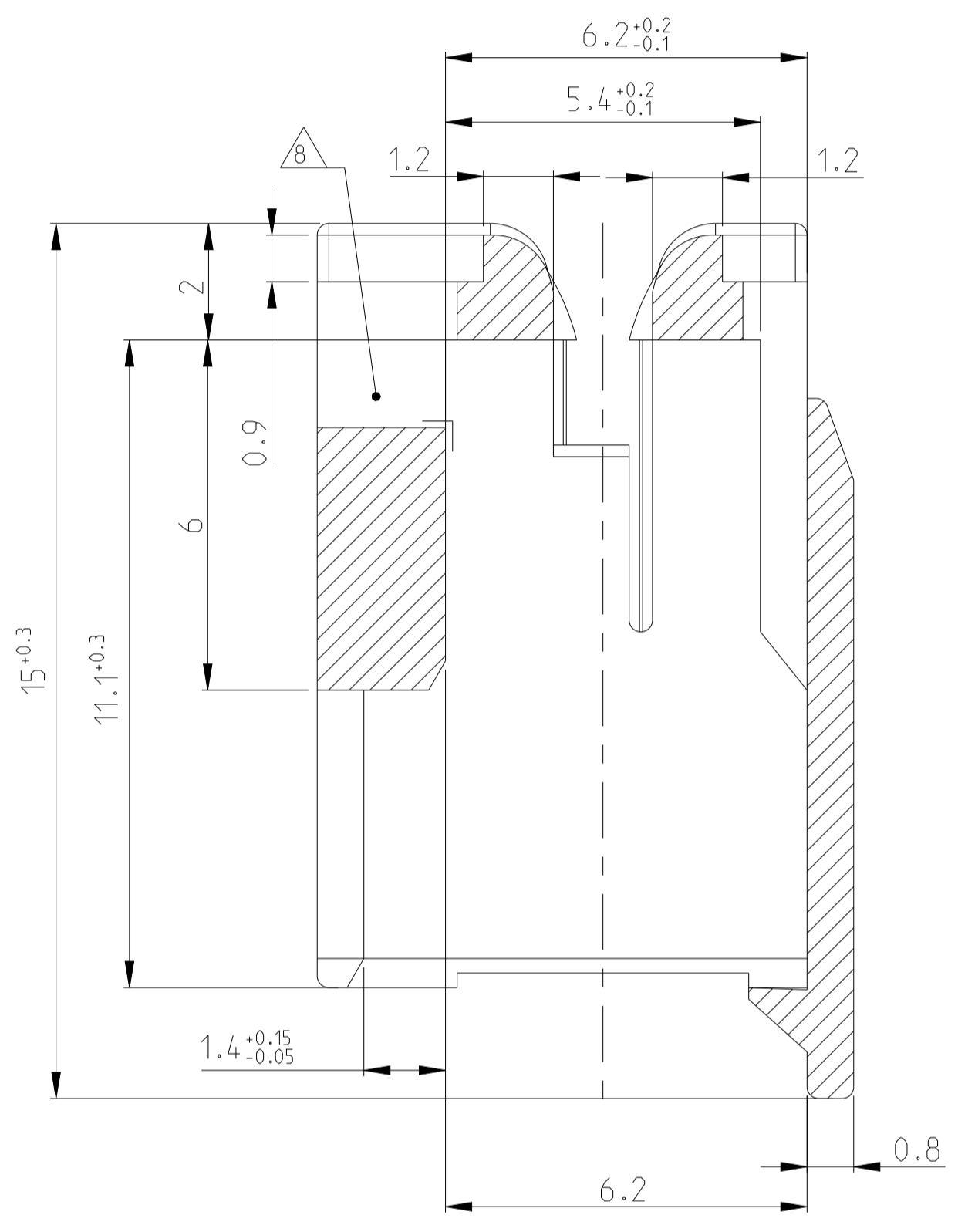

SECTION A-A

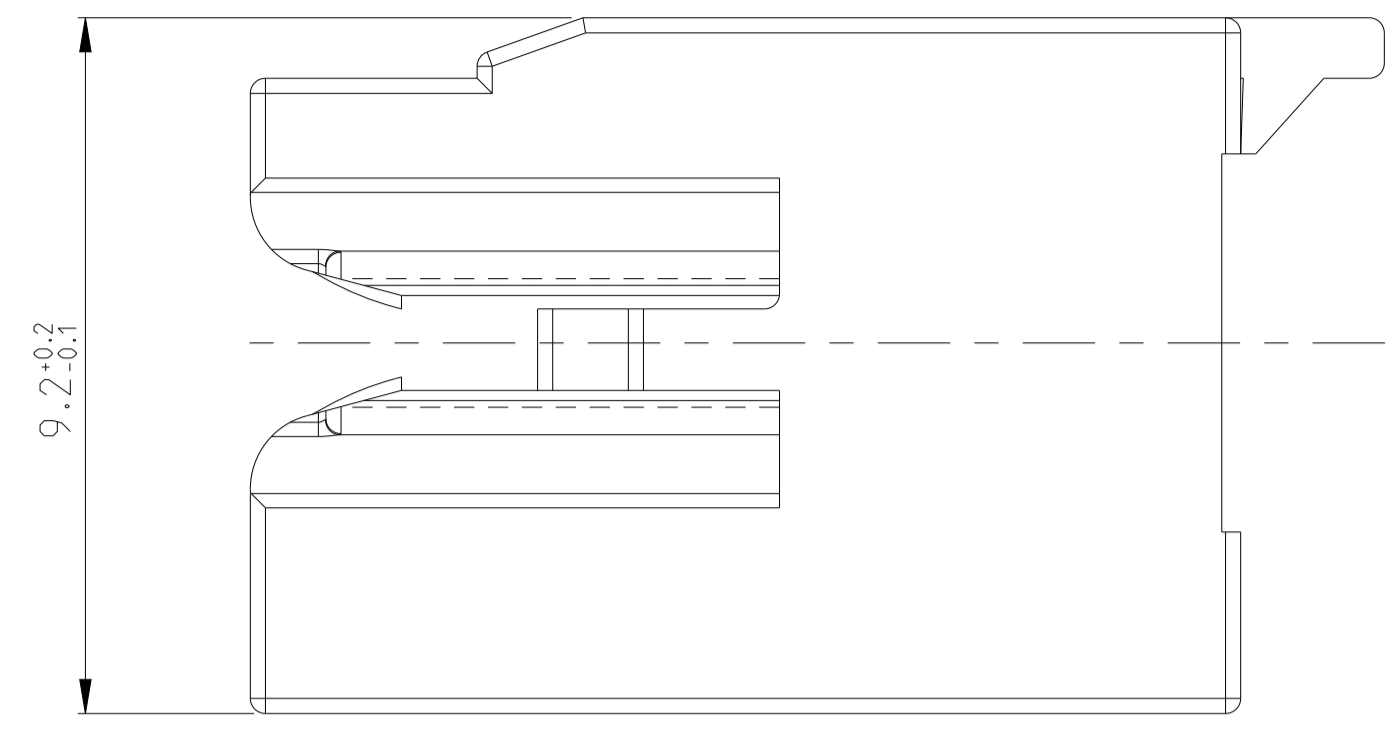
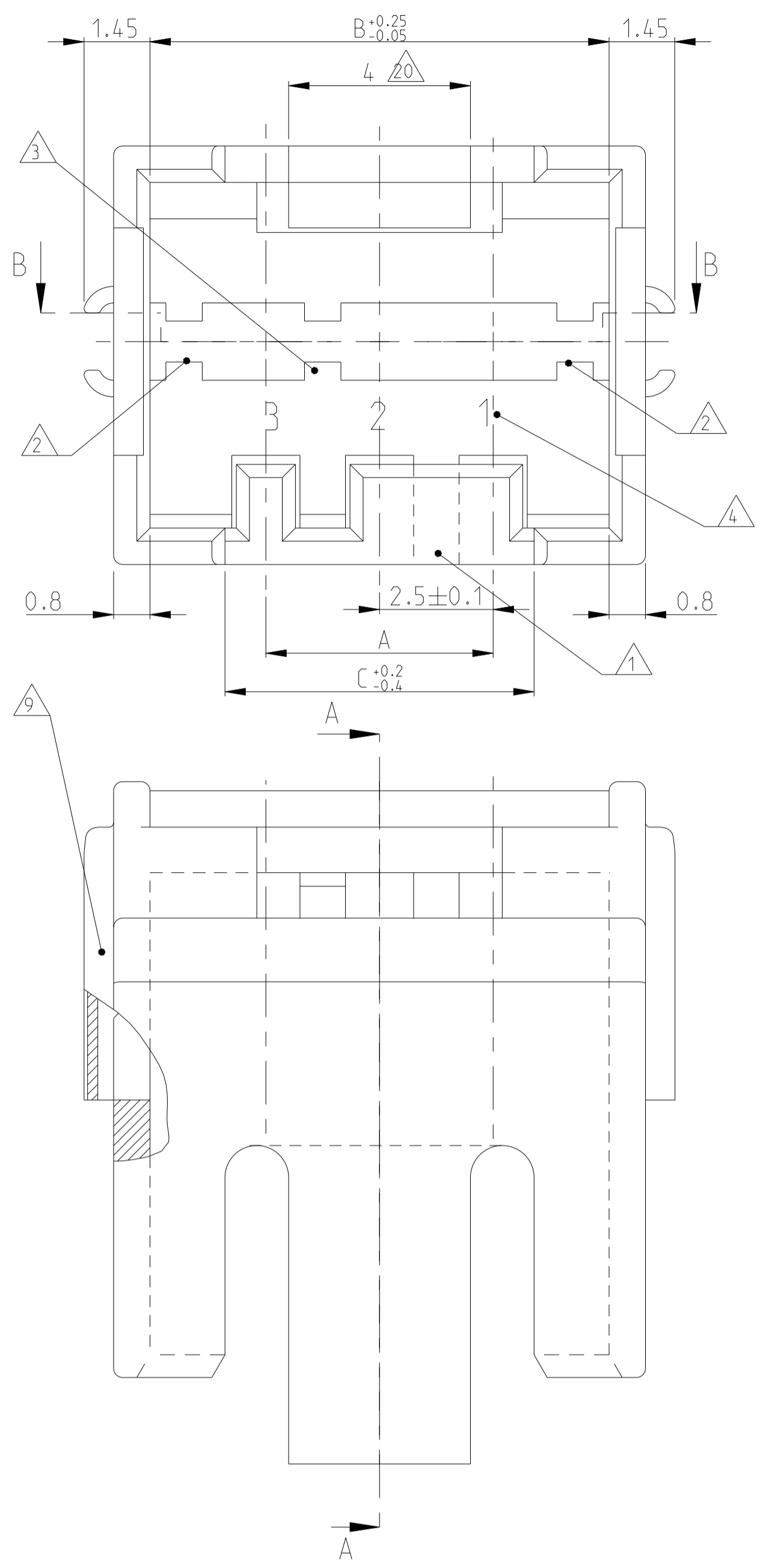
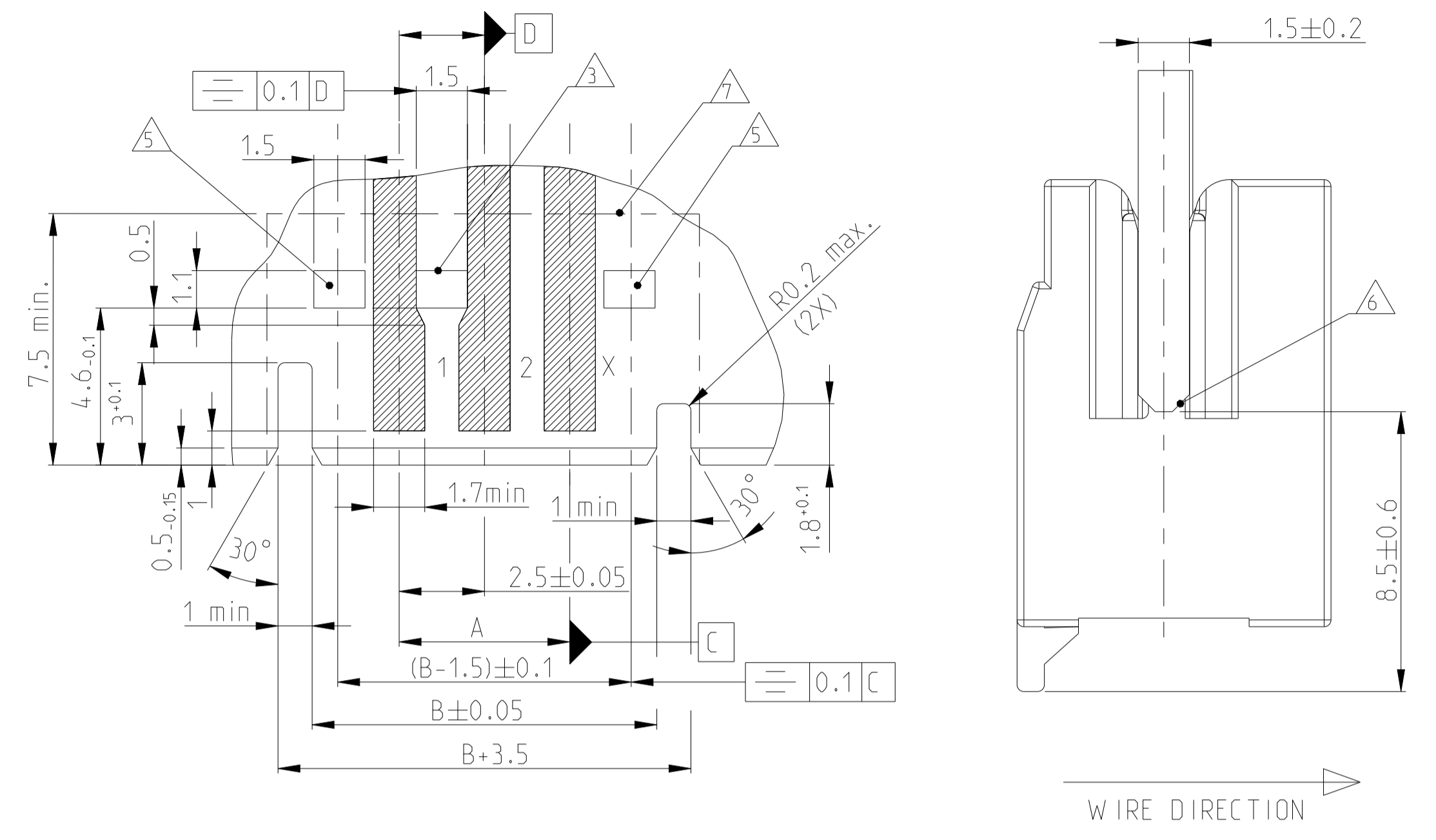

TOLERANCE NOT SPECIFIED ±0.1

- 1 KODIERUNG ZWISCHEN KAMMER 1 UND 2 DARGESTELLT (AUF ANFRAGE)
KEYING SHOWN BETWEEN CAVITY 1 AND 2 (ON REQUEST)
- 2 RASTHAKEN BEI ERSTER UND LETZTER KAMMER IMMER VORHANDEN
LOCKING CLIP ALWAYS ON FIRST AND LAST CAVITY
- 3 ZUSÄTZLICHE RASTHAKEN ZWISCHEN KAMMER-NR.SIEHE BLATT 2 VON 2
ADDITIONAL LOCKING CLIP BETWEEN CAVITY NO SEE SHEET 2 OF 2
- 4 KAMMERNUMMER
CAVITY NO
- 5 RASTFENSTER IMMER VORHANDEN
LOCKING WINDOW ALWAYS PRESENT
- 6 LEITERPLATTE VORZUGSWEISE ANGEFAST
PCB CHAMFERED PREFERABLE
- 7 PLATZBEDARF FOR RAHMEN
AREA FOR FRAME
- 8 PRÜFÖFFNUNGEN
INSPECTION HOLES
- 9 KLEMMFEDERN NICHT VOL AUSGESDRIPPTZTE KONTUR ZULÄSSIG
CLIPS SHAPE NOT FULLY MOLDED PERMISSIBLE

- 10 Passende Gegenstecker siehe PN 829 868/966 194
MATING PARTS SEE PN 829 868/966 194
- 12 WITH STROKE LINE DRAWN VERSIONS NOT YET AVAILABLE
- 13, 14, 15 SIEHE BLATT 2 VON 2
SEE SHEET 2 OF 2
- 16 Aubennuten eingeengt.
Varianten siehe Blatt 2)
GROOVES ON OUTSIDE NARROWED. VERSIONS SEE SHEET 2
- 17 GLOW WIRE TEST 750°C ACC.DIN EN 60695-2-11
WITHOUT FLAME
- 18 OBSOLETE
- 19 PRELIMINARY PART, NOT FOR PRODUCTION
- 20 HOOK DIMENSION, NOT THE DIMENSION FOR MIDDLE WALL
- 21 PARTS WITH LOW INSERTION FORCE

POS	DIM C	DIM B	DIM A	KEYING VERSIONS SEE SHEET 2 OF 2				REV	HOUSING PART NO
20	49.5	52.6	47.5	-				1-	964576-0
19	47	50.1	45.0	-				1- ¹⁸	964576-9
18	44.5	47.6	42.5	-				1-	964576-8
17	42	45.1	40.0	-				2- 1-	964576-7
16	39.5	42.6	37.5	-				1-	964576-6
15	37	40.1	35.0	-				2- ¹⁸ 1-	964576-5
14	34.5	37.6	32.5	-				1-	964576-4
13	32	35.1	30.0	-				1- ¹⁸	964576-3
12	29.5	32.6	27.5	-	6- ¹⁸	5-	4- ¹⁸	3- 2- 1- ¹⁸	964576-2
11	27	30.1	25.0	-				2- 1-	964576-1
10	24.5	27.6	22.5	-				3- ¹⁸ 2- 1- ¹⁸	964575-0
9	22	25.1	20.0	-				2- 1-	964575-9
9	22	25.1	20.0	-	9-			A	964575-9 ¹⁷
8	19.5	22.6	17.5	-	9-			A	964575-8 ¹⁷
8	19.5	22.6	17.5	-				2- 1- C	964575-8
7	17	20.1	15.0	-	9- ¹⁹			A	964575-7 ¹⁷
7	17	20.1	15.0	-				4- ¹⁸ 3- 2- 1- C	964575-7
6	14.5	17.6	12.5	-				3- 2- 1- C	964575-6
5	12	15.1	10.0	-	9- 8-	7-		A	964575-5 ¹⁷
5	12	15.1	10.0	-				4- 3- ¹⁸ 2- 1- C	964575-5
4	9.5	12.6	7.5	-	9- ¹⁹			C	964575-4 ¹⁷
4	9.5	12.6	7.5	-				4- ¹⁸ 3- 2- 1- C	964575-4
3	7	10.1	5.0	-	9-			2- ¹⁸ 1- C	964575-3
3	7	10.1	5.0	-				4- ²¹	964575-3 ¹⁷
3	7	10.1	5.0	-	8-	7-		3- A	964575-3 ¹⁷

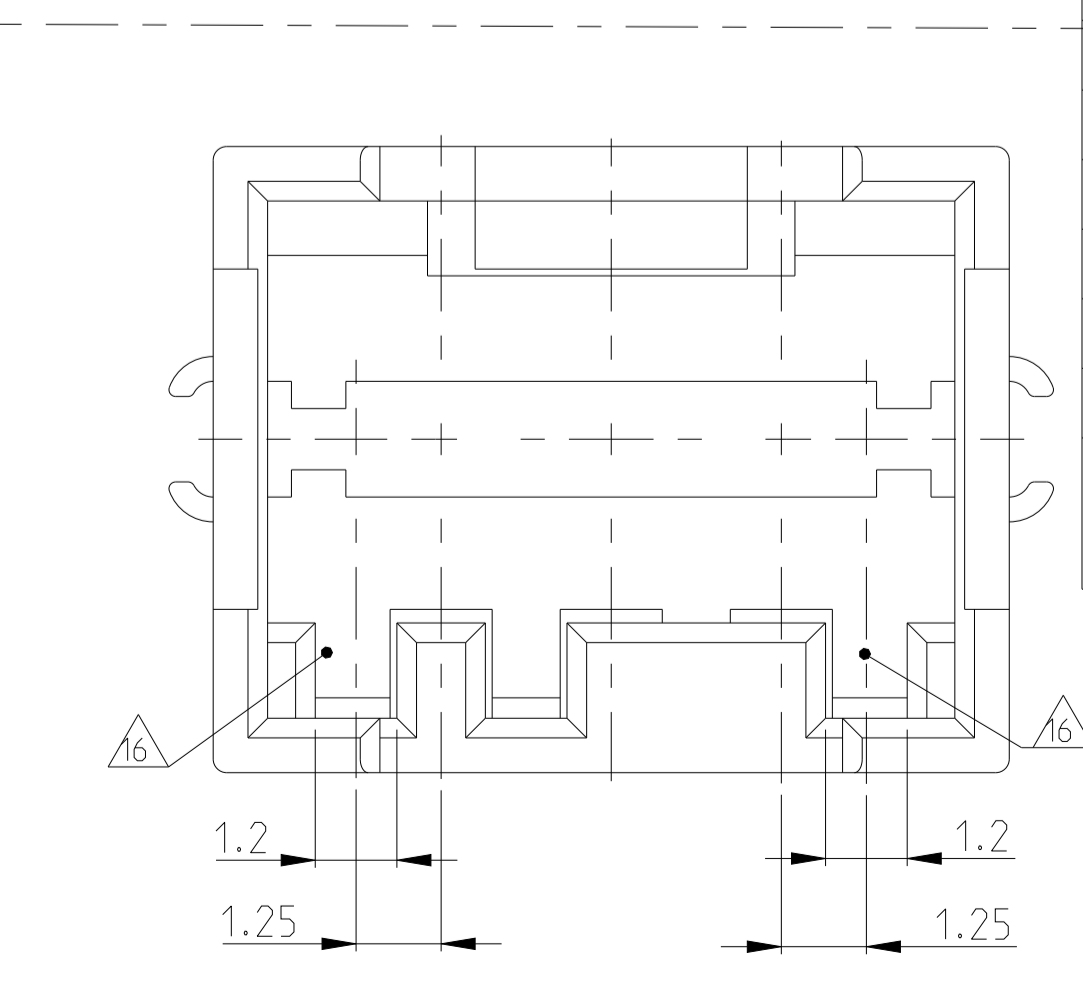

THIS DRAWING IS UNPUBLISHED. RELEASED FOR PUBLICATION. ALL RIGHTS RESERVED.

DIMENSIONS: mm

TOLERANCES UNLESS OTHERWISE SPECIFIED:

0 PLC	±
1 PLC	±0.2
2 PLC	±0.2
3 PLC	±
4 PLC	±
ANGLES	±
FINISH	±

MATERIAL: PA 6.6 25%GF UL94 V-0

FINISH: -

OWN: ATZMANN 06JULY2019

CHK: BORMUTH 06JULY2019

APVD: -

PRODUCT SPEC: -

APPLICATION SPEC: -

WEIGHT: -

CUSTOMER DRAWING

NAME: AMP DUOPLUG 2.5 SYSTEM PCB RAHMEN
AMP DUOPLUG 2.5 SYSTEM PCB FRAME (3-20 Posn)

SIZE: A1

CAGE CODE: -

DRAWING NO: 964575

RESTRICTED TO: -

SCALE: 8:1

SHEET: 1 OF 2

REV: D

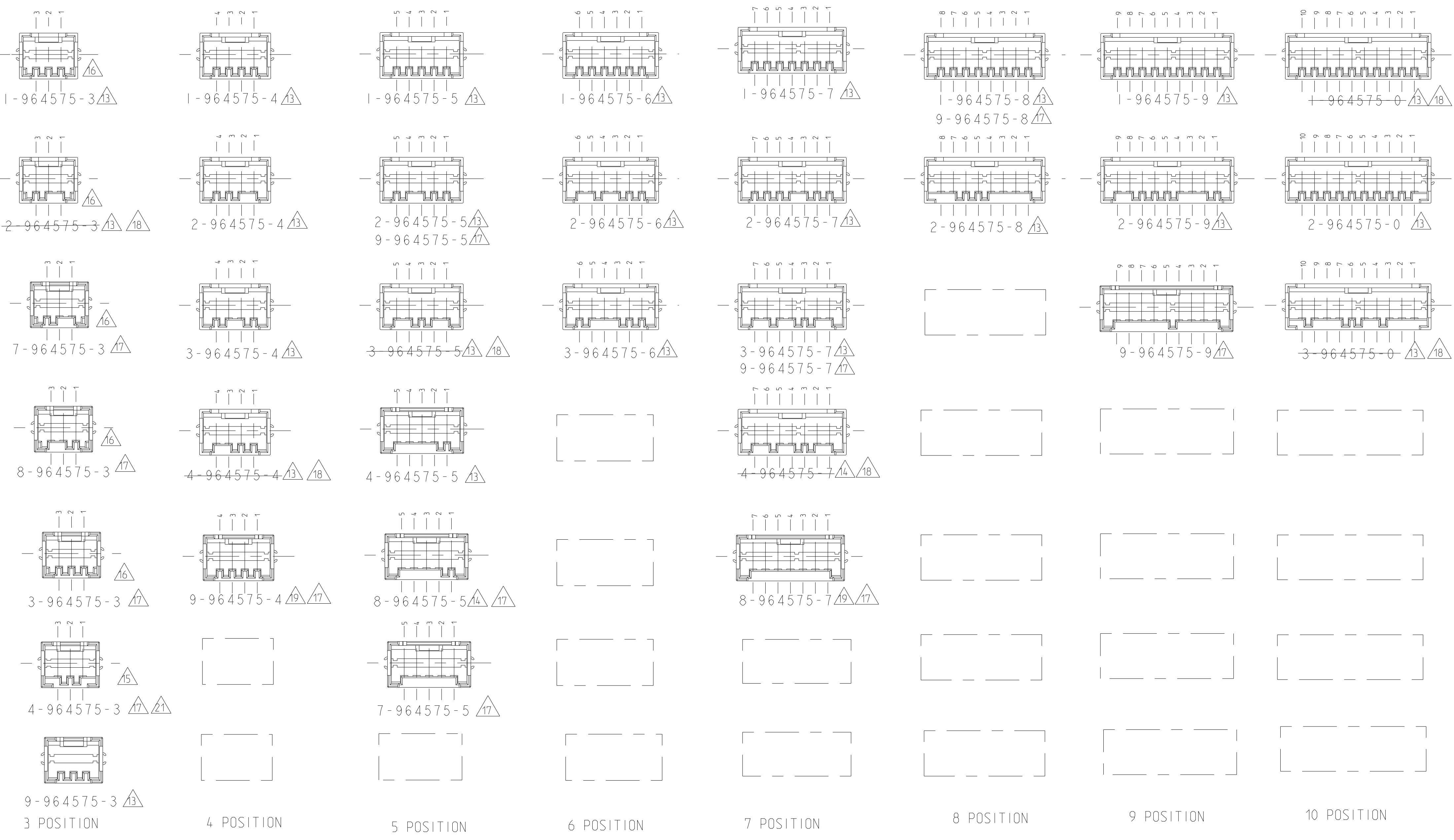

EXAMPLE:

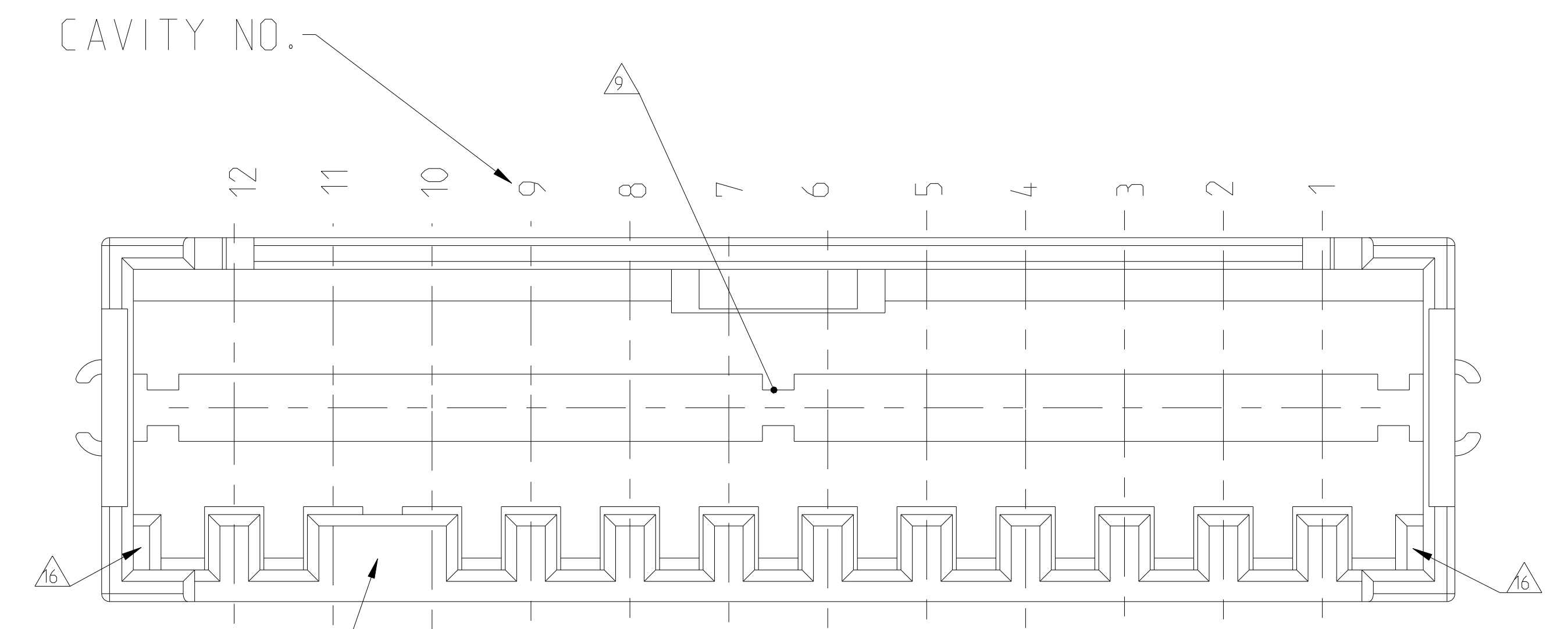

- △ COLOR: BLACK
- △ COLOR: NATURAL (REDBROWN)
- △ NATURAL (BEIGE)