

## High Voltage IGBT with Diode

(Electrically Isolated Back Surface)

### IXGR 35N120BD1

$$\begin{aligned} V_{CES} &= 1200 \text{ V} \\ I_{C25} &= 54 \text{ A} \\ V_{CE(sat)} &= 3.5 \text{ V} \\ t_{fi(typ)} &= 160 \text{ ns} \end{aligned}$$

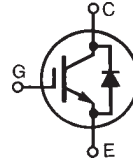

Symbol	Test Conditions	Maximum Ratings	
$V_{CES}$	$T_J = 25^\circ\text{C to } 150^\circ\text{C}$	1200	V
$V_{CGR}$	$T_J = 25^\circ\text{C to } 150^\circ\text{C}; R_{GE} = 1 \text{ M}\Omega$	1200	V
$V_{GES}$	Continuous	$\pm 20$	V
$V_{GEM}$	Transient	$\pm 30$	V
$I_{C25}$	$T_C = 25^\circ\text{C}$	54	A
$I_{C110}$	$T_C = 110^\circ\text{C}$	28	A
$I_{F110}$	$T_C = 110^\circ\text{C}$	8	A
$I_{CM}$	$T_C = 25^\circ\text{C}, 1 \text{ ms}$	200	A
<b>SSOA (RBSOA)</b>	$V_{GE} = 15 \text{ V}, T_J = 125^\circ\text{C}, R_G = 10 \Omega$ Clamped inductive load	$I_{CM} = 120$ @ $0.8 V_{CES}$	A
$P_C$	$T_C = 25^\circ\text{C}$	250	W
$T_J$		-55 ... +150	$^\circ\text{C}$
$T_{JM}$		150	$^\circ\text{C}$
$T_{stg}$		-55 ... +150	$^\circ\text{C}$
$V_{ISOL}$	50/60 Hz, RMS, $t = 1 \text{ min}$ $I_{SOL} = 1 \text{ mA}, t = 1 \text{ s}$	2500	V~
		3000	V~
$F_C$	Mounting force	22...130/5...29	N/lb
	Maximum lead temperature for soldering 1.6 mm (0.062 in.) from case for 10 s	300	$^\circ\text{C}$
<b>Weight</b>		6	g

#### ISOPLUS247 (IXGR)

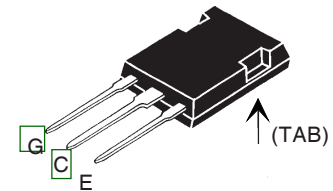

G = Gate  
E = Emitter  
C = Collector  
TAB = Electrically Isolated

#### Features

- Silicon chip on DCB substrate
  - High power dissipation
  - Isolated mounting surface
  - 2500V electrical isolation
- IGBT and anti-parallel FRED for resonant power supplies
  - Induction heating
  - Rice cookers
- MOS Gate turn-on
  - drive simplicity
- Fast Recovery Expitaxial Diode (FRED)
  - soft recovery with low  $I_{RM}$

#### Advantages

- Saves space (two devices in one package)
- Easy to mount
- Reduces assembly time and cost

Symbol	Test Conditions	Characteristic Values		
		min.	typ.	max.
$(T_J = 25^\circ\text{C}, \text{ unless otherwise specified})$				
$V_{GE(th)}$	$I_C = 250 \mu\text{A}, V_{CE} = V_{GE}$	2.5		5.0 V
$I_{CES}$	$V_{CE} = V_{CES}$ $V_{GE} = 0 \text{ V}$	$T = 25^\circ\text{C}$		50 $\mu\text{A}$
		$T = 125^\circ\text{C}$		250 $\mu\text{A}$
$I_{GES}$	$V_{CE} = 0 \text{ V}, V_{GE} = \pm 20 \text{ V}$			$\pm 100 \text{ nA}$
$V_{CE(sat)}$	$I_C = 35 \text{ A}, V_{GE} = 15 \text{ V}$ Note 2		2.8	3.5 V

Symbol	Test Conditions	Characteristic Values ( $T_J = 25^\circ\text{C}$ , unless otherwise specified)		
		min.	typ.	max.
$g_{fs}$	$I_C = 35\text{A}; V_{CE} = 10\text{V}$ , Note 2.	28	38	S
$C_{ies}$			2300	pF
$C_{oes}$	$V_{CE} = 25\text{V}, V_{GE} = 0\text{V}, f = 1\text{MHz}$		190	pF
$C_{res}$			80	pF
$Q_g$			140	nC
$Q_{ge}$	$I_C = 40\text{A}, V_{GE} = 15\text{V}, V_{CE} = 0.5 V_{CES}$		20	nC
$Q_{gc}$			50	nC
$t_{d(on)}$	<b>Inductive load, <math>T_J = 25^\circ\text{C}</math></b>		40	ns
$t_{ri}$	$I_C = 35\text{A}; V_{GE} = 15\text{V}$		50	ns
$E_{on}$	$V_{CE} = 0.8 V_{CES}; R_G = R_{off} = 3\ \Omega$		0.9	mJ
$t_{d(off)}$	Note 1.		270	500 ns
$t_{fi}$			160	300 ns
$E_{off}$			3.8	7.0 mJ
$t_{d(on)}$	<b>Inductive load, <math>T_J = 125^\circ\text{C}</math></b>		45	ns
$t_{ri}$	$I_C = 35\text{A}; V_{GE} = 15\text{V}$		60	ns
$E_{on}$	$V_{CE} = 0.8 V_{CES}; R_G = R_{off} = 3\ \Omega$		1.9	mJ
$t_{d(off)}$	Note 1		380	ns
$t_{fi}$			400	ns
$E_{off}$			8.0	mJ
$R_{thJC}$				0.5 K/W
$R_{thCK}$			0.25	K/W

### ISOPLUS247 Outline

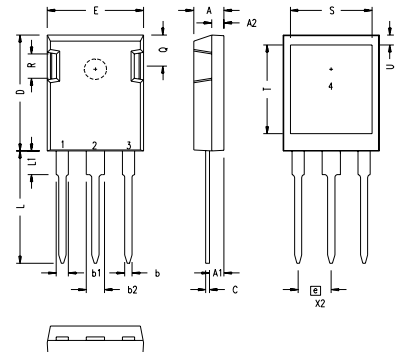

SYM	INCHES		MILLIMETERS	
	MIN	MAX	MIN	MAX
A	.190	.205	4.83	5.21
A1	.090	.100	2.29	2.54
A2	.075	.085	1.91	2.16
b	.045	.055	1.14	1.40
b1	.075	.084	1.91	2.13
b2	.115	.123	2.92	3.12
C	.024	.031	0.61	0.80
D	.819	.840	20.80	21.34
E	.620	.635	15.75	16.13
e	.215 BSC		5.45 BSC	
L	.780	.800	19.81	20.32
L1	.150	.170	3.81	4.32
Q	.220	.244	5.59	6.20
R	.170	.190	4.32	4.83
S	.520	.540	13.21	13.72
T	.620	.640	15.75	16.26
U	.065	.080	1.65	2.03

- 1 - GATE
- 2 - DRAIN (COLLECTOR)
- 3 - SOURCE (EMITTER)
- 4 - NO CONNECTION

NOTE: This drawing will meet all dimensions requirement of JEDEC outline TO-247AD except screw hole.

Symbol	Test Conditions	Characteristic Values ( $T_J = 25^\circ\text{C}$ , unless otherwise specified)		
		min.	typ.	max.
$V_F$	$I_F = 10\text{A}, V_{GE} = 0\text{V}$ $I_F = 10\text{A}, V_{GE} = 0\text{V}, T_J = 125^\circ\text{C}$			3.3 V 2.2 V
$I_{RM}$	$I_F = 10\text{A}; -di_F/dt = 100\text{A}/\mu\text{s}, V_R = 100\text{V}$		4.0	A
$t_{rr}$	$V_{GE} = 0\text{V}; T_J = 125^\circ\text{C}$		190	ns
$t_{rr}$	$I_F = 1\text{A}; -di_F/dt = 100\text{A}/\mu\text{s}; V_R = 30\text{V}, V_{GE} = 0\text{V}$		40	ns
$R_{thJC}$				2.5 K/W

- Notes:
- Switching times may increase for  $V_{CE}(\text{Clamp}) > 0.8 \cdot V_{CES}$ , higher  $T_J$  or increased  $R_G$ .
  - Pulse test,  $t \leq 300\ \mu\text{s}$ , duty cycle  $d \leq 2\%$ .

IXYS reserves the right to change limits, test conditions, and dimensions.

IXYS MOSFETs and IGBTs are covered by one or more of the following U.S. patents:	4,835,592	4,931,844	5,049,961	5,237,481	6,162,665	6,404,065B1	6,683,344	6,727,585
	4,850,072	5,017,508	5,063,307	5,381,025	6,259,123B1	6,534,343	6,710,405B2	
	4,881,106	5,034,796	5,187,117	5,486,715	6,306,728 B1	6,583,505	6,710,463	