



QT-Brightek Optocoupler Series

1 Mbit/s High Speed Phototransistor Optocoupler

Part No.: 6N135, 6N136, QT4502, QT4503

Product: 6N135_6N136_QT4502_QT4503	Date: February 12, 2018	Page 1 of 20
	Version# 1.0	



Table of Contents:

Introduction3
Absolute Maximum Rating6
Electrical Characteristic ($T_A=25\text{ }^\circ\text{C}$).....7
Characteristic Curves.....10
Test Circuits12
Solder Profile & Footprint14
Packing & Labeling17
Device Marking18
Ordering Information19
Revision History20
Disclaimer20

Introduction

Feature:

- High Speed phototransistor 1Mbit/s
- High Isolation voltage between input and output (Viso = 5000V rms)
- Creepage distance > 7.4mm
- Available in Tube or Tape and reel
- Available with standard DIP-8, gullwing lead bend, SMD lead bend, and SMD low profile options.

Schematic:

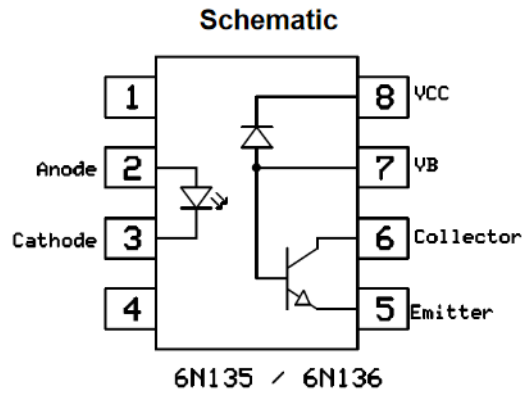

Pin 7 not connected for QT4502 and QT4503

Certification & Compliance:

- Pb free and RoHS Compliant
- UL recognized (File #E338132)
- cUL recognized (File #E338132)
- VDE (File #40030457)



Dimension: (Dot location indicates pin 1) 8-Pin Dip (standard):

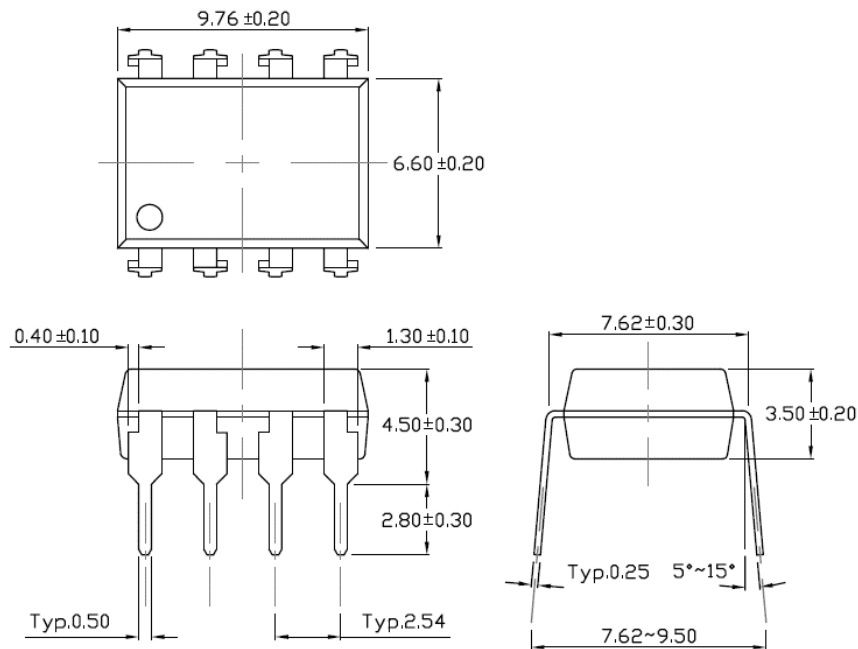

Gullwing (400mil) lead bend (Option M):

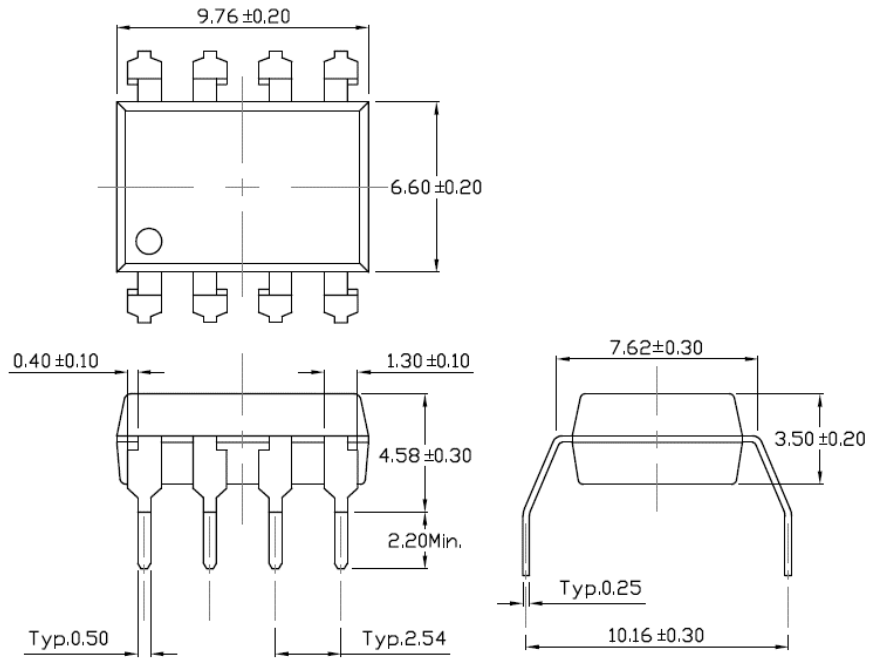

SMD lead bend (Option S):

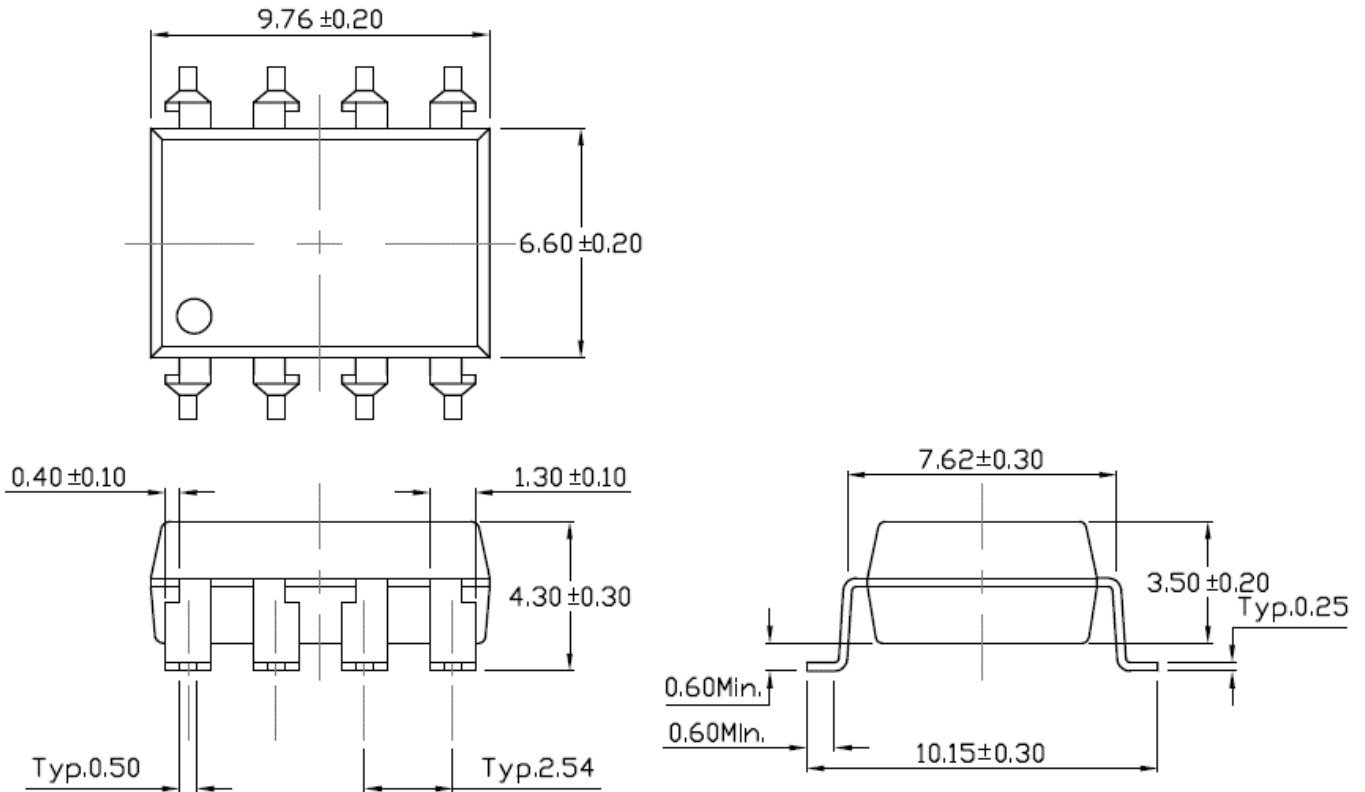

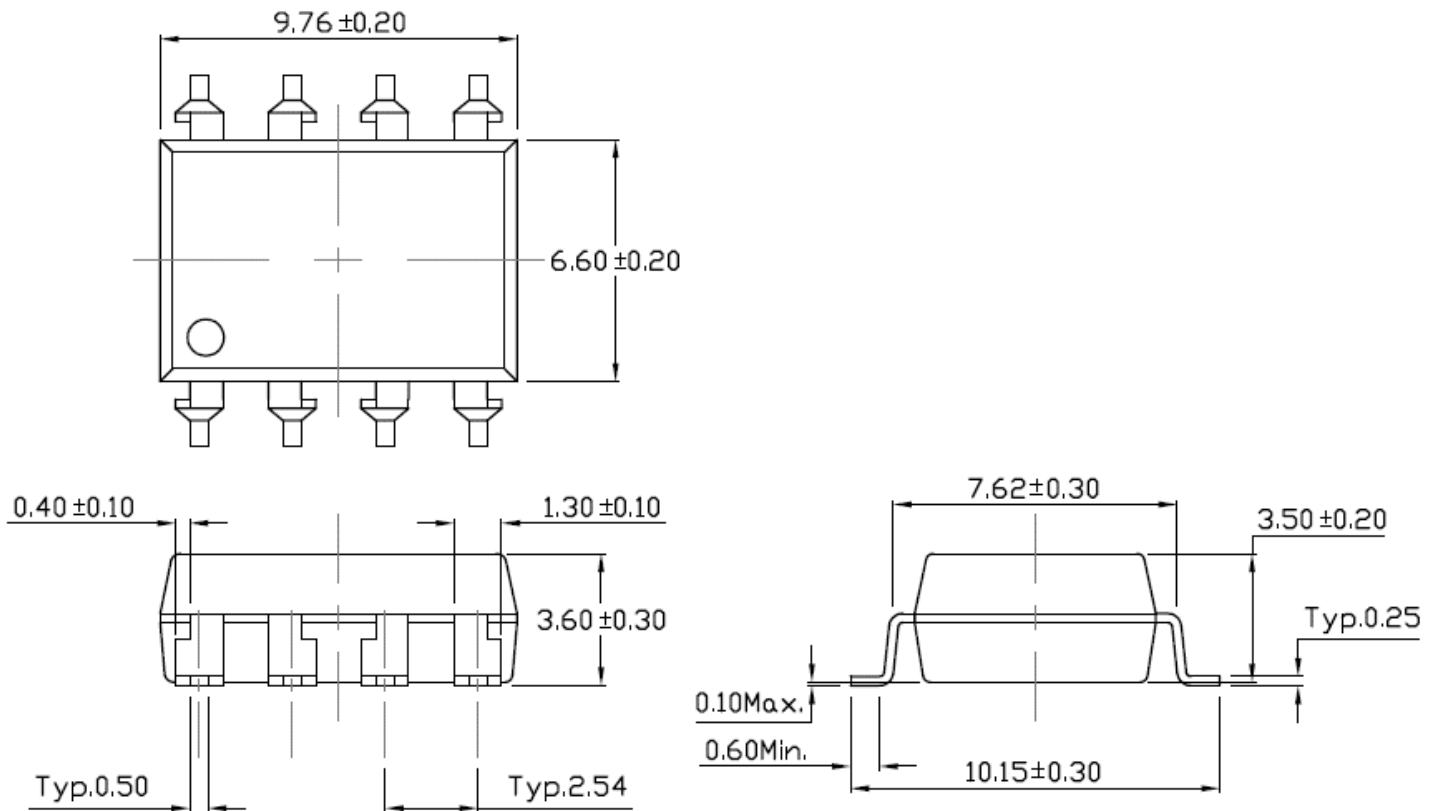
SMD (Low Profile) bend (Option SL):

All Dimensions are in mm

Absolute Maximum Rating

Symbol	Parameter	Rating	Units
V_{ISO}	Isolation Voltage*	5000	V_{RMS}
T_{STG}	Storage Temperature	-55 ~ +125	$^{\circ}C$
T_{OPR}	Operating Temperature	-55 ~ +100	$^{\circ}C$
T_{SOL}	Lead Solder Temperature	260 for 10 sec	$^{\circ}C$

EMITTER

I_F	Forward Current	25	mA
I_{FP}	Peak Forward Current (50% duty, 1ms P.W)	50	mA
$I_{F(TRANS)}$	Peak transient Current ($\leq 1\mu s$, 300pps)	1	A
V_R	Reverse Voltage	5	V
P_D	Power Dissipation	40	mW
	Power Dissipation Derated above 100 $^{\circ}C$	-	mW/ $^{\circ}C$

DETECTOR

P_D	Power Dissipation	100	mW
V_{EBR}	Emitter-Base reverse voltage	5	V
I_B	Base current	5	mA
$I_{O(AVG)}$	Average Output current	8	mA
$I_{O(PEAK)}$	Peak Output current	16	mA
V_O	Output voltage	-0.5 to 20	V
V_{CC}	Supply voltage	-0.5 to 30	V

*AC for 1 minute, RH =40~60%

Electrical Characteristic ($T_A=25^\circ\text{C}$)

($T_A=0$ to 70°C unless specified otherwise)

Emitter

Symbol	Characteristics	Device	Test Condition	Range			Unit
				Min	Typ	Max	
V_F	Forward Voltage	-	$I_F = 16\text{mA}$	-	1.45	1.6	V
V_R	Reverse Voltage		$I_R = 10\mu\text{A}$	5	-	-	V
$\Delta V_F / \Delta T_A$	Temperature coefficient of forward voltage		$I_F = 16\text{mA}$	-	-1.8	-	mV/ $^\circ\text{C}$

Detector

Symbol	Characteristic	Device	Test Condition	Range			Unit
				Min	Typ	Max	
I_{OH}	Logic High Output Current	-	$I_F=0\text{mA}, V_O=V_{CC}=5.5\text{V}, T_A=25^\circ\text{C}$	-	0.001	0.5	μA
			$I_F=0\text{mA}, V_O=V_{CC}=15\text{V}, T_A=25^\circ\text{C}$	-	0.01	1	
			$I_F=0\text{mA}, V_O=V_{CC}=15\text{V}$	-	-	50	
I_{CCL}	Logic Low Supply Current	-	$I_F=16\text{mA}, V_O=\text{Open}, V_{CC}=15\text{V}$	-	140	200	μA
I_{CCH}	Logic High Supply Current	-	$I_F=0\text{mA}, V_O=\text{Open}, V_{CC}=15\text{V}, T_A=25^\circ\text{C}$	-	0.01	1	μA
			$I_F=0\text{mA}, V_O=\text{Open}, V_{CC}=15\text{V}$	-	-	2	

Transfer Characteristics

Symbol	Characteristic	Device	Test Condition	Range			Unit
				Min	Typ	Max	
CTR	Current Transfer Ratio	6N135	$I_F=16\text{mA}, V_O=0.4\text{V}, V_{CC}=4.5\text{V}, T_A=25^\circ\text{C}$	7	-	50	%
		6N136 QT4502 QT4503		19	-	50	
		6N135	$I_F=16\text{mA}, V_O=0.5\text{V}, V_{CC}=4.5\text{V}$	5	-	-	
		6N136 QT4502 QT4503		15	-	-	
V_{OL}	Logic Low Output Voltage	6N135	$I_F=16\text{mA}, I_O=1.1\text{mA}, V_{CC}=4.5\text{V}, T_A=25^\circ\text{C}$	-	0.18	0.4	V
		6N136 QT4502 QT4503	$I_F=16\text{mA}, I_O=3\text{mA}, V_{CC}=4.5\text{V}, T_A=25^\circ\text{C}$	-	0.18	0.4	
		6N135	$I_F=16\text{mA}, I_O=0.8\text{mA}, V_{CC}=4.5\text{V}$	-	-	0.5	
		6N136 QT4502 QT4503	$I_F=16\text{mA}, I_O=2.4\text{mA}, V_{CC}=4.5\text{V}$	-	-	0.5	

Switching Characteristics (TA=25°C, VCC=5V)

Symbol	Characteristic	Device	Test Condition	Range			Unit
				Min	Typ	Max	
T _{PHL}	Propagation Delay Time Logic High to Logic Low	6N135	R _L =4.1KΩ, T _A =25°C	-	0.35	1.5	μs
			R _L =4.1KΩ	-	-	2.0	
		6N136 QT4502 QT4503	R _L =1.9KΩ, T _A =25°C	-	0.35	0.8	
			R _L =1.9KΩ	-	-	1.0	
T _{PLH}	Propagation Delay Time Logic Low to Logic High	6N135	R _L =4.1KΩ, T _A =25°C	-	0.35	1.5	μs
			R _L =4.1KΩ	-	-	2.0	
		6N136 QT4502 QT4503	R _L =1.9KΩ, T _A =25°C	-	0.35	0.8	
			R _L =1.9KΩ	-	-	1.0	
CM _H	Common Mode Transient Immunity at Logic High	6N135	I _F = 0mA, V _{CM} =10Vp-p, R _L =4.1kΩ, T _A =25°C	1000	-	-	V/μs
		6N136 QT4502	I _F = 0mA, V _{CM} =10Vp-p, R _L =1.9kΩ, T _A =25°C	1000	-	-	
		QT4503	I _F = 0mA, V _{CM} =1500Vp-p, R _L =1.9kΩ, T _A =25°C	15000	20000	-	
CM _L	Common Mode Transient Immunity at Logic Low	6N135	I _F = 16mA, V _{CM} =10Vp-p, R _L =4.1kΩ, T _A =25°C	1000	-	-	V/μs
		6N136 QT4502	I _F = 16mA, V _{CM} =10Vp-p, R _L =1.9kΩ, T _A =25°C	1000	-	-	
		QT4503	I _F = 16mA, V _{CM} =1500Vp-p, R _L =1.9kΩ, T _A =25°C	15000	20000	-	

Characteristic Curves

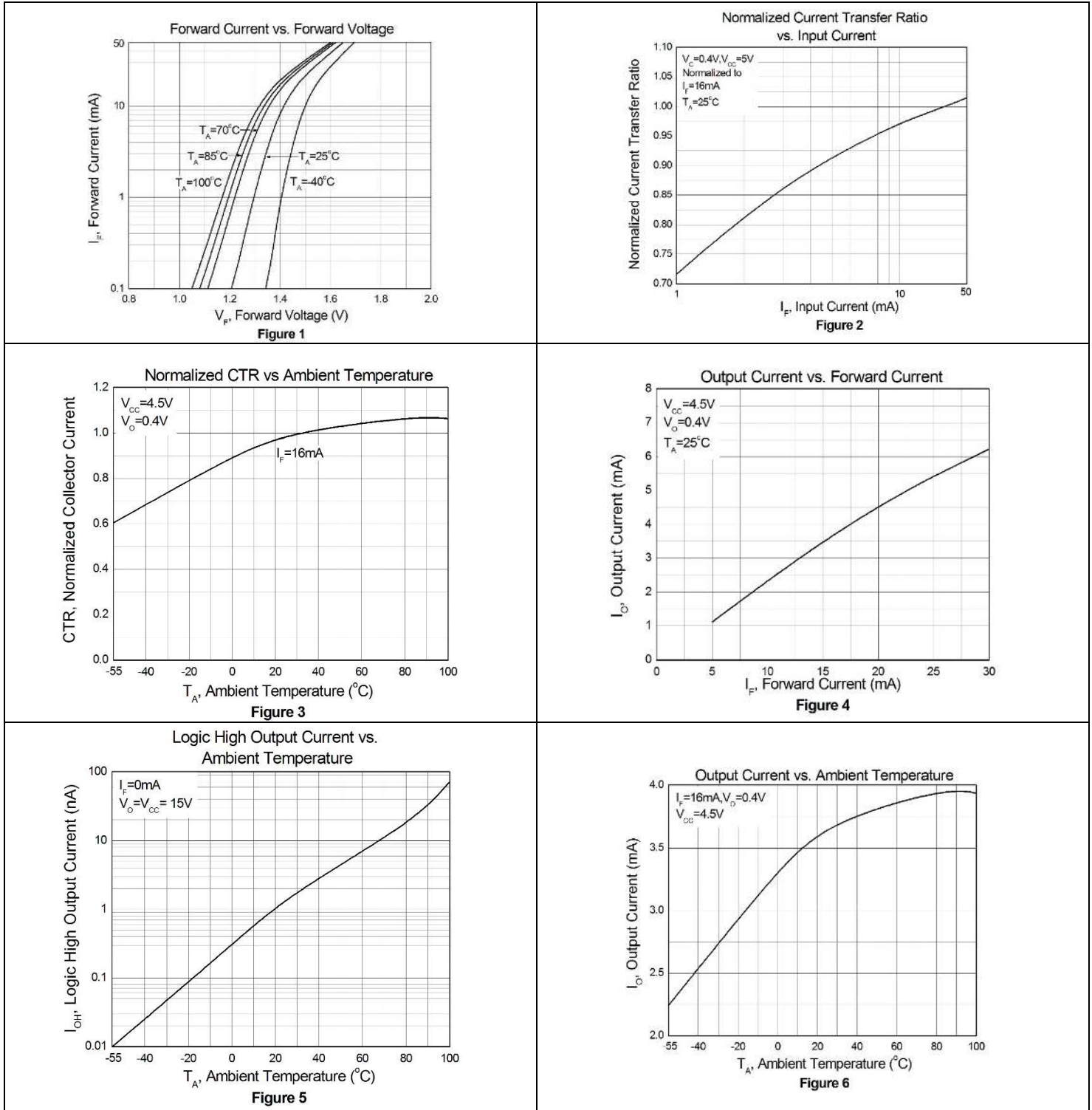

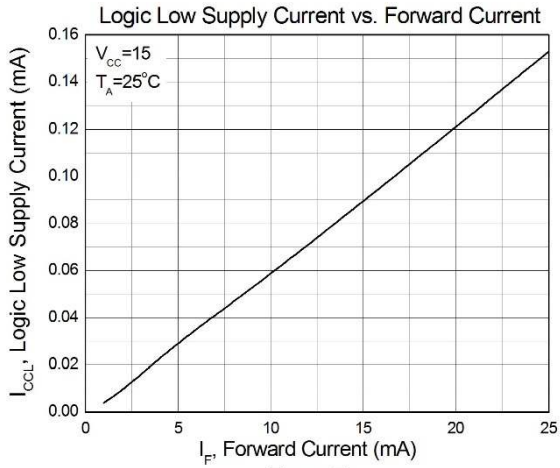

Figure 7

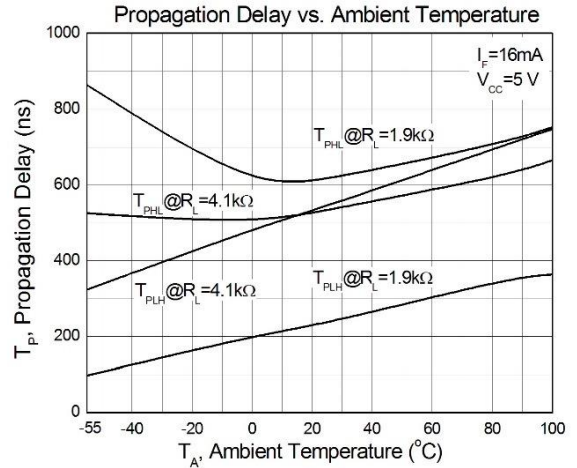

Figure 8

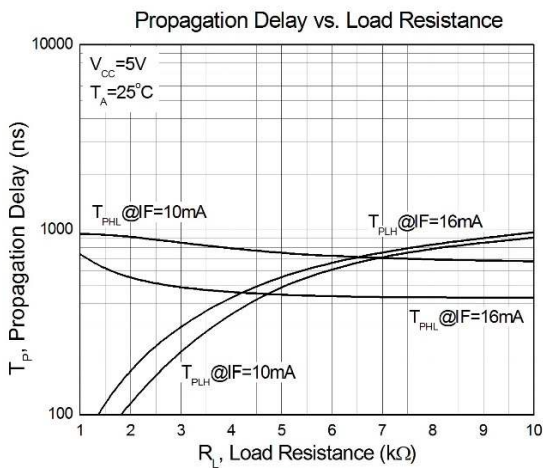
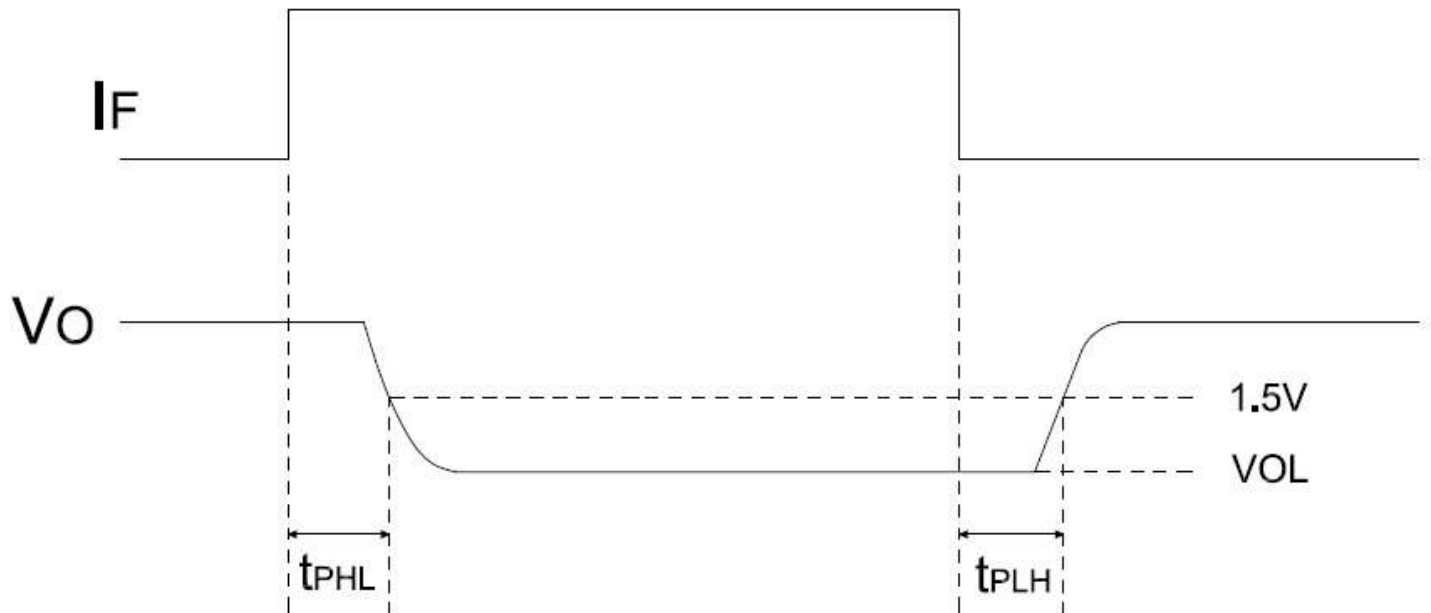
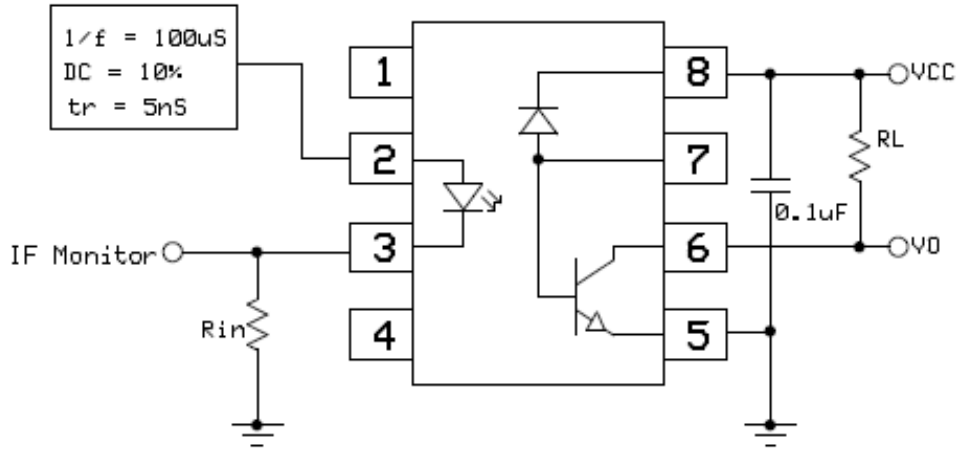
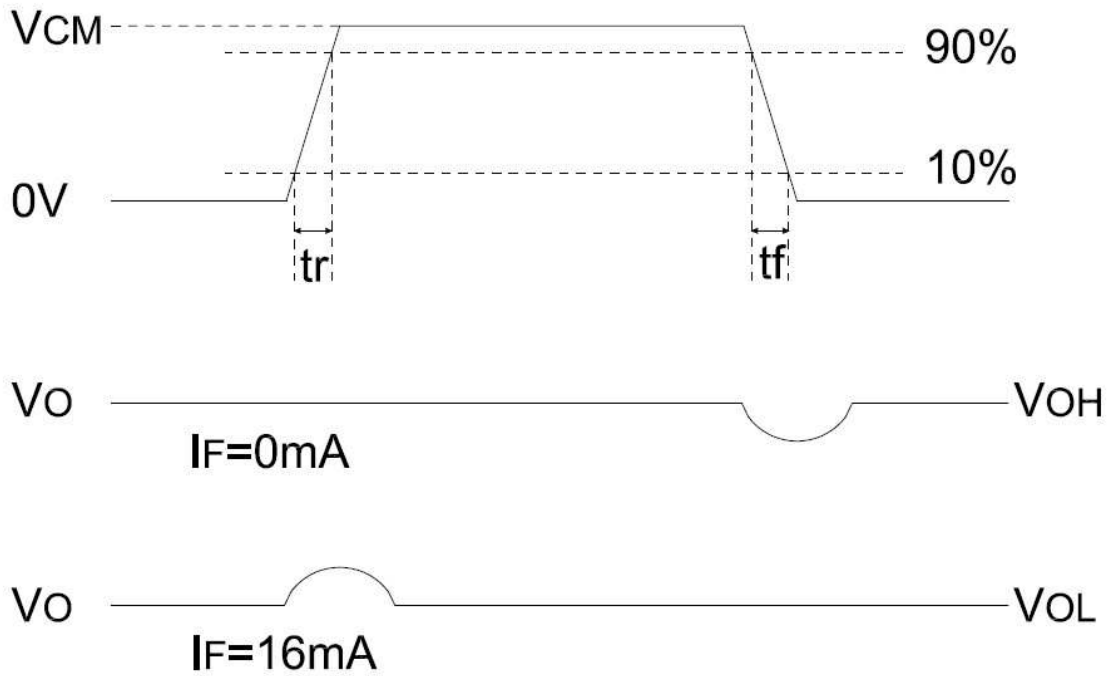
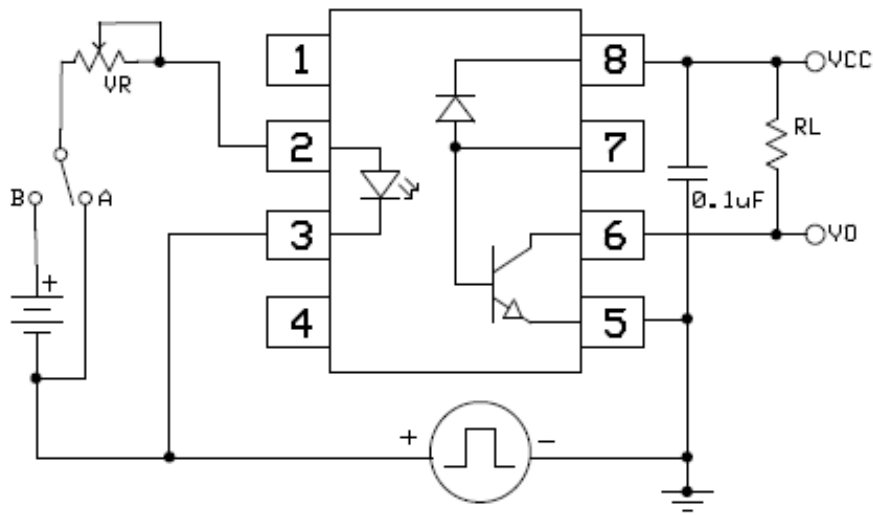

Figure 9

Test Circuits



Switching Time Test Circuit



CMR Test Circuit

Solder Profile & Footprint

Wave soldering

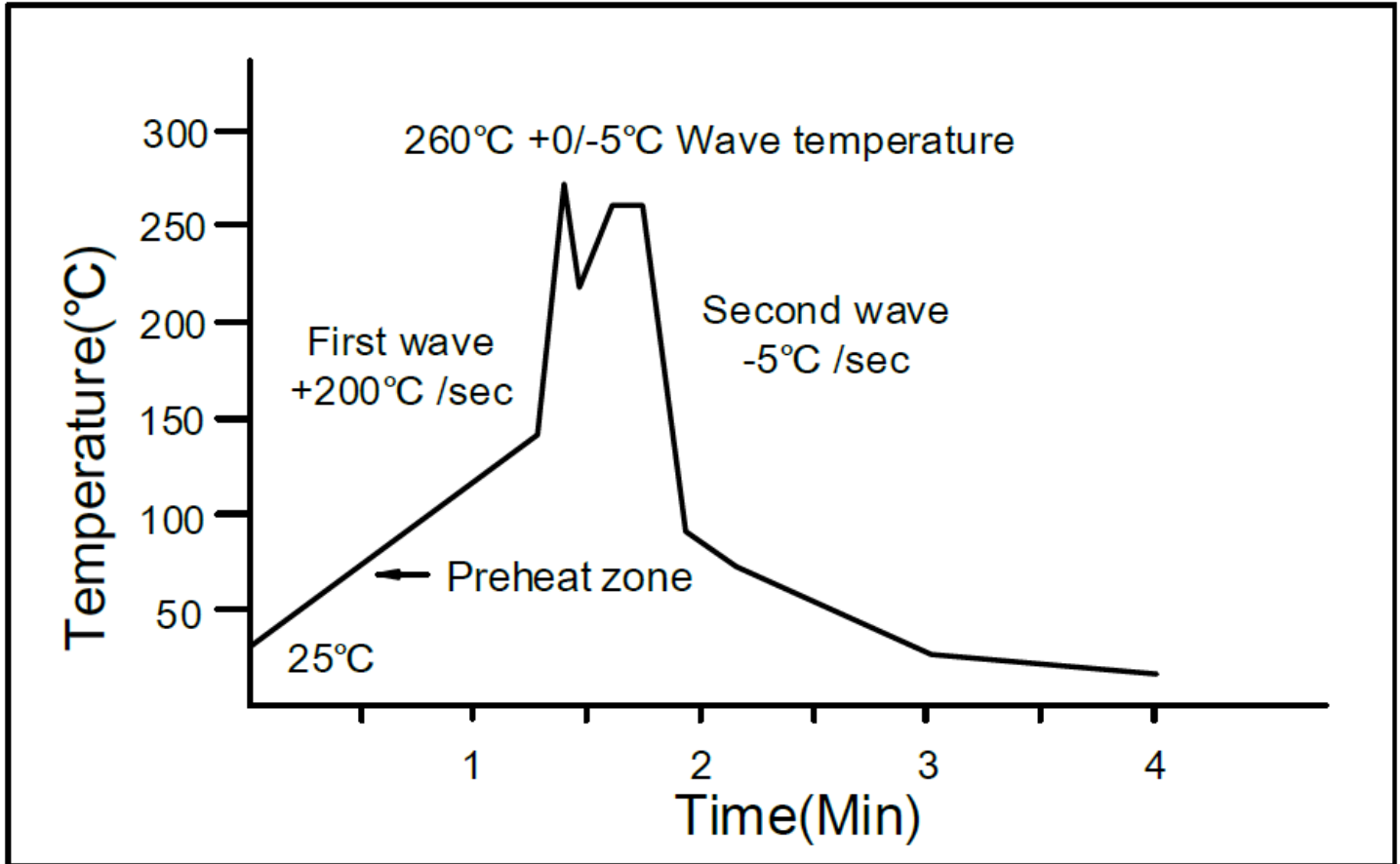

Temperature: 260 +0/-5 °C

Time: 10 Sec

Preheat temperature: 25 to 140 °C

Preheat time: 30 to 80 sec.

Reflow Soldering

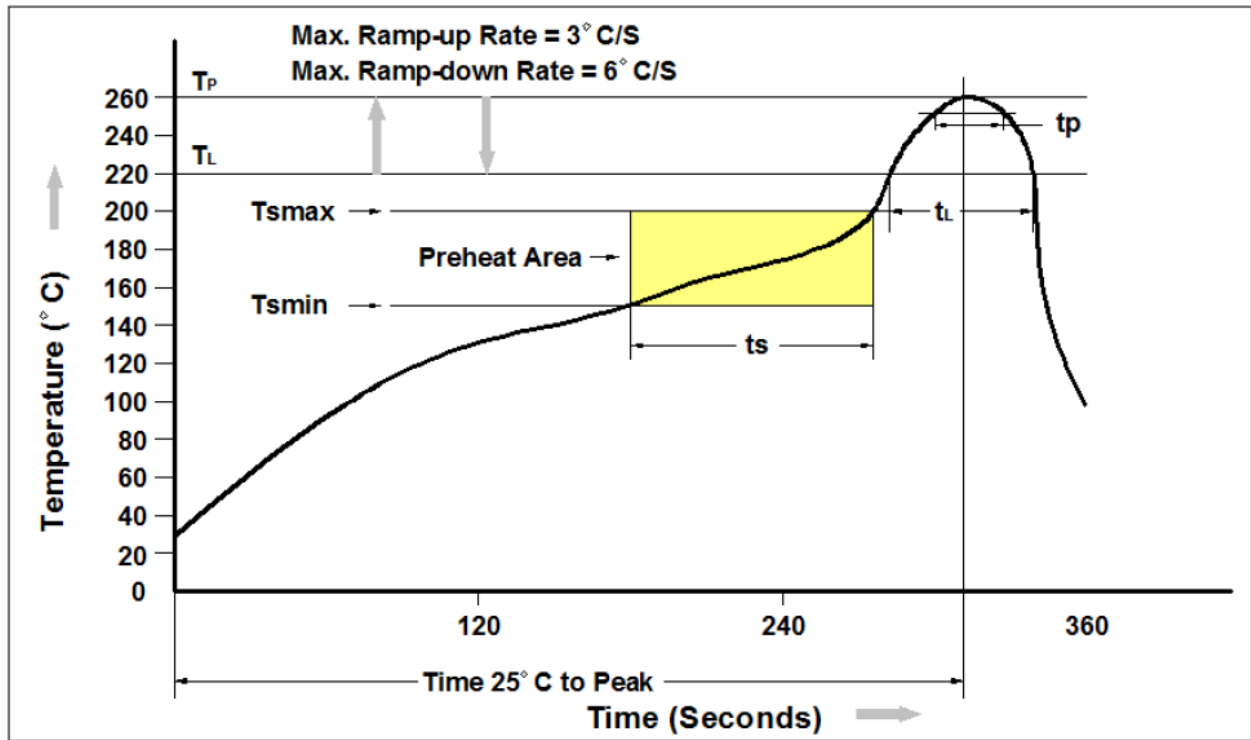

Profile Feature	Pb-Free Assembly Profile
Temperature Min. (T_{smin})	150°C
Temperature Max. (T_{smax})	200°C
Time (t_s) from (T_{smin} to T_{smax})	60-120 seconds
Ramp-up Rate (t_L to t_P)	3°C/second max.
Liquidous Temperature (T_L)	217°C
Time (t_L) Maintained Above (T_L)	60 – 150 seconds
Peak Body Package Temperature	260°C +0°C / -5°C
Time (t_P) within 5°C of 260°C	30 seconds
Ramp-down Rate (T_P to T_L)	6°C/second max
Time 25°C to Peak Temperature	8 minutes max.

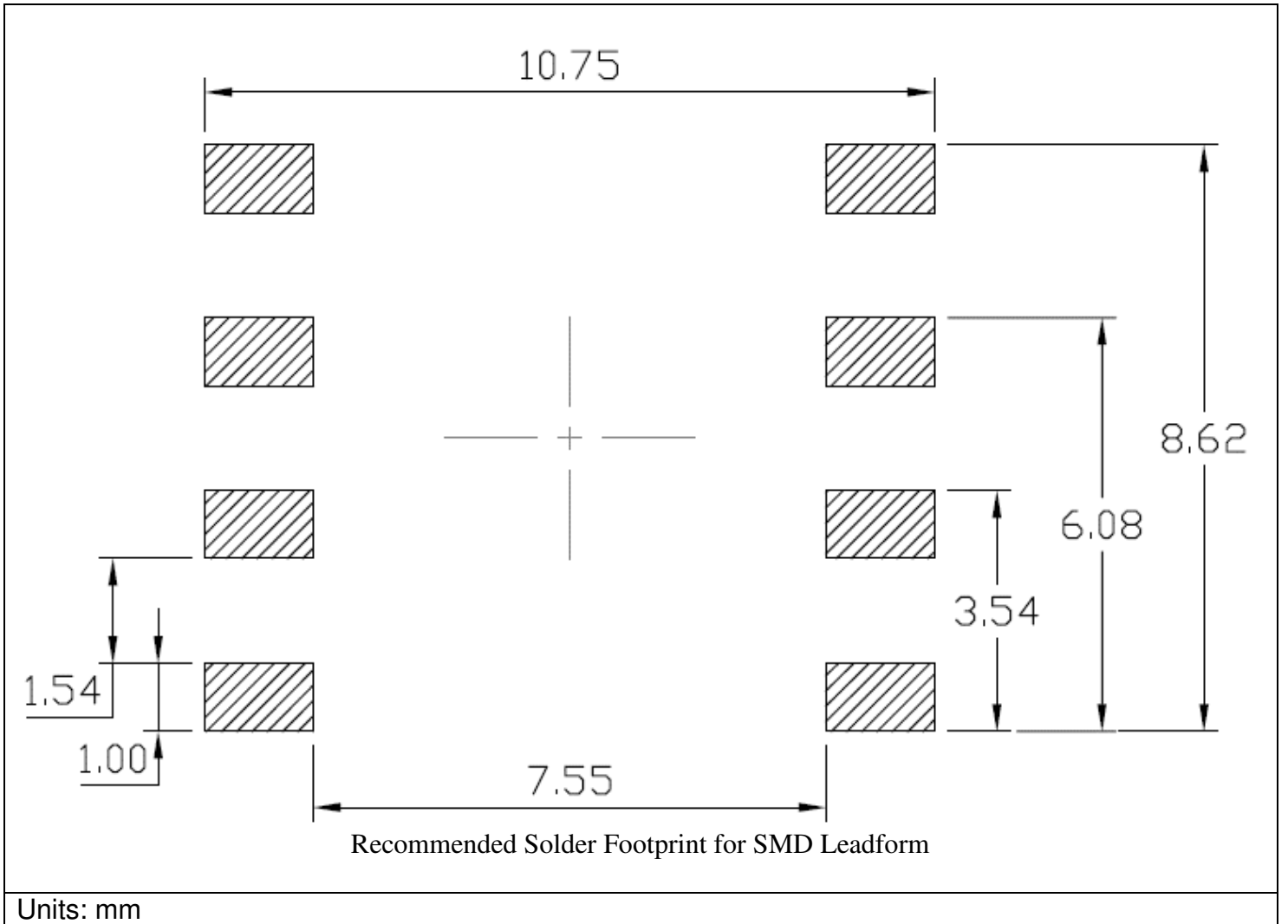

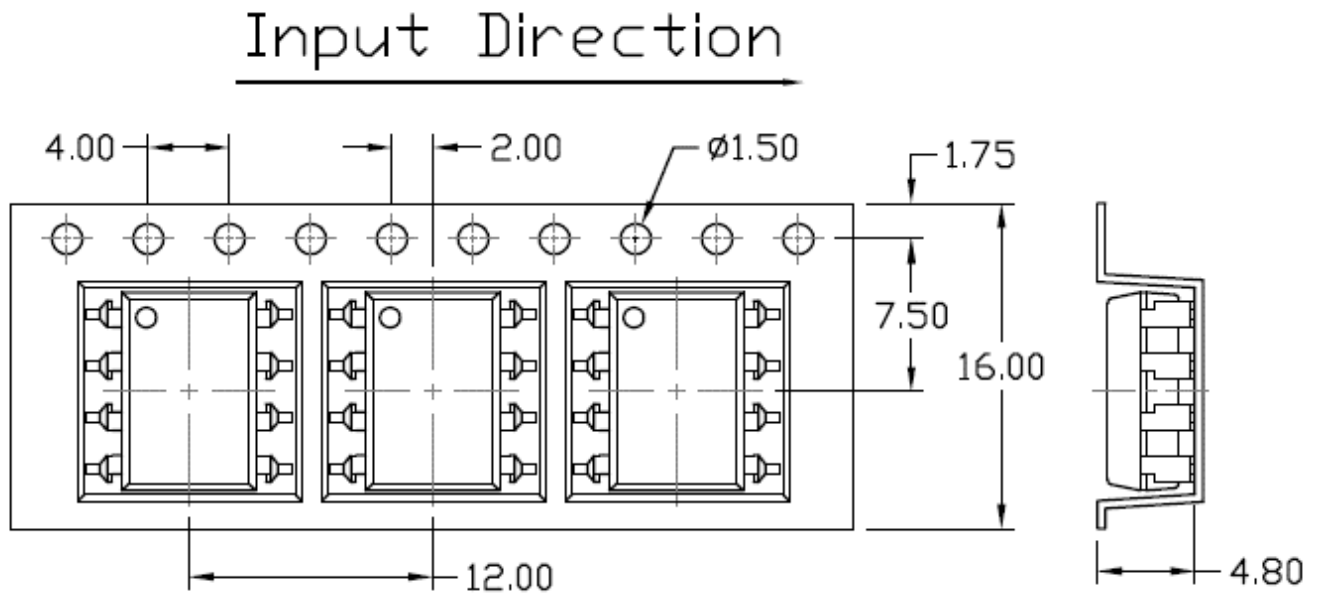
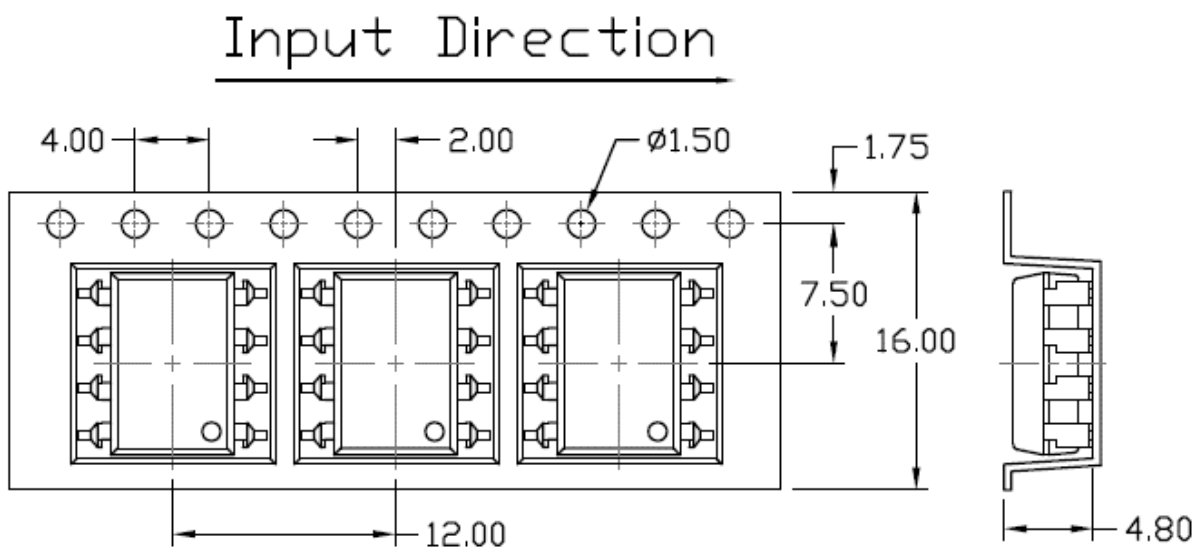
Packing & Labeling**Tape Dimension:****Option S(T1) & SL(T1)****Option S(T2) & SL(T2)**

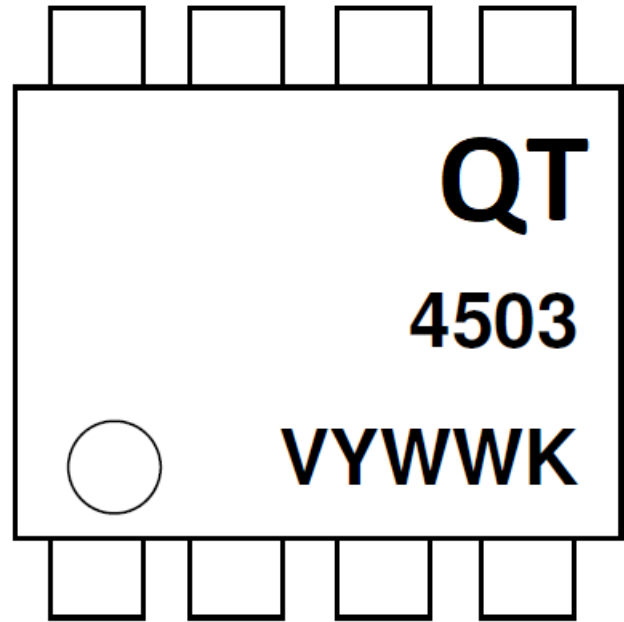
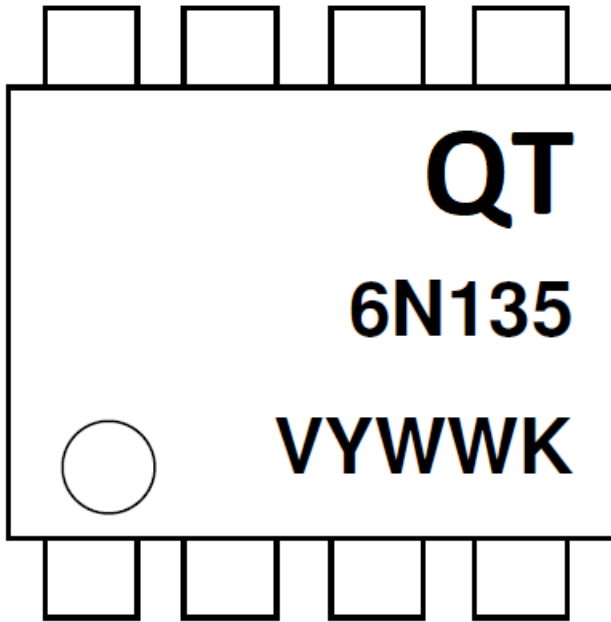
Device Marking

QT = QT-Brightek Corporation
6N135 = part number
Y = Year
WW = Week
V = VDE Option
K = Manufacturing code

Ordering Information

6N13X(V)(Y)(Z) or QT450X(V)(Y)(Z)

XX = Part number (5,6 for 6N13X series), (2,3 for QT450X series)

V = VDE option (V or None)

Y = Lead form option (S, SL, M or none)

Z=Tape and reel option (T1 or T2)

Option	Description	Quantity
None	Standard 4-Pin DIP	40 Units/Tube
M	Gullwing	40 Units/Tube
S(T1)	Surface Mount Lead Forming – with Option 1 Taping	1000 pcs/ reel
S(T2)	Surface Mount Lead Forming – with Option 2 Taping	1000 pcs/ reel
SL(T1)	SMD (Low Profile) Lead Forming – with Option 1 Taping	1000 pcs/ reel
SL(T2)	SMD (Low Profile) Lead Forming – with Option 2 Taping	1000 pcs/ reel



Revision History

Description:	Revision #	Revision Date
Initial release of 6N135_6N136_QT4502_QT4503	1.0	02/12/2018

Disclaimer

QT-BRIGHTTEK reserves the right to make changes without further notice to any products herein to improve reliability, function or design. QT-BRIGHTTEK does not assume any liability arising out of the application or use of any product or circuit described herein; neither does it convey any license under its patent rights, nor the rights of others.

Life Support Policy

QT-BRIGHTTEK's products are not authorized for use as critical components in life support devices or systems without the express written approval of QT-BRIGHTTEK. As used herein:

1. Life support devices or systems are devices or systems which, (a) are intended for surgical implant into the body, or (b) support or sustain life, and (c) whose failure to perform when properly used in accordance with instructions for use provided in the labeling, can be reasonably expected to result in a significant injury of the user.
2. A critical component in any component of a life support device or system whose failure to perform can be reasonably expected to cause the failure of the life support device or system, or to affect its safety or effectiveness.