

## Pi RTC (DS1307)

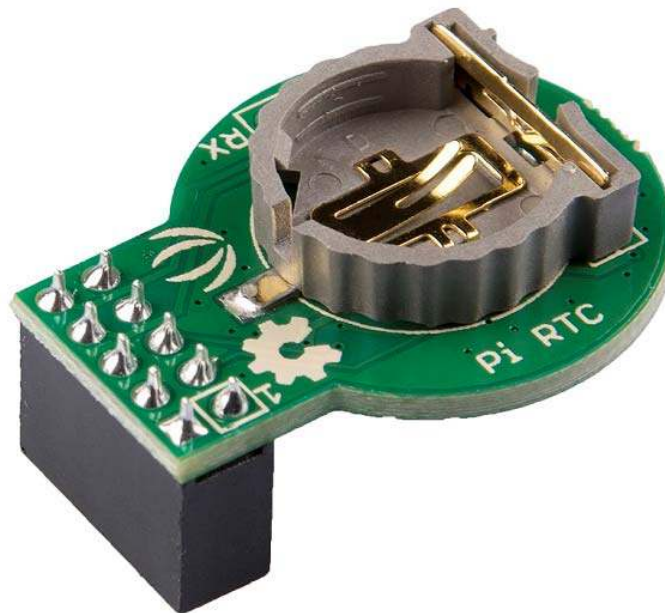

The Pi RTC is based on the clock chip DS1307, it can provide a real-time clock(RTC) for raspberry pi via the I2C interface. Real-time clock of this module counts seconds,minutes, hours, date of the month,month, day of the week, and year with leap-year compensation valid up to 2100. The clock operates in either the 24-hour or 12-hour format with AM/PM indicator. If you want to keep this module timing when the Raspberry Pi is powered off, you need to put a 3-Volt CR1225 lithium cell in the battery-holder.

### Note

The battery is not included.

### Features

- Support Raspberry Pi 2/ 3 B/B+ Zero
- Support seconds,minutes,hours,day of week,month, year
- Support 24-hour or 12-hour format with AM/PM indicator
- 56-byte, battery-backed, nonvolatile (NV) RAM for data storage
- Two-wire serial interface
- Programmable squarewave output signal
- Automatic power-fail detect and switch circuitry

## Specification

Item	Value
Operating Voltage	5V
Interface	I2C
I2C Address	0x68

## Typical applications

Any applications need Real Time on Raspberry.

## Pin Out

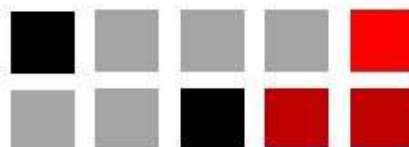
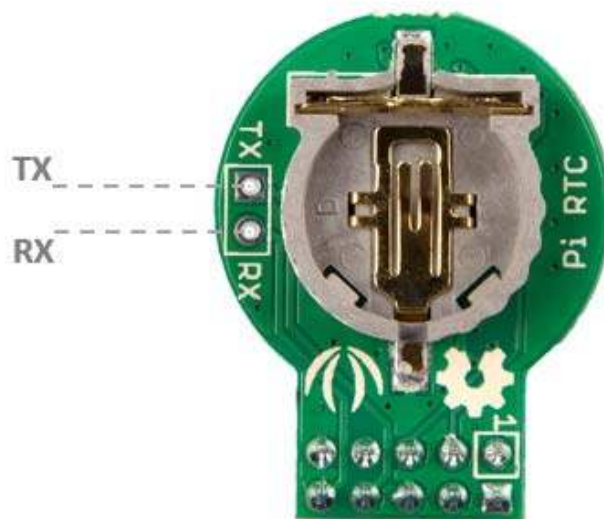

GND	GPIO7	SCL_3V3	SDA_3V3	3V3
RX	TX	GND	5V	5V

### Note

RX/TX is not used in this module, but the 5x2 header takes up the RX/TX pin of the Raspberry Pi, so we bring the RX/TX out and come with a 2pin header.

## Schemaitc

### Bi-directional level shifter circuit

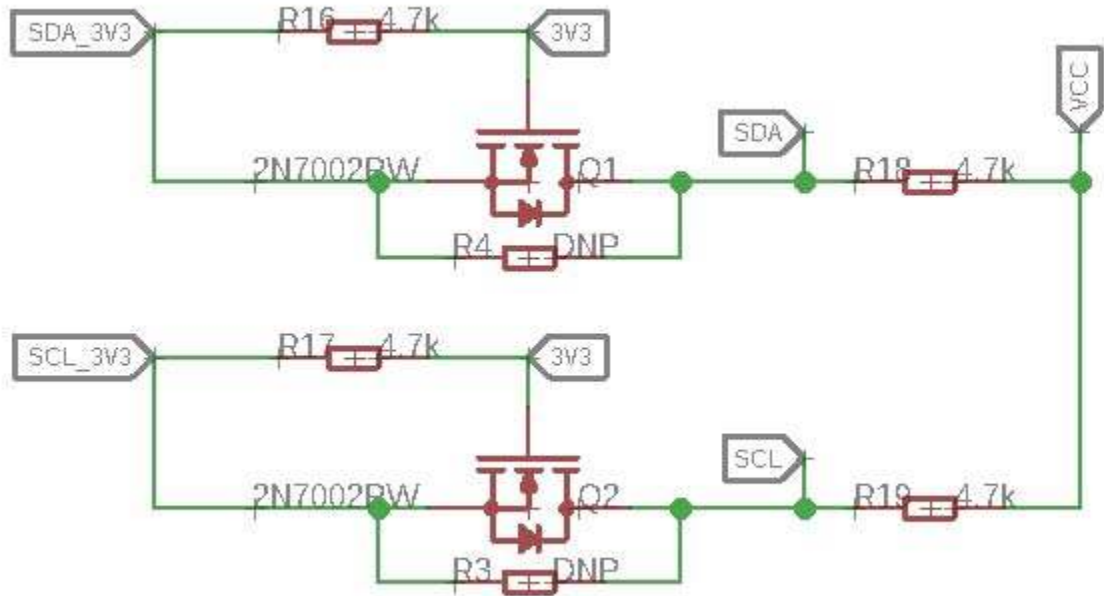



This is a typical Bi-directional level shifter circuit to connect two different voltage section of an I<sup>2</sup>C bus. The I<sup>2</sup>C bus of Raspberry Pi uses 3.3V, however the chip DS1307 works at 5V, so this circuit will be needed. In the schematic above, **Q1** and **Q2** are N-Channel MOSFET [2N7002A](#), which act as a bidirectional switch. In order to better understand this part, you can refer to the [AN10441](#)

## Platforms Supported

Arduino	Raspberry Pi	BeagleBone	Wio	LinkIt ONE

## Getting Started

### Materials required

Raspberry Pi	Pi RTC(DS1307)
	

#### Note

Please plug the USB cable gently, otherwise you may damage the port. Please use the USB cable with 4 wires inside, the 2 wires cable can't transfer data. If you are not sure about the wire you have, you can click [here](#) to buy

## Install

The driver we provide only applied for Raspbian Jessie/Stretch.

#### Tip

If you do not know how to use a raspberry pi, please check [here](#) before start.

- **Step 1. Driver Installation**

Tap the following command in your terminal

```
1 git clone https://github.com/Seeed-Studio/pi-hats.git
```

When the download finish, tap the following command in your terminal

```
1 cd pi-hats
2 sudo ./install.sh -u rtc_ds1307
```

- **Step 2. Power off Raspberry Pi**

```
1 sudo shutdown -h now
```

- **Step 3. Insert the HAT to Raspberry Pi**



Please make sure plug the pin 1 of this hat into the pin 1 of raspberry GPIO, just like the picture above.

- **Step 4. Power up Raspberry Pi**

## Usage

Now you can use the command to check whether the driver is installed successfully.

```
1 ./install.sh -l
```

If you want uninstall the driver you can use the command below:

```
1 sudo ./install.sh -u
```

Now let's see what the RTC module can do:

---

Read hardware clock and print result

```
1 sudo hwclock -r
```

---

Set the system time from the hardware clock

```
1 sudo hwclock -s
```

---

Set the hardware clock from the current system time

```
1 sudo hwclock -w
```

---

More usage

```
1 hwclock --help
```

## Tech Support

Please do not hesitate to submit the issue into our [forum](#)