

VCTS-Z | Safety lobe knobs

Technopolymer, push action

INCH

INOX
STAINLESS
STEEL

RoHS

PA

+266 °F
-22 °F

- 1
- 2
- 3
- 4
- 5
- 6
- 7
- 8
- 9
- 10
- 11
- 12
- 13
- 14
- 15
- 16
- 17
- 18

KNOB

Glass-fibre reinforced polyamide based (PA) technopolymer. Built-in zinc alloy toothed insert for coupling to the metal clamping element, black colour, matte finish.

CENTRE CLOSING CAP

Black technopolymer centre cap. On request and for sufficient quantities, it can be supplied in yellow RAL 1021 (safety) or in other colours, with customised graphic symbols, marks or writings.

STANDARD EXECUTIONS

The clamping element has a toothed element for coupling to the zinc alloy insert moulded in the knob.

- **VCTS-Z:** black-oxide clamping element with threaded hole, black-oxide steel retaining screw. AISI 302 stainless steel return spring.
- **VCTS-Z-SST:** AISI 303 stainless steel clamping element with threaded hole, AISI 303 stainless steel retaining screw. AISI 302 stainless steel return spring.
- **VCTS-Z-p:** black-oxide steel clamping element with threaded pin, black-oxide steel retaining screw. AISI 302 stainless steel return spring.
- **VCTS-Z-SST-p:** AISI 303 stainless steel clamping element with threaded pin, AISI 303 stainless steel retaining screw. AISI 302 stainless steel return spring.

FEATURES AND APPLICATIONS

Particularly suitable where the knob needs to turn freely to avoid that clamping may be accidentally affected.

OTHER EXECUTIONS ON REQUEST

Standard metric holes and threaded studs.

INSTRUCTIONS

Press the knob to engage the toothing and turn it. By releasing the knob the spring releases the toothing, thus the knob returns to the rest position.



ELESA Original design

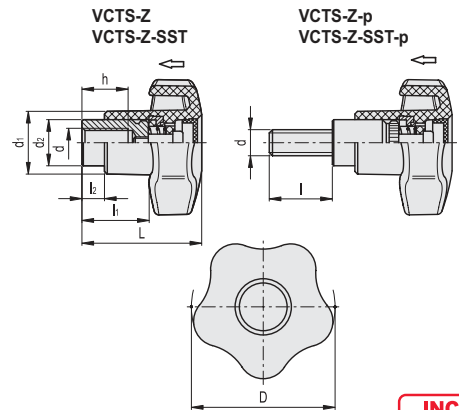

INCH

VCTS-Z

Code	Description	D	d	L	d1	d2	l1	l2	h	Teeth nr	⚖
969632	VCTS-Z-40 A-5/16-18	1.57	5/16-18	1.46	0.71	0.53	0.87	0.28	0.39	24	0.07
969643	VCTS-Z-50 A-3/8-16	1.97	3/8-16	1.65	0.87	0.63	0.91	0.31	0.55	26	0.11

INOX
STAINLESS
STEEL

INCH

VCTS-Z-SST

Code	Description	D	d	L	d1	d2	l1	l2	h	Teeth nr	⚖
969652	VCTS-Z-40-SST-5/16-18	1.57	5/16-18	1.46	0.71	0.53	0.87	0.28	0.39	24	0.09
969663	VCTS-Z-50-SST-3/8-16	1.97	3/8-16	1.65	0.87	0.63	0.91	0.31	0.55	26	0.13

INCH

VCTS-Z-p

Code	Description	D	d	L	d1	d2	l	l1	l2	Teeth nr	⚖
969731	VCTS-Z-40 p-1/4-20-079	1.57	1/4-20	1.46	0.71	0.53	0.98	0.87	0.28	24	0.1
969742	VCTS-Z-40 p-5/16-18-098	1.57	5/16-18	1.46	0.71	0.53	0.98	0.87	0.28	24	0.11
969752	VCTS-Z-50 p-3/8-16-126	1.97	3/8-16	1.65	0.87	0.63	1.26	0.91	0.31	26	0.15
969763	VCTS-Z-50 p-1/2-13-126	1.97	1/2-13	1.65	0.87	0.63	1.26	0.91	0.31	26	0.16

INOX
STAINLESS
STEEL

INCH

VCTS-Z-SST-p

Code	Description	D	d	L	d1	d2	l	l1	l2	Teeth nr	⚖
969782	VCTS-Z-40-SST-p-5/16-18-079	1.57	5/16-18	1.46	0.71	0.53	0.98	0.87	0.28	24	0.11
969802	VCTS-Z-50-SST-p-3/8-16-126	1.97	3/8-16	1.65	0.87	0.63	1.26	0.91	0.31	26	0.16