

10	9	8	7
MATERIAL	ENG-NUMBER	LENGTH	LENGTH TOL.
1300290005	405007D12M010	1M (3'-4")	+58.7MM -0(+2.31" -0")

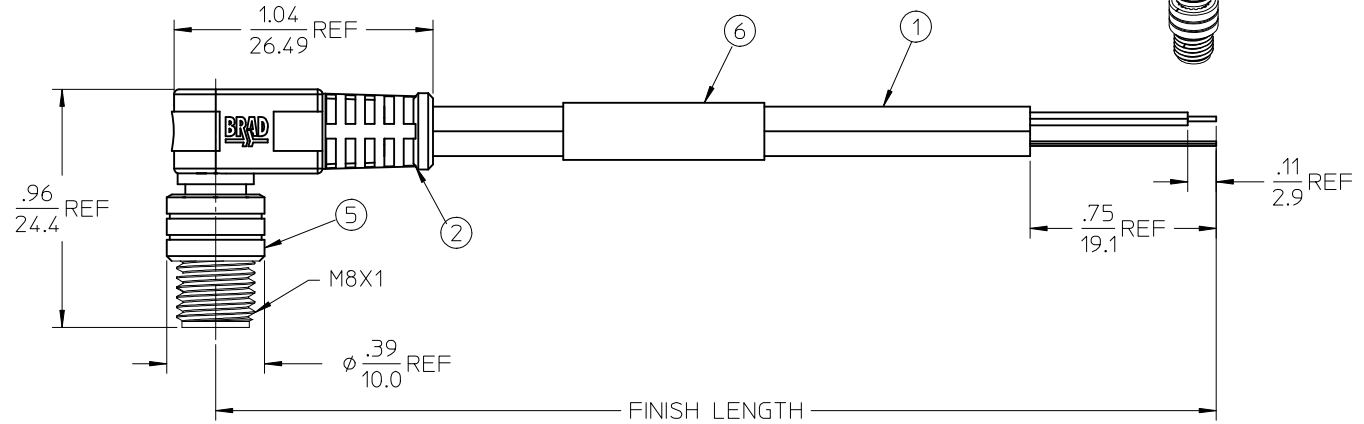

NOTES:

- 1.) MATERIAL: SEE TABLE
- 2.) FINISHES: SEE TABLE
- 3.) ELECTRICAL: 60VAC 75VDC, 1.68 AMPS
- 4.) CABLE:  
TWO SHIELDED PAIRS  
26AWG/ 4C 300VDC  
-20 TO +70°C @ 1.68 AMPS
- 5.) IP67
- 6.) ASSEMBLY IS RoHS COMPLIANT

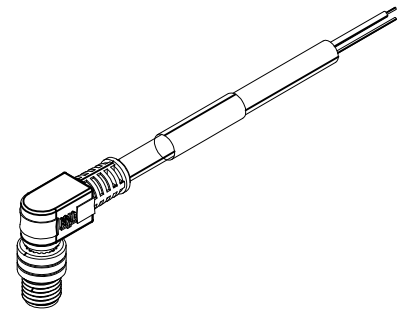
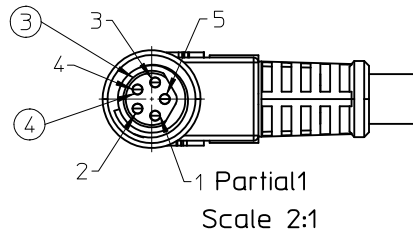

WIRING CONNECTION

1	BARE	DRAIN
2	RED	V+
3	WHITE	CAN_H
4	BLACK	V-
5	BLUE	CAN_L

6	1	MFG LABEL	PLASTIC FILM	BLACK/YELLOW
5	1	MALE COUPLING NUT	BRASS	NICKEL PLATED
4	5	MALE CONTACT	Cu ALLOY	GOLD PLATED
3	1	NC 5 POLE MALE INSERT	PUR	BLACK
2	1	OVERMOLD BODY	TPE	GRAY
1	1	CABLE, 4P, 26 AWG	PVC JACKET	GRAY
ITEM	QTY	DESCRIPTION	MATERIAL	FINISH

CREATE DOC.  
EC NO: WNA2010-0452  
DRAWN: BRUPERT 2010/01/25  
CHKD: B. WOODMAN 2010/01/29  
APPR: J. MURPHY 2010/01/29

QUALITY SYMBOLS  
▽=0  
▽=0

GENERAL TOLERANCES (UNLESS SPECIFIED)

	mm	INCH
4 PLACES	± .---	± .---
3 PLACES	± .---	± .---
2 PLACES	± .---	± .---
1 PLACE	± .---	± .---

ANGULAR ±1/2°

DRAFT WHERE APPLICABLE MUST REMAIN WITHIN DIMENSIONS

DIMENSION STYLE IN/MM

SCALE 2:1

DESIGN UNITS INCH

THIRD ANGLE PROJECTION

TITLE NC 5P 90D MALE DEVICENET

MOLEX INCORPORATED

DOCUMENT NO. SD-130029-005

SHEET NO. 1 OF 1