

REVISIONS			
REV.	DESCRIPTION	DATE	APPROVED
A	INITIAL RELEASE	03/13/18	D.N.

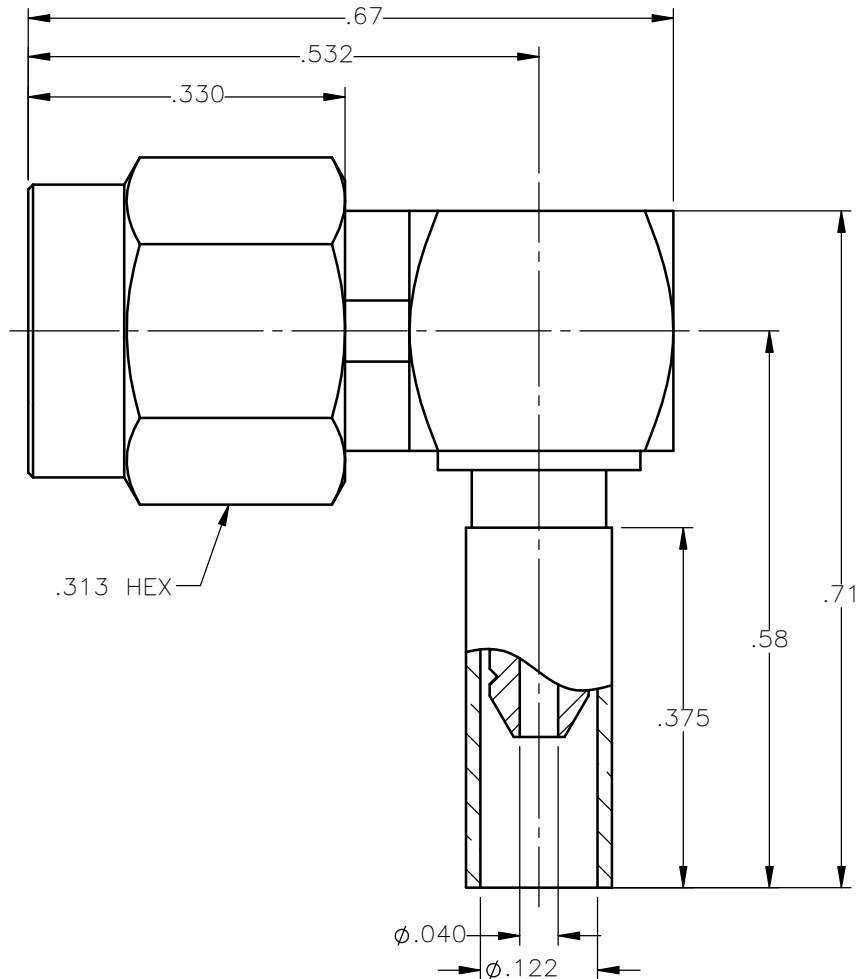

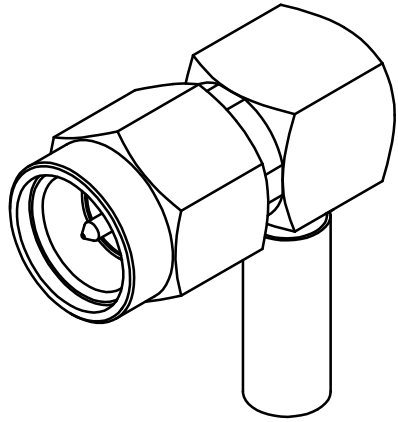

NOTES:

MATERIALS:

- BODIES & COUPLING NUT = STAINLESS STEEL PER ASTM A582, ALLOY 303, CONDITION "A".
- CONTACT & RETAINING RING = BERYLLIUM COPPER PER ASTM B196, ALLOY C17300, TEMPER TD04.
- INSULATORS = VIRGIN WHITE TEFLON PER ASTM D1710, GRADE 1, TYPE I, CLASS "B".
- GASKET = SILICONE RUBBER PER ZZ-R-765, CLASS 2B, GRADE 65-75.
- CAP = BRASS PER ASTM B16, ALLOY C36000, TEMPER H02.
- CRIMP SLEEVE = SEAMLESS LOWLEAD BRASS TUBE, ALLOY 330, SOFT ANNEAL TEMPER, .025/.060 GRAIN SIZE OR SEAMLESS COPPER TUBE PER ASTM B75, TYPE C12000, TEMPER: LIGHT ANNEAL O50 EXCEPT YIELD STRENGTH.
- SHRINK SLEEVE = (NOT SHOWN) THERMOFIT SCL, BLACK.

FINISHES:

- BODIES = GOLD PLATE PER ASTM B488-11, TYPE II, 30 $\mu$ in MIN, GRADE C, OVER 50 TO 100 $\mu$ in STRESS FREE NICKEL PER AMS-QQ-N-290.
- COUPLING NUT = PASSIVATE PER SAE-AMS-2700
- CONTACT = GOLD PLATE PER ASTM B488-11, TYPE II, 50 $\mu$ in MIN, GRADE C, OVER 100 TO 200 $\mu$ in STRESS FREE SULFAMATE NICKEL PER AMS-QQ-N-290.
- CRIMP SLEEVE & CAP = GOLD PLATE PER ASTM B488-11, TYPE II, 30 $\mu$ in MIN, GRADE C OVER 100 TO 200 $\mu$ in COPPER STRIKE PER AMS 2418.

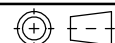
UNLESS OTHERWISE SPECIFIED DIMENSIONS ARE IN INCHES TOLERANCES ON	DWN: DATE	 <b>Property of Radiall</b> This document cannot be reproduced or communicated to a third party without prior written permission of RADIALL.	
	D.N. DATE		
DECIMAL	ANGLE	CHKD: DATE	<b>SMA RIGHT ANGLE PLUG          CRIMP TYPE          FOR RG-178 &amp; SIMILAR CABLES</b>
		C.E. DATE	
		APVD: DATE	
REFERENCE:	MATERIALS & FINISHES:	J.M. DATE	SIZE: A FSCM NO.: 19505 DWG NO.: 9043-1523-002 REV: A
ORIGINATED: D.N. DATE: 03/13/18	SEE NOTES		SCALE: 5:1 THIRD ANGLE PROJECTION  SHEET 1 OF 1

9043-1523-002