

TYPE 2C

Application Tooling Specification Sheet

Tool Kit
Order No. 63811-6470

Hand Crimp Tool
Order No. 63811-6400

FEATURES

- % A full cycle ratcheting hand tool ensures complete crimps
- % Ergonomically designed soft handles
- % Precisely designed crimping profiles with simple contact positioning
- % Easy handling due to outstanding force ratio
- Tool kits are easily installed into the Hand Crimp Tool or the 63816-0300 Power Crimp Head which is installed into the 63816-0200 (110 V) or the 63816-0250 (220 V) Battery Powered Tool.
- Many different Tool kits can be used with a single Battery Powered Tool.
- This tool is IPC/WHMA-A-620 Class 2 and RoHS compliant.

SCOPE

Products: 1.50mm (.059") Pico-SPOX™ Crimp Terminal, Female, 24-30 AWG.

| Terminal Series No. | Terminal Order No. | Wire Size | | Wire Type | | *Insulation Diameter Maximum | | Strip Length | | |
|---------------------|--------------------|------------------------------|--------|-----------------|--------|------------------------------|------|--------------|-----------|-----------|
| | | *Available in Reel form only | AWG | mm ² | AWG | Type | mm | In. | mm | In. |
| 87421 | 87421-0000 | | 24 | 0.20 | 24 | UL1061 | 1.15 | .045 | 1.05-1.54 | .041-.061 |
| | | | 26-30 | 0.12-0.05 | 26 | UL1061 | | | | |
| | | 28 | | | UL1061 | | | | | |
| | | 30 | UL1571 | | | | | | | |

*Customer to cut off terminal from reel: 0.29mm (.011") maximum Cut-off Tab.
*See Conditions on page 2.

DEFINITION OF TERMS

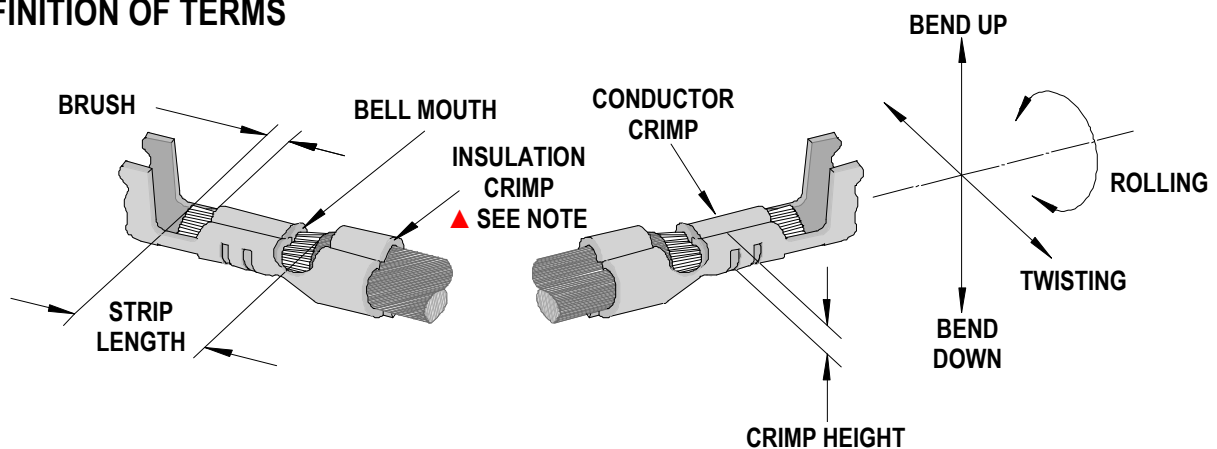

▲ Insulation Crimp Note:

Due to the terminal’s insulation grip design and/or insulation diameter range, this tool uses “overlap” form geometry in the insulation punch. This produces an overlap insulation crimp (A620 – compliant). While the insulation punch profile may appear “lopsided”, this is a normal condition for this tool. See figure to the right. (Some tools with multiple crimp pockets may not have the “overlap” profile on all pockets).

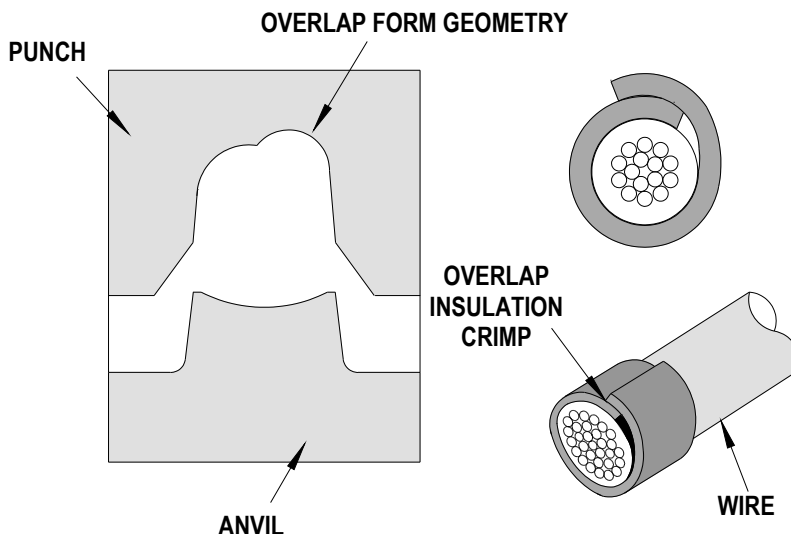

After crimping, the conductor profiles should measure the following (see notes below).

| Terminal Series No | Wire Size | | Conductor Crimp | | | | ●Insulation Crimp | | | | Pull Force Minimum | | *Profile | |
|--------------------|-----------|-----------------|-----------------|-----------|--------------|------|-------------------|------|--------------|------|--------------------|------|----------|---|
| | | | Height (Ref.) | | Width (Ref.) | | Height (Ref.) | | Width (Ref.) | | | | | |
| | AWG | mm ² | mm | In. | mm | In. | mm | In. | mm | In. | N | Lb. | A | B |
| 87421 | 24 | 0.20 | 0.56-0.60 | .022-.024 | 1.00 | .039 | 1.40 | .055 | 1.10 | .043 | 29.4 | 6.60 | X | |
| | 26 | 0.12 | 0.52-0.58 | .020-.023 | 1.00 | .039 | 1.24 | .049 | 1.10 | .043 | 19.6 | 4.40 | | X |
| | 28 | 0.08 | 0.52-0.58 | .020-.023 | 1.00 | .039 | 1.24 | .049 | 1.10 | .043 | 9.8 | 2.20 | | X |
| | 30 | 0.05 | 0.52-0.58 | .020-.023 | 1.00 | .039 | 1.24 | .049 | 1.10 | .043 | 6.7 | 1.50 | | X |

*To Achieve IPC-A-620 Class 2 Crimps, the following over-all wire insulation diameter ranges are recommended:
 Profile A: 1.00-1.15mm (.039-.045 inch)
 Profile B: 0.65-1.00mm (.025-.039 inch)

Tool Qualification Notes:

1. Pull Force should be measured with no influence from the insulation crimp.
2. The above specifications are guidelines to an optimum crimp.

Note:

A crimp height chart is provided with this manual as Reference Only. Due to the wide range of wires, strands, insulation diameters, and durometers, actual crimp height measurements may vary slightly. An occasional, destructive, pull force test should be performed to check hand tool crimp. Pull Force value Must exceed the Minimum pull force specifications listed this page.

CAUTION: Install only Molex terminals listed above with this tool. Do not crimp hardened objects as damage can occur to the tool or die.

INSTALLATION

To install the Tool Kit into the Power Crimp Head follow the steps below:

Anvils and Punches Installation

1. Insert the Anvils into the bottom slots of the nest. Install the M4 x 10 long BHCS and tighten in place.
2. Insert the Punches into the top slots of the nest. Install the M4 x 18 long BHCS and tighten in place. See Figure 1.

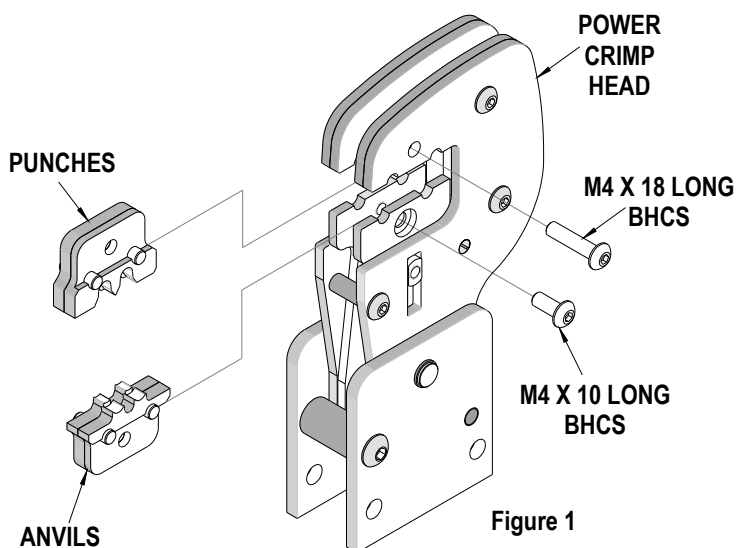

Figure 1

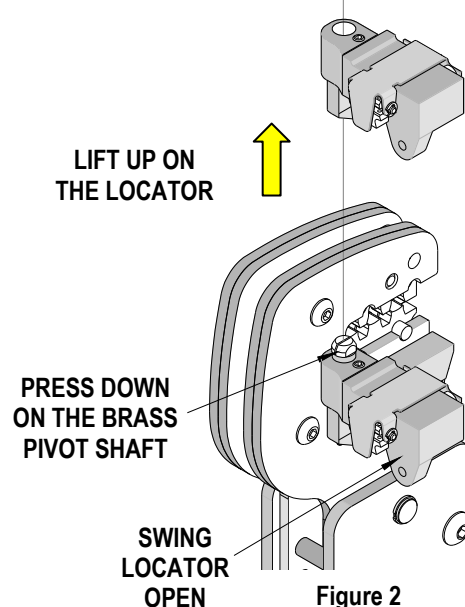

Figure 2

Locator Installation and Removal

Follow the steps below to install or replace the locator. See Figure 2.

To install the locator

1. Position the locator with the hole over the brass pivot shaft and snap it into place.

To remove the locator

1. Open the crimp hand tool.
2. Swing the existing locator open and away from the hand tool.
3. Firmly press down on the brass pivot shaft with your thumb, while pulling the locator up. Slip the locator off the top of the brass pivot shaft.

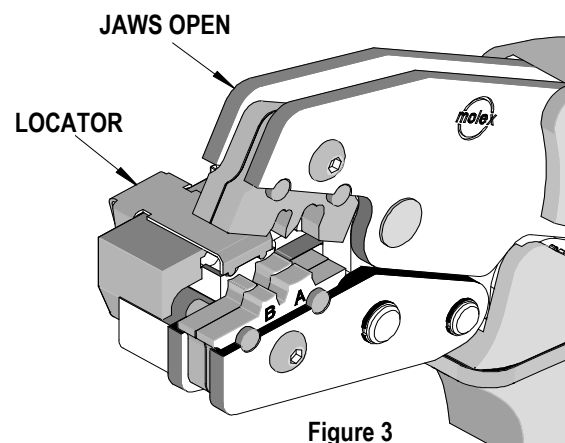

Figure 3

OPERATION

Open the tool by squeezing the handles together, at the end of the closing stroke, the ratchet mechanism will release the handles, and the hand tool will spring open.

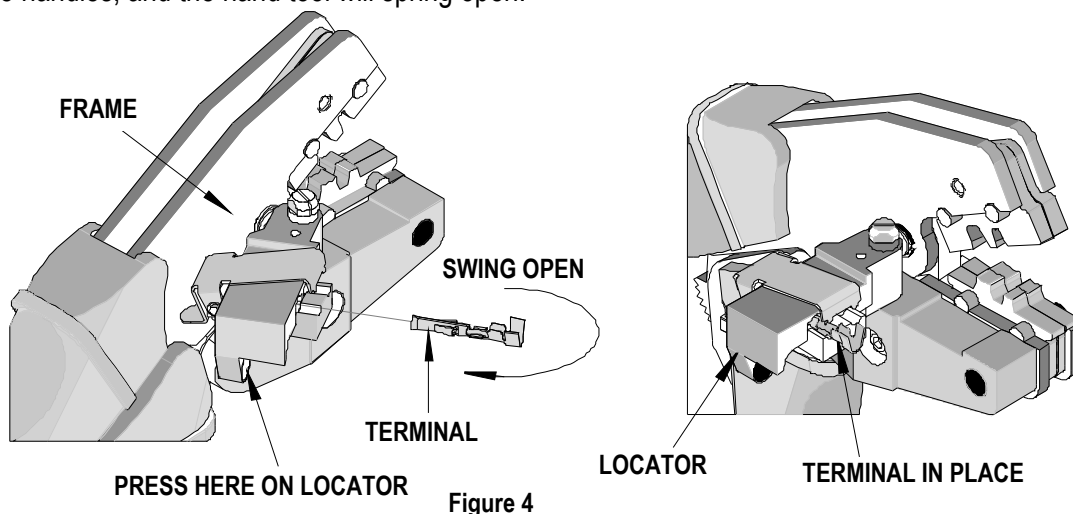
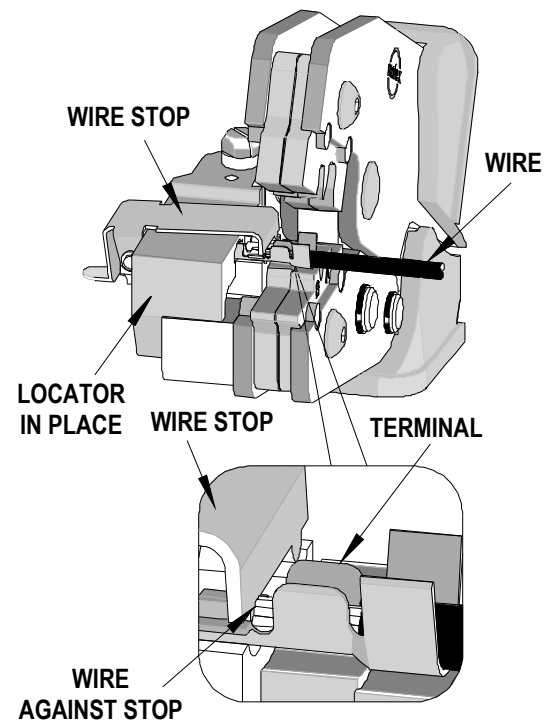

Figure 4

Crimping Terminals

1. Select the desired terminal listed in the preceding charts.
2. Swing the terminal locator away from the crimp tool shown in Figure 4. Gently press on the locator to open the wire stop. Some terminals with large insulation grips may interfere with the crimp tooling when swinging the locator into position. The terminal must then be loaded into the locator in the closed/crimp position.
3. When using the locator, swing the locator away from the crimp tool, and gently press the locator against the tool frame as shown in Figure 4. The wire stop will automatically open. Insert the proper terminal into the proper nest opening. Make sure when choosing the nest opening, it will correspond with the A or B profile on the hand tool.
4. Return the locator to its original position.
5. Insert the proper wire over the terminal. Some large O.D. wires may need to be placed into the terminal before closing the tool. Gently touch the wire stop with the end of the wire. See Figure 5.
6. Compress the terminal by squeezing the tool handles until the ratchet mechanism cycle has been completed. Release handles to open the jaws.
7. Remove the crimped terminal from the terminal locator by pressing down on the wire stop and gently pulling on the wire. The terminal locator can be in either position.
8. Visually inspect the crimped terminal for proper crimp location.



Note: The tamper proof ratchet action will not release the tool until it has been fully closed.

Locator Replacement

See the parts list on the last page of this document for the proper locator order number. Follow the steps below to replace the locator.

1. Open the crimp hand tool.
2. Swing the existing locator open and away from the hand tool.
3. Firmly press down on the brass pivot shaft with your thumb, while pulling the locator up. Slip the locator off the top of the brass pivot shaft. See Figure 6.
4. Replace it with the proper locator by putting over the brass pivot shaft and snapping it into place.

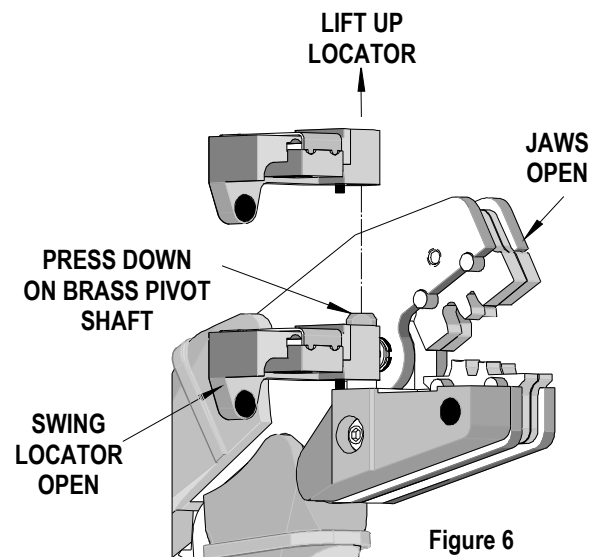

For the Battery Power Tool:

1. Cycle the Battery Power Tool to crimp the terminal to the wire.
2. Remove the crimped terminal from the terminal locator by pressing down on the wire stop and gently pulling on the wire. The terminal locator can be in either position.
3. Visually inspect the crimped terminal for proper crimp location.

Maintenance

It is recommended that each operator of the tool be made aware of, and responsible for, the following maintenance steps:

1. Remove dust, moisture, and other contaminants with a clean brush, or soft, lint free cloth.
2. Do not use any abrasive materials that could damage the tool.
3. Make certain all pins; pivot points and bearing surfaces are protected with a thin coat of high quality machine oil. Do not oil excessively. The tool was engineered for durability but like any fine piece of equipment it needs cleaning and lubrication for a maximum service life of trouble free crimping. Use a 30 weight automotive (light) oil used at the oil points, every 5,000 crimps or 3 months, shown in Figure 7A or 7B will significantly enhance the tool life.
4. Wipe excess oil from hand tool, particularly from crimping area. Oil transferred from the crimping area onto certain terminations may affect the electrical characteristics of an application.
5. When tool is not in use, keep the handles closed to prevent objects from becoming lodged in the crimping dies, and store the tool in a clean, dry area.

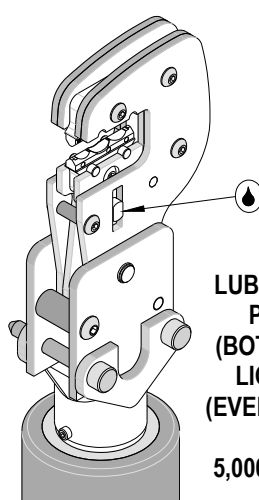

Figure 7A

LUBRICATION POINTS
(BOTH SIDES)
LIGHT OIL
(EVERY MONTH
OR
5,000 CRIMPS)

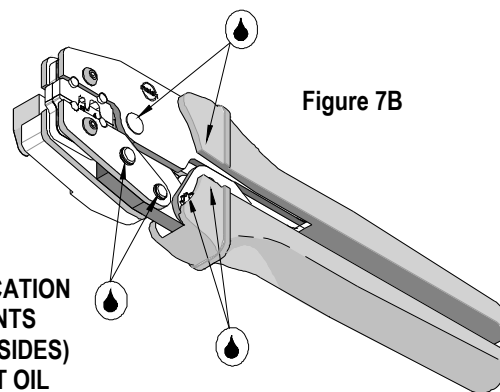

Figure 7B

Miscrimps or Jams

Should this tool ever become stuck or jammed in a partially closed position, **Do Not force the handles open or closed.** The tool will open easily by pressing the ratchet release lever. See Figure 8.

How to Adjust Tool Preload (See Figure 8)

This hand tool is factory preset to 25-45 LBS.

preload. It may be necessary over the life of the tool to adjust tool handle preload force. Listed below are the steps required to adjust the crimping force of the hand tool to obtain proper crimp conditions:

1. Remove or fold back the handle grip from the handle to expose the eccentric axle and setting wheel.
2. Remove the locking screw with a 2mm hex wrench. The wrench set (63810-0101), is not supplied. It is sold separately from the hand tool.
3. Turn the eccentric axle and setting wheel with the wrench or pliers Counter-clockwise (CCW) to increase handle force.
4. Replace the locking screw, aligning the nearest notch in the setting wheel to locking screw.
5. Replace the handle grip.
6. Check the crimp specifications or conduct a pull test after tool handle preload force is adjusted.

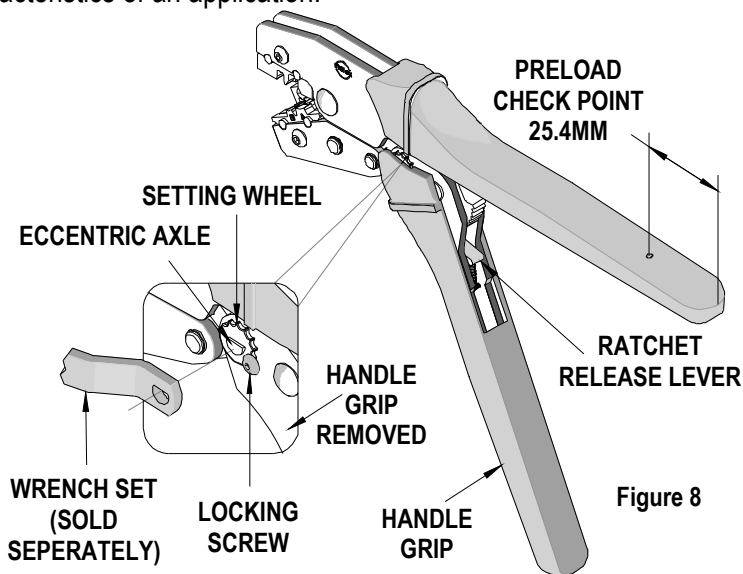

Figure 8

Warranty

This tool is for electrical terminal crimping purposes only. This tool is made of the best quality materials. All vital components are long life tested. All tools are warranted to be free of manufacturing defects for a period of 30 days. Should such a defect occur, we will repair or exchange the tool free of charge. This repair or exchange will not be applicable to altered, misused, or damaged tools. This tool is designed for hand use only. Any clamping, fixturing, or use of handle extensions voids this warranty.

CAUTION: Molex crimp specifications are valid only when used with Molex terminals and tooling.

CAUTIONS

1. Manually powered hand tools are intended for low volume or field repair. This tool is **NOT** intended for production use. Repetitive use of this tool should be avoided.
2. Insulated rubber handles are not protection against electrical shock.
3. Wear eye protection at all times.
4. Use only the Molex terminals specified for crimping with this tool.

Certification

Molex does not certify or re-certify commercial grade hand tools but rather supplies the following guidelines for customers to re-certify hand tools.

- % This tool is qualified to pull force only. To re-certify, crimp a terminal to a wire, which has been stripped 12.7mm (1/2") long, so there is no crimping of the insulation. Pull the terminal and wire at a rate no faster than 25mm (1.00") per minute. See the Molex web site for the Quality Crimp Handbook for more information on pull testing.
- % If the tool does not meet minimum pull force values, handle preload should be increased and the pull test rerun, (See How To Adjust Preload).
- % When the hand tool is no longer capable of achieving minimum pull force, it should be taken out of service and replaced.

The chart below shows all applications for this Tool Kit.

| Tool Kit Order No. | Tool Order no. | Tool Description | Power Head Order No. | Adapter Description | Figure No. |
|--------------------|----------------|----------------------------|----------------------|---------------------|------------|
| 63811-6470 | 63810-0100 | Hand Crimp Frame (Short) | N/A | N/A | 9 |
| | 63810-0400 | Hand Crimp Frame (Long) | N/A | N/A | 9 |
| | 63816-0200 | Battery Power Tool (110 V) | 63816-0300 | Power Crimp Head | 10 |
| | 63816-0250 | Battery Power Tool (220 V) | 63816-0300 | Power Crimp Head | 10 |

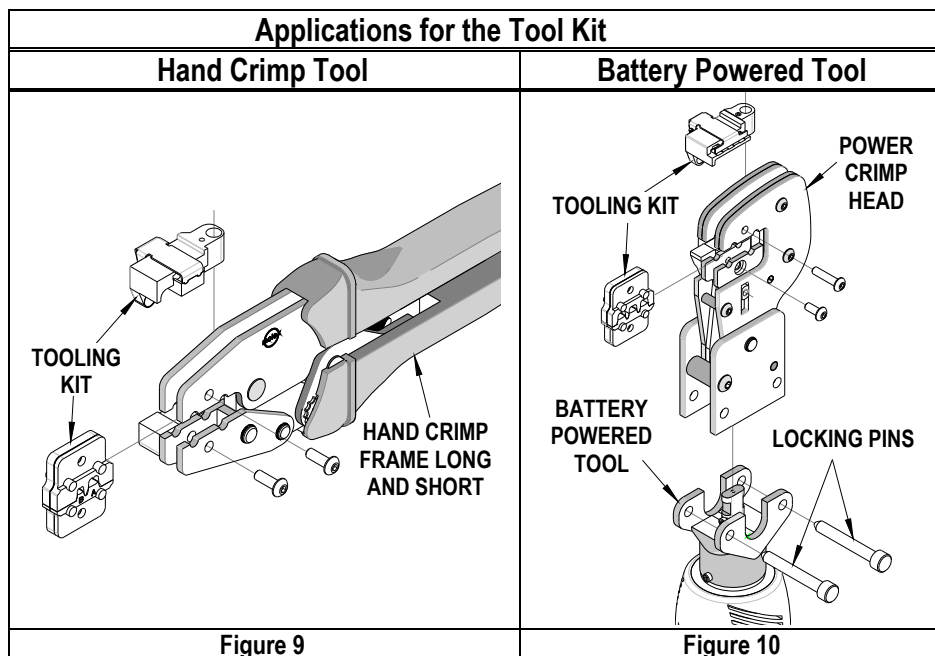

WARNING: NEVER operate service, install tool kits, or adjust the Power Crimp Head without proper instruction and without first reading and understanding the instructions in the proper Manual or Specification Sheet. See Chart above for the correct Manual or Specification Sheet.

WARNING: NEVER install tooling or service this tool while it is into any power source. Make sure the power is turned off.

CAUTION: Keep fingers away from the crimping area when operating this tool. It may cause severe injury.

CAUTION: Wear safety glasses when operating or serving this tool.

HAND TOOL PARTS LIST

| Item Number | Order Number | Description | Quantity |
|-------------|--------------|---------------------------|----------|
| 1 | 63810-0100 | Hand Crimp Frame (Short) | 1 |
| 2 | 63810-0101 | Wrench Set (Not included) | 0 |
| 3 | 63810-0102 | Locator Base | 1 |
| 4 | 63810-0103 | Repair Kit (Not included) | 0 |
| 5 | 63811-6470 | Tool Kit with Locator | 1 |
| 6 | 63811-6475 | Locator (only) | REF |

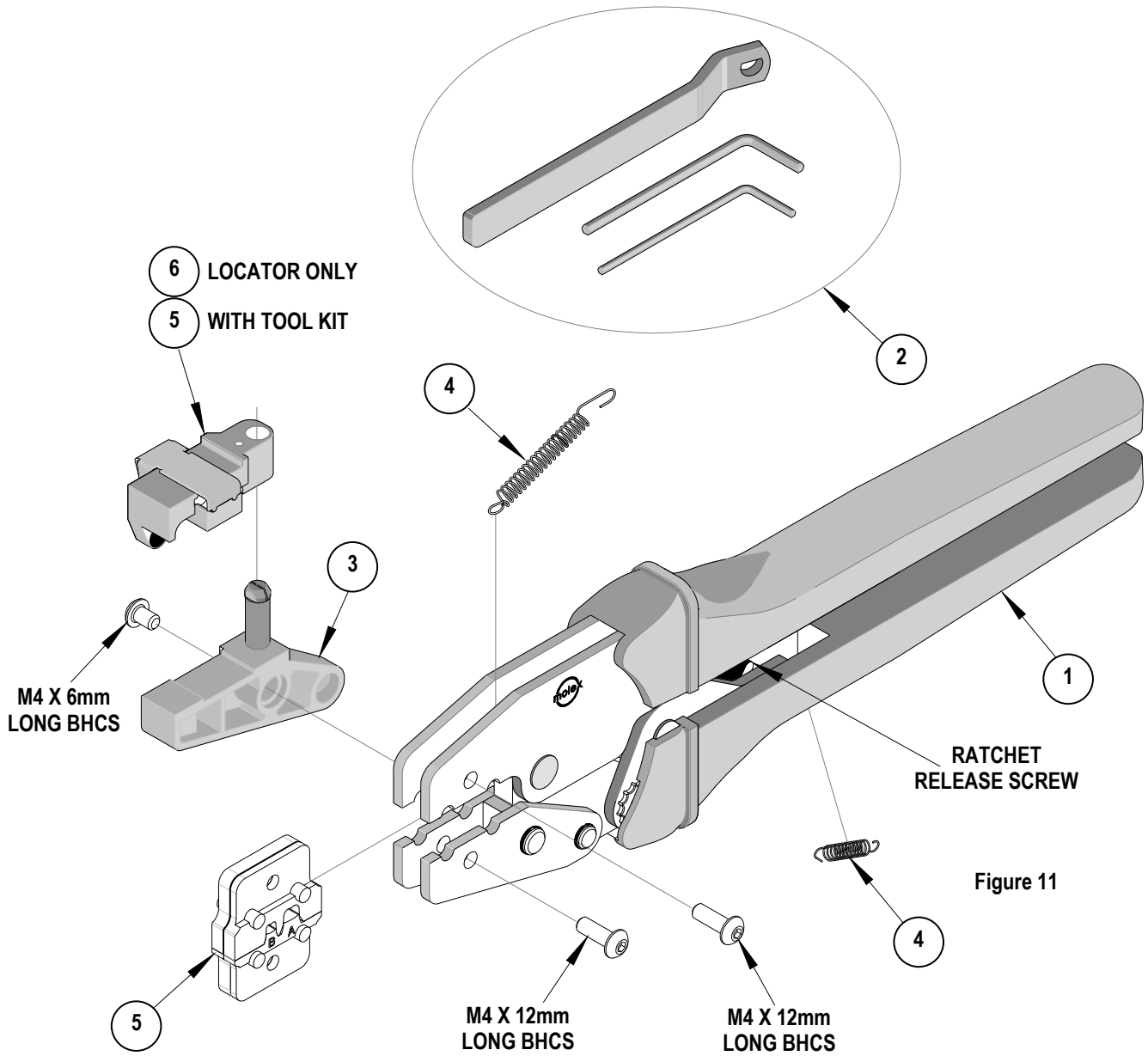

POWER HEAD PARTS LIST

| Item | Order No | Engineering No. | Description | Quantity |
|------|------------|-----------------|------------------|----------|
| 1 | 63816-0300 | 63816-0300 | Power Crimp Head | 1 |
| 2 | 63811-6470 | 63811-6470 | Tool Kit | 1 |

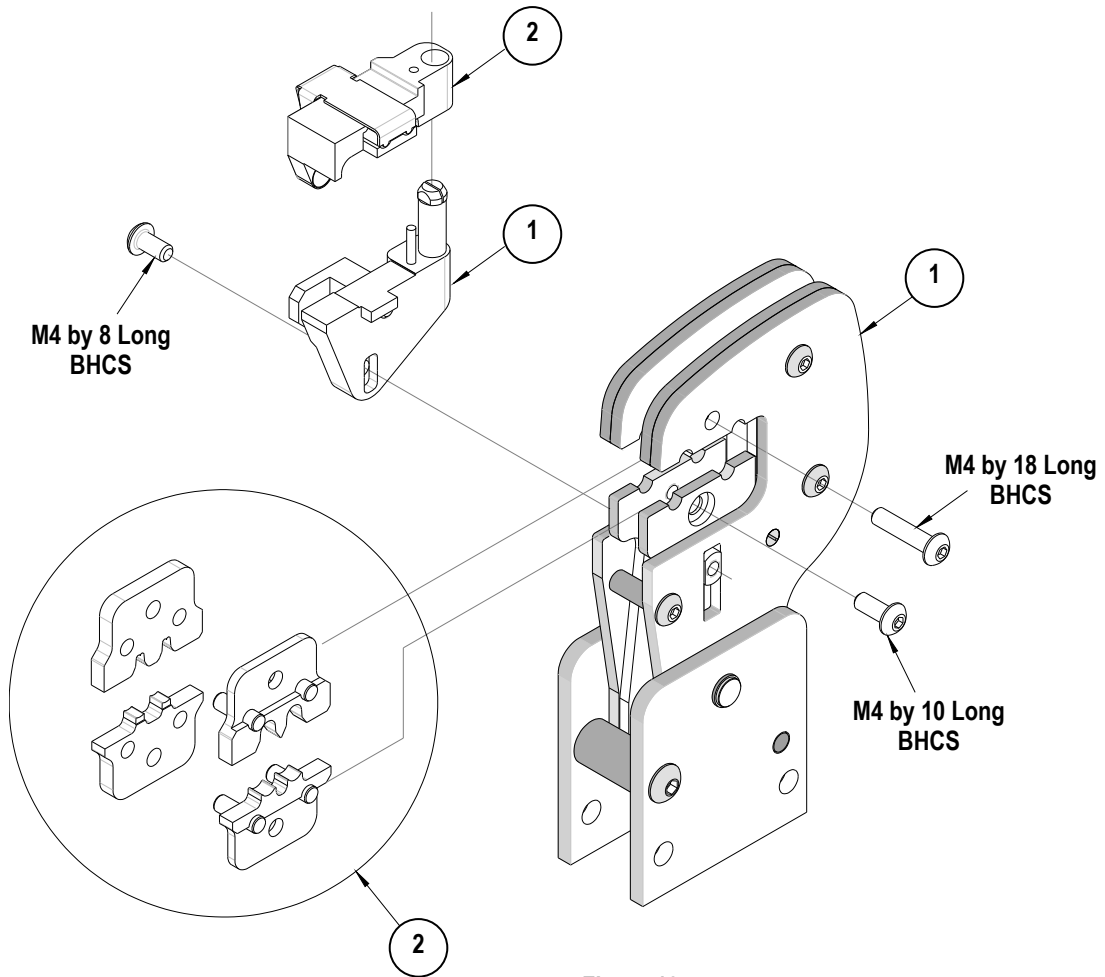

Figure 12

<http://www.molex.com>