

Description

The [XR33052](#), [XR33053](#), [XR33055](#), and [XR33058](#) (XR3305x) are a family of high performance RS-485/RS-422 devices designed for improved performance in noisy industrial environments and increased tolerance to system faults.

The analog bus pins can withstand direct shorts up to ±60V and are protected against ESD events up to ±15kV HBM. An extended ±25V common mode operating range allows for more reliable operation in noisy environments.

The XR3305x receivers include full fail-safe circuitry, guaranteeing a logic-high receiver output when the receiver inputs are open, shorted or undriven. The XR33052/53/55 receiver input impedance is at least 120kΩ (1/10 unit load), allowing more than 320 devices on the bus. The XR33058 receiver input impedance is at least 30KΩ (1/2.5 unit load), allowing more than 80 devices on the bus.

The driver is protected by short circuit detection as well as thermal shutdown and maintains high impedance in shutdown or when powered off.

The DE and \overline{RE} pins include hot swap circuitry to prevent false transitions on the bus during power up or live insertion and can enter a 1nA low current shutdown mode for extreme power savings.

The XR33052/55/58 are half-duplex transceivers offered in an 8-pin NSOIC package and operates at a maximum data rates of 250k, 1M and 20Mbps. The XR33053 is a full-duplex transceiver offered in a 14-pin NSOIC package and operates at a maximum data rate of 1 Mbps.

FEATURES

- 3.0V to 5.5V operation
- ±60V fault tolerance on analog bus pins
- Extended ±25V common mode operation
- Robust ESD protection:
 - ±15kV HBM (bus pins)
 - ±4kV HBM (non-bus pins)
- Enhanced receiver fail-safe protection for open, shorted or terminated but idle data lines
- Hot swap glitch protection on DE and \overline{RE} pins
- Driver short circuit current limit and thermal shutdown for overload protection
- Reduced unit loads allows up to 320 devices on bus
- Industry standard 8-pin and 14-pin NSOIC packages
- -40°C to 85°C and -40°C to 105°C ambient operating temperature ranges

APPLICATIONS

- Industrial control networks
- HVAC networks
- Building and process automation
- Remote utility meter reading
- Energy monitoring and control
- Long or unterminated transmission lines

Ordering Information - [Page 19](#)

Typical Application

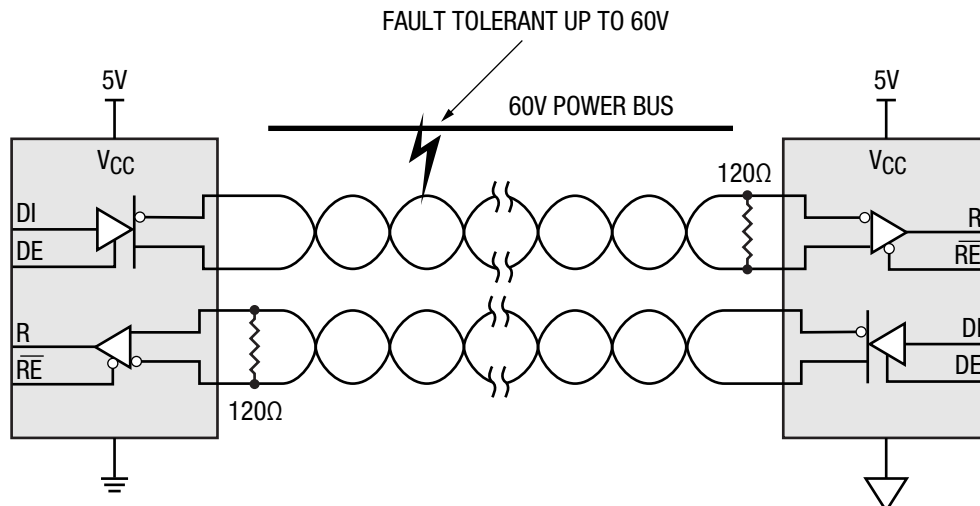

Figure 1. Typical Application

Absolute Maximum Ratings

Stresses beyond the limits listed below may cause permanent damage to the device. Exposure to any Absolute Maximum Rating condition for extended periods may affect device reliability and lifetime.

V_{CC}	-0.3V to 7.0V
Input voltage (DE and DI)	-0.3V to 7.0V
Input voltage (\overline{RE}).....	-0.3V to ($V_{CC} + 0.3V$)
Receiver output voltage (RO).....	-0.3V to ($V_{CC} + 0.3V$)
Driver output voltage (Y, Z, A/Y and B/Z).....	$\pm 60V$
Receiver input voltage (A, B, A/Y and B/Z)	$\pm 60V$
Transient voltage pulse, through 100 Ω	$\pm 100V$
Driver output current.....	$\pm 250mA$
Maximum junction temperature	150°C
Storage temperature	-65°C to 150°C
Lead temperature (soldering 10 seconds).....	300°C

ESD Ratings

HBM - Human Body Model (A, B, Y and Z pins)	$\pm 15kV$
HBM - Human Body Model (all other pins)	$\pm 4kV$

Operating Conditions

Supply voltage range.....	3.0V to 5.5V
Operating temperature range	-40°C to 105°C
Package power dissipation, 8-pin NSOIC θ_{JA}	128.4°C/W
Package power dissipation, 14-pin NSOIC θ_{JA}	86°C/W

Electrical Characteristics

Unless otherwise noted: $V_{CC} = 3.0V$ to $5.5V$, $T_A = T_{MIN}$ to T_{MAX} . Typical values are at $V_{CC} = 5.0V$, $T_A = 25^\circ C$.

Symbol	Parameter	Conditions	Min	Typ	Max	Units
Driver DC Characteristics						
V_{CC}	Supply voltage range		3.0		5.5	V
V_{OD}	Differential driver output, $4.5V \leq V_{CC} \leq 5.5V$	$R_L = 100\Omega$ (RS-422), Figure 3	2		V_{CC}	V
		$R_L = 54\Omega$ (RS-485), Figure 3	1.5		V_{CC}	V
		$-25V \leq V_{CM} \leq 25V$, Figure 4	1.5		V_{CC}	V
	Differential driver output, $3.0V \leq V_{CC} \leq 4.5V$	$R_L = 100\Omega$ (RS-422), Figure 3	0.85		V_{CC}	V
		$R_L = 54\Omega$ (RS-485), Figure 3	0.65		V_{CC}	V
ΔV_{OD}	Change in magnitude of differential output voltage ⁽¹⁾				± 0.2	V
V_{CM}	Driver common-mode output voltage (steady state)	$R_L = 100\Omega$ (RS-422) or $R_L = 54\Omega$ (RS-485), Figure 3	1		3	V
ΔV_{CM}	Change in magnitude of common-mode output voltage ⁽¹⁾				± 0.2	V
V_{IH}	Logic high input thresholds (DI, DE and \overline{RE})	$V_{CC} = 3.3V$	2.0			V
		$V_{CC} = 5.0V$	2.4			V
V_{IL}	Logic low input thresholds (DI, DE and \overline{RE})				0.8	V
V_{HYS}	Input hysteresis (DI, DE and \overline{RE})			100		mV
I_{IN}	Logic input current (DI, DE and \overline{RE})	$0V \leq V_{IN} \leq V_{CC}$, After first transition ⁽²⁾			± 1	μA
I_{INHS}	Logic input current hot swap (DE and \overline{RE})	Until first transition ⁽²⁾		100	± 200	μA
$I_{A, B}$	Input current (A and B)	$V_{CC} = 0V$ or $5.5V$, $V_{OUT} = 12V$, $DE = 0V$, for XR33052/53/55			100	μA
		$V_{CC} = 0V$ or $5.5V$, $V_{OUT} = -7V$, $DE = 0V$, for XR33052/53/55	-80			μA
		$V_{OUT} = 12V$, $DE = 0V$, $V_{CC} = 0V$ or $5.5V$, for XR33058			400	μA
		$V_{OUT} = -7V$, $DE = 0V$, $V_{CC} = 0V$ or $5.5V$, for XR33058	-320			μA
I_{OL}	Output leakage (Y and Z) full-duplex	$V_{OUT} = 12V$, $DE = 0V$, $V_{CC} = 0V$ or $5.5V$			100	μA
		$V_{OUT} = -7V$, $DE = 0V$, $V_{CC} = 0V$ or $5.5V$	-80			μA
I_{OSD}	Driver short-circuit output current	$-60V \leq V_{OUT} \leq 60V$, $DI = 0V$ or V_{CC} , Figure 5			± 250	mA

NOTES:

- Change in magnitude of differential output voltage and change in magnitude of common mode output voltage are the changes in output voltage when DI input changes state.
- The hot swap feature disables the DE and \overline{RE} inputs for the first 10 μs after power is applied. Following this time period, these inputs are weakly pulled to their disabled state (low for DE, high for \overline{RE}) until the first transition, after which they become high impedance inputs.

Electrical Characteristics (Continued)

Unless otherwise noted: $V_{CC} = 3.0V$ to $5.5V$, $T_A = T_{MIN}$ to T_{MAX} . Typical values are at $V_{CC} = 5.0V$, $T_A = 25^\circ C$.

Symbol	Parameter	Conditions	Min	Typ	Max	Units
Driver Thermal Characteristics						
T_{TS}	Thermal shutdown temperature	Junction temperature ⁽¹⁾		175		$^\circ C$
T_{TSH}	Thermal shutdown hysteresis ⁽¹⁾			15		$^\circ C$
Receiver DC Characteristics						
V_{STH}	Receiver differential input signal threshold voltage ($V_A - V_B$)	$-25V \leq V_{OUT} \leq 25V$		± 85	± 200	mV
ΔV_{STH}	Receiver differential input signal hysteresis			170		mV
V_{FSTH-}	Negative going receiver differential input fail-safe threshold voltage ($V_A - V_B$)	$-25V \leq V_{OUT} \leq 25V$	-200	-125	-40	mV
V_{FSTH+}	Positive going receiver differential input fail-safe threshold voltage ($V_A - V_B$)	$-25V \leq V_{OUT} \leq 25V$		-100	-10	mV
ΔV_{FSTH}	Receiver differential input fail-safe hysteresis			25		mV
V_{OH}	Receiver output high voltage (RO)	$I_{OUT} = -4mA$	$V_{CC} - 0.6$			V
V_{OL}	Receiver output low voltage (RO)	$I_{OUT} = 4mA$			0.4	V
I_{OZR}	High-Z receiver output current	$0V \leq V_{OUT} \leq V_{CC}$			± 1	μA
R_{IN}	RX input resistance	$-25V \leq V_{CM} \leq 25V$, XR33052/53/55	120			$k\Omega$
		$-25V \leq V_{CM} \leq 25V$, XR33058	30			$k\Omega$
I_{OSC}	RX output short-circuit current	$0V \leq V_{RO} \leq V_{CC}$			110	mA
Supply Current						
I_{CC}	Supply current	No load, $\overline{RE} = 0V$ or V_{CC} , $DE = V_{CC}$, $DI = 0V$ or V_{CC}			4	mA
I_{SHDN}	Supply current in shutdown mode	$\overline{RE} = V_{CC}$, $DE = 0V$		0.001	1	μA

NOTE:

1. This spec is guaranteed by design and bench characterization.

Electrical Characteristics (Continued)

Driver AC Characteristics - XR33052 (250kbps)

Unless otherwise noted: $V_{CC} = 3.0V$ to $5.5V$, $T_A = T_{MIN}$ to T_{MAX} . Typical values are at $V_{CC} = 5.0V$, $T_A = 25^{\circ}C$.

Symbol	Parameter	Conditions	Min	Typ	Max	Units
t_{DPLH}	Driver propagation delay (low to high)	$C_L = 50pF$, $R_L = 54\Omega$, Figure 7	350		1500	ns
t_{DPHL}	Driver propagation delay (high to low)		350		1600	ns
$ t_{DPLH}-t_{DPHL} $	Differential driver output skew			20	200	ns
t_{DR} , t_{DF}	Driver differential output rise or fall time			400		1500
	Maximum data rate	$1/t_{UI}$, duty cycle 40% to 60%	250			kbps
t_{DZH}	Driver enable to output high	$C_L = 50pF$, $R_L = 500\Omega$, Figure 8		200	2500	ns
t_{DZL}	Driver enable to output low			200	2500	ns
t_{DZH}	Driver disable from output high				250	ns
t_{DLZ}	Driver disable from output low				250	ns
$t_{RZH}(SHDN)$	Driver enable from shutdown to output high	$C_L = 50pF$, $R_L = 500\Omega$, Figure 8			5500	ns
$t_{RZL}(SHDN)$	Driver enable from shutdown to output low				5500	ns
t_{SHDN}	Time to shutdown	Notes 1 and 2	50	200	600	ns

Receiver AC Characteristics -XR33052 (250kbps)

Unless otherwise noted: $V_{CC} = 3.0V$ to $5.5V$, $T_A = T_{MIN}$ to T_{MAX} . Typical values are at $V_{CC} = 5.0V$, $T_A = 25^{\circ}C$.

Symbol	Parameter	Conditions	Min	Typ	Max	Units
t_{RPLH}	Receiver propagation delay (low to high)	$C_L = 15pF$, $V_{ID} = \pm 2V$, V_{ID} rise and fall times < 15ns, Figure 9			200	ns
t_{RPHL}	Receiver propagation delay (high to low)				200	ns
$ t_{RPLH}-t_{RPHL} $	Receiver propagation delay skew				30	ns
	Maximum data rate	$1/t_{UI}$, duty cycle 40% to 60%	250			kbps
t_{RZH}	Receiver enable to output high	$C_L = 15pF$, $R_L = 1k\Omega$, Figure 10			50	ns
t_{RZL}	Receiver enable to output low				50	ns
t_{RHZ}	Receiver disable from output high				50	ns
t_{RLZ}	Receiver disable from output low				50	ns
$t_{RZH}(SHDN)$	Receiver enable from shutdown to output high	$C_L = 15pF$, $R_L = 1k\Omega$, Figure 10			3500	ns
$t_{RZL}(SHDN)$	Receiver enable from shutdown to output low				3500	ns
t_{SHDN}	Time to shutdown	Notes 1 and 2	50	200	600	ns

NOTES:

1. The transceivers are put into shutdown by bringing \overline{RE} high and DE low simultaneously for at least 600ns. If the control inputs are in this state for less than 50ns, the device is guaranteed to not enter shutdown. If the enable inputs are held in this state for at least 600ns, the device is ensured to be in shutdown. Note that the receiver and driver enable times increase significantly when coming out of shutdown.
2. This spec is guaranteed by design and bench characterization.

Electrical Characteristics (Continued)

Driver AC Characteristics - XR33053 and XR33055 (1Mbps)

Unless otherwise noted: $V_{CC} = 3.0V$ to $5.5V$, $T_A = T_{MIN}$ to T_{MAX} . Typical values are at $V_{CC} = 5.0V$, $T_A = 25^{\circ}C$.

Symbol	Parameter	Conditions	Min	Typ	Max	Units	
t_{DPLH}	Driver propagation delay (low to high)	$C_L = 50pF$, $R_L = 54\Omega$, Figure 7		150	500	ns	
t_{DPHL}	Driver propagation delay (high to low)			150	500	ns	
$ t_{DPLH}-t_{DPHL} $	Differential driver output skew				5	50	ns
t_{DR} , t_{DF}	Driver differential output rise or fall time			100	200	300	ns
	Maximum data rate	$1/t_{UI}$, duty cycle 40% to 60%	1			Mbps	
t_{DZH}	Driver enable to output high	$C_L = 50pF$, $R_L = 500\Omega$, Figure 8		1000	2500	ns	
t_{DZL}	Driver enable to output low				1000	2500	ns
t_{DZH}	Driver disable from output high					250	ns
t_{DLZ}	Driver disable from output low					250	ns
$t_{DZH}(SHDN)$	Driver enable from shutdown to output high	$C_L = 50pF$, $R_L = 500\Omega$, Figure 8		2500	4500	ns	
$t_{DZL}(SHDN)$	Driver enable from shutdown to output low				2500	4500	ns
t_{SHDN}	Time to shutdown	Notes 1 and 2	50	200	600	ns	

Receiver AC Characteristics - XR33053 and XR33055 (1Mbps)

Unless otherwise noted: $V_{CC} = 3.0V$ to $5.5V$, $T_A = T_{MIN}$ to T_{MAX} . Typical values are at $V_{CC} = 5.0V$, $T_A = 25^{\circ}C$.

Symbol	Parameter	Conditions	Min	Typ	Max	Units
t_{RPLH}	Receiver propagation delay (low to high)	$C_L = 15pF$, $V_{ID} = \pm 2V$, V_{ID} rise and fall times < 15ns, Figure 9			200	ns
t_{RPHL}	Receiver propagation delay (high to low)				200	ns
$ t_{RPLH}-t_{RPHL} $	Receiver propagation delay skew					30
	Maximum data rate	$1/t_{UI}$, duty cycle 40% to 60%	1			Mbps
t_{RZH}	Receiver enable to output high	$C_L = 15pF$, $R_L = 1k\Omega$, Figure 10			50	ns
t_{RZL}	Receiver enable to output low				50	ns
t_{RHZ}	Receiver disable from output high				50	ns
t_{RLZ}	Receiver disable from output low				50	ns
$t_{RZH}(SHDN)$	Receiver enable from shutdown to output high	$C_L = 15pF$, $R_L = 1k\Omega$, Figure 10			3500	ns
$t_{RZL}(SHDN)$	Receiver enable from shutdown to output low				3500	ns
t_{SHDN}	Time to shutdown	Notes 1 and 2	50	200	600	ns

NOTES:

1. The transceivers are put into shutdown by bringing \overline{RE} high and DE low simultaneously for at least 600ns. If the control inputs are in this state for less than 50ns, the device is guaranteed to not enter shutdown. If the enable inputs are held in this state for at least 600ns, the device is ensured to be in shutdown. Note that the receiver and driver enable times increase significantly when coming out of shutdown.
2. This spec is guaranteed by design and bench characterization.

Electrical Characteristics (Continued)

Driver AC Characteristics - XR33058 (20Mbps)

Unless otherwise noted: $V_{CC} = 3.0V$ to $5.5V$, $T_A = T_{MIN}$ to T_{MAX} . Typical values are at $V_{CC} = 5.0V$, $T_A = 25^\circ C$.

Symbol	Parameter	Conditions	Min	Typ	Max	Units
t_{DPLH}	Driver propagation delay (low to high)	$C_L = 50pF$, $R_L = 54\Omega$, Figure 7			25	ns
t_{DPHL}	Driver propagation delay (high to low)				25	ns
$ t_{DPLH} - t_{DPHL} $	Differential driver output skew				5	ns
t_{DR} , t_{DF}	Driver differential output rise or fall time				15	ns
	Maximum data rate	$1/t_{UI}$, duty cycle 40% to 60%	20			Mbps
t_{DZH}	Driver enable to output high	$C_L = 50pF$, $R_L = 500\Omega$, Figure 8			60	ns
t_{DZL}	Driver enable to output low				60	ns
t_{DZH}	Driver disable from output high				250	ns
t_{DLZ}	Driver disable from output low				250	ns
$t_{DZH}(SHDN)$	Driver enable from shutdown to output high	$C_L = 50pF$, $R_L = 500\Omega$, Figure 8			2200	ns
$t_{DZL}(SHDN)$	Driver enable from shutdown to output low				2200	ns
t_{SHDN}	Time to shutdown	Notes 1 and 2	50	200	600	ns

Receiver AC Characteristics - XR33058 (20Mbps)

Unless otherwise noted: $V_{CC} = 3.0V$ to $5.5V$, $T_A = T_{MIN}$ to T_{MAX} . Typical values are at $V_{CC} = 5.0V$, $T_A = 25^\circ C$.

Symbol	Parameter	Conditions	Min	Typ	Max	Units
t_{RPLH}	Receiver propagation delay (low to high)	$C_L = 15pF$, $V_{ID} = \pm 2V$, V_{ID} rise and fall times $< 15ns$, Figure 9			60	ns
t_{RPHL}	Receiver propagation delay (high to low)				60	ns
$ t_{RPLH} - t_{RPHL} $	Receiver propagation delay skew				5	ns
	Maximum data rate	$1/t_{UI}$, duty cycle 40% to 60%	20			Mbps
t_{RZH}	Receiver enable to output high	$C_L = 15pF$, $R_L = 1k\Omega$, Figure 10			50	ns
t_{RZL}	Receiver enable to output low				50	ns
t_{RZH}	Receiver disable from output high				50	ns
t_{RLZ}	Receiver disable from output low				50	ns
$t_{RZH}(SHDN)$	Receiver enable from shutdown to output high	$C_L = 15pF$, $R_L = 1k\Omega$, Figure 10			2200	ns
$t_{RZL}(SHDN)$	Receiver enable from shutdown to output low				2200	ns
t_{SHDN}	Time to shutdown	Notes 1 and 2	50	200	600	ns

NOTES:

- The transceivers are put into shutdown by bringing \overline{RE} high and DE low simultaneously for at least 600ns. If the control inputs are in this state for less than 50ns, the device is guaranteed to not enter shutdown. If the enable inputs are held in this state for at least 600ns, the device is ensured to be in shutdown. Note that the receiver and driver enable times increase significantly when coming out of shutdown.
- This spec is guaranteed by design and bench characterization.

Pin Configuration

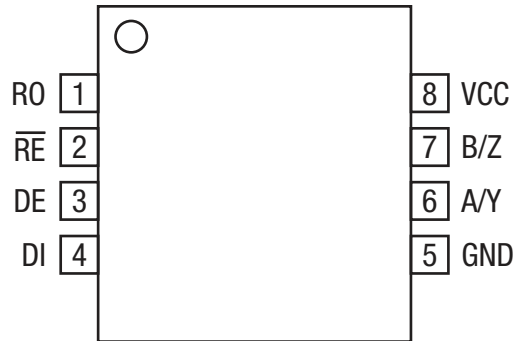

XR33052, XR33055 and XR33058 Half-duplex

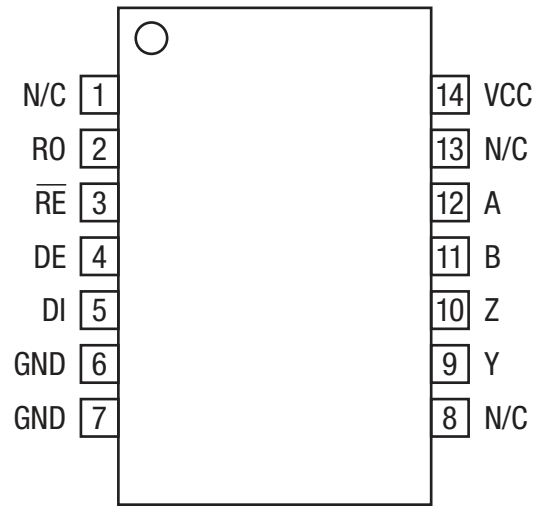

XR33053 Full-duplex

Pin Functions

Pin Number		Pin Name	Type	Description
Half-duplex XR33052 XR33055 XR33058	Full-duplex XR33053			
1	2	RO	Output	Receiver output. When \overline{RE} is low and if $(A-B) \geq 200\text{mV}$, RO is high. If $(A-B) \leq -200\text{mV}$, RO is low. If inputs are left floating, shorted together or terminated and undriven for more than $2\mu\text{s}$, the output is high.
2	3	\overline{RE}	Input	Receiver output enable (hot swap). When \overline{RE} is low, RO is enabled. When \overline{RE} is high, RO is high impedance, \overline{RE} should be high and DE should be low to enter shutdown mode.
3	4	DE	Input	Driver output enable (hot swap). When DE is high, outputs are enabled. When DE is low, outputs are high impedance, DE should be low and \overline{RE} should be high to enter shutdown mode.
4	5	DI	Input	Driver input. With DE high, a low level on DI forces non-inverting output low and inverting output high. Similarly, a high level on DI forces non-inverting output high and inverting output low.
5	6, 7	GND	Power	Ground.
8	14	VCC	Power	3.0V to 5.5V power supply input, bypass to ground with $0.1\mu\text{F}$ capacitor.
	12	A	Input	Non-inverting receiver input.
	11	B	Input	Inverting receiver input.
	9	Y	Output	Non-inverting driver output.
	10	Z	Output	Inverting driver output.
6		A/Y	I/O	Non-inverting receiver input and non-inverting driver output.
7		B/Z	I/O	Inverting receiver input and inverting driver output.
	1, 8, 13	N/C	-	Not connected.

Pin Functions (Continued)

Transmitting				
Inputs			Outputs	
\overline{RE}	DE	DI	Y	Z
X	1	1	1	0
X	1	0	0	1
0	0	X	High-Z	
1	0	X	High-Z (shutdown)	

Receiving			
Inputs			Output
\overline{RE}	DE	$V_A - V_B$	RO
0	X	$\geq 200mV$	1
0	X	$\leq -200mV$	0
0	X	Open/shorted/idle	1
1	1	X	High-Z
1	0	X	High-Z (shutdown)

Applications Information

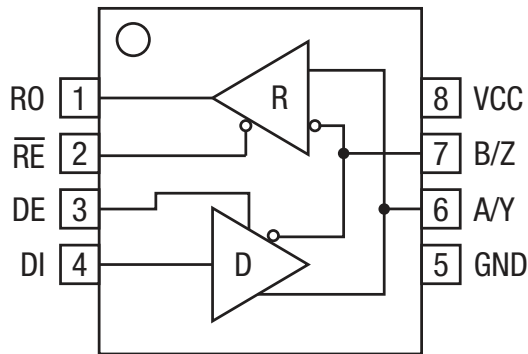

XR33052, XR33055 and XR33058

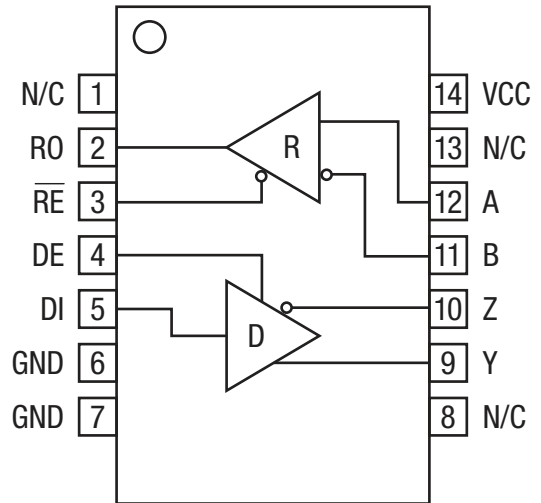

XR33053

Figure 2. XR33052, XR33055 and XR33058 Half-duplex and XR33053 Full-duplex

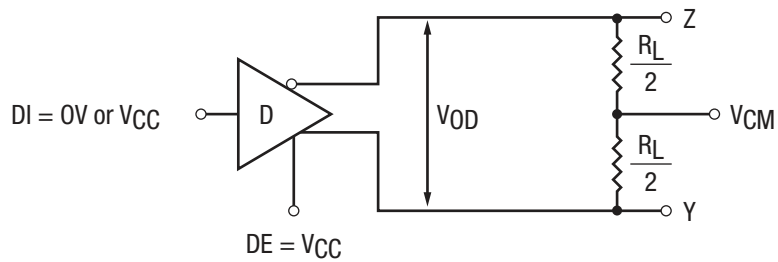

Figure 3. Differential Driver Output Voltage

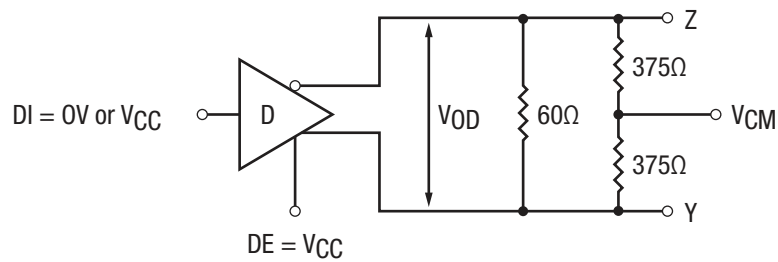

Figure 4. Differential Driver Output Voltage Over Common Mode

Applications Information (Continued)

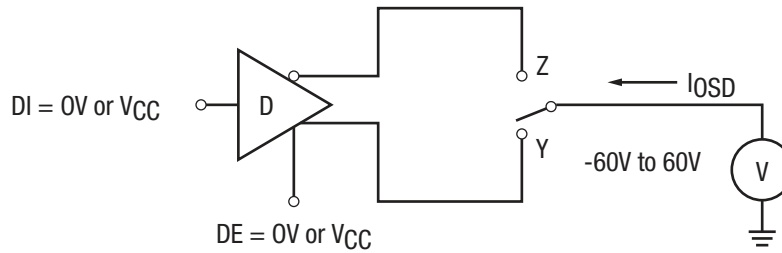

Figure 5. Driver Output Short Circuit Current

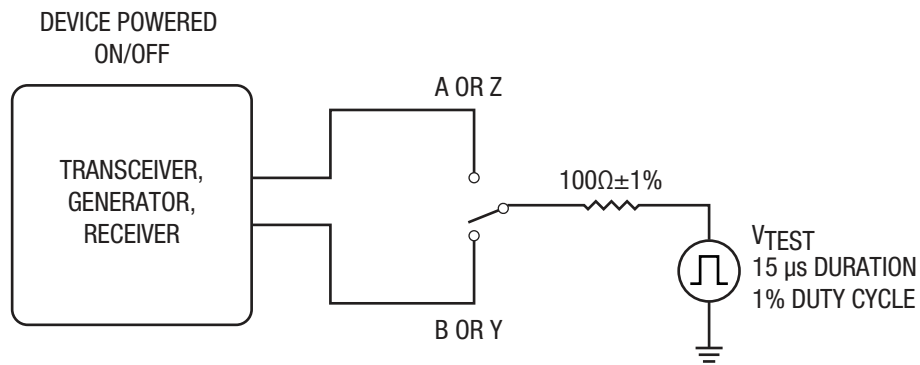

Figure 6. Transient Overvoltage Test Circuit

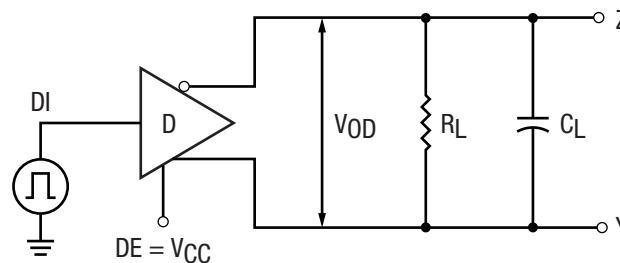
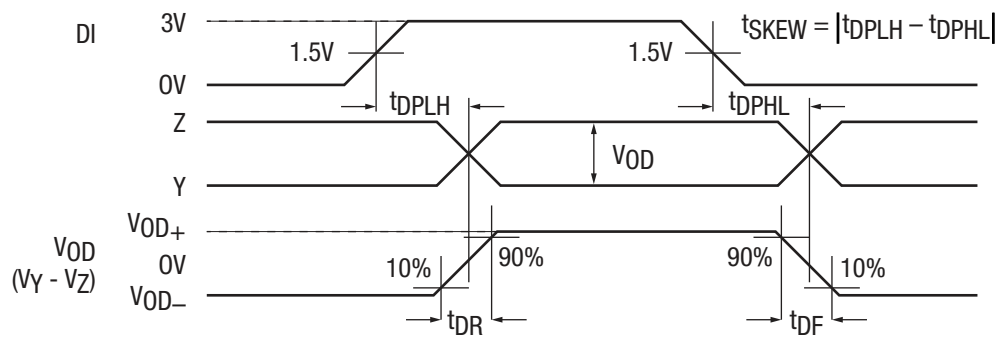

Figure 7. Driver Propagation Delay Test Circuit and Timing Diagram

Applications Information (Continued)

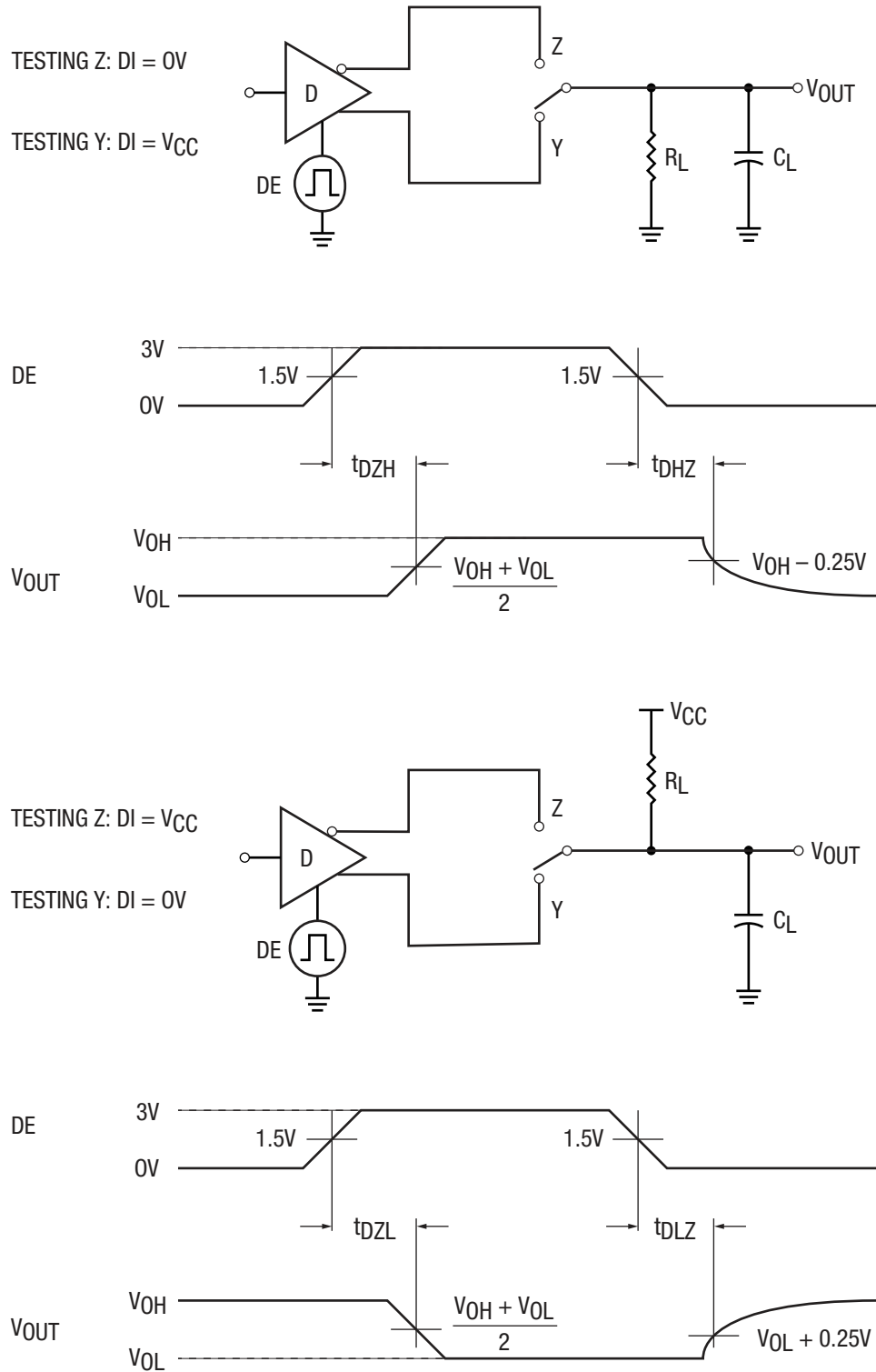

Figure 8. Driver Enable and Disable Timing Test Circuits and Timing Diagrams

Applications Information (Continued)

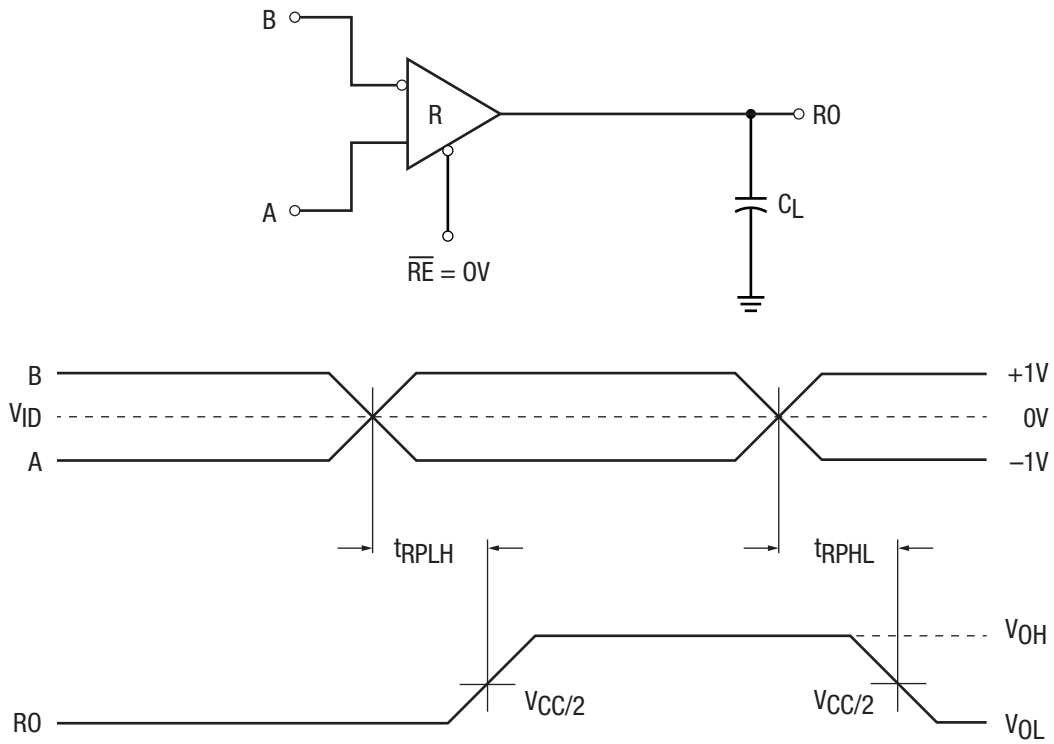

Figure 9. Receiver Propagation Delay Test Circuit and Timing Diagram

Applications Information (Continued)

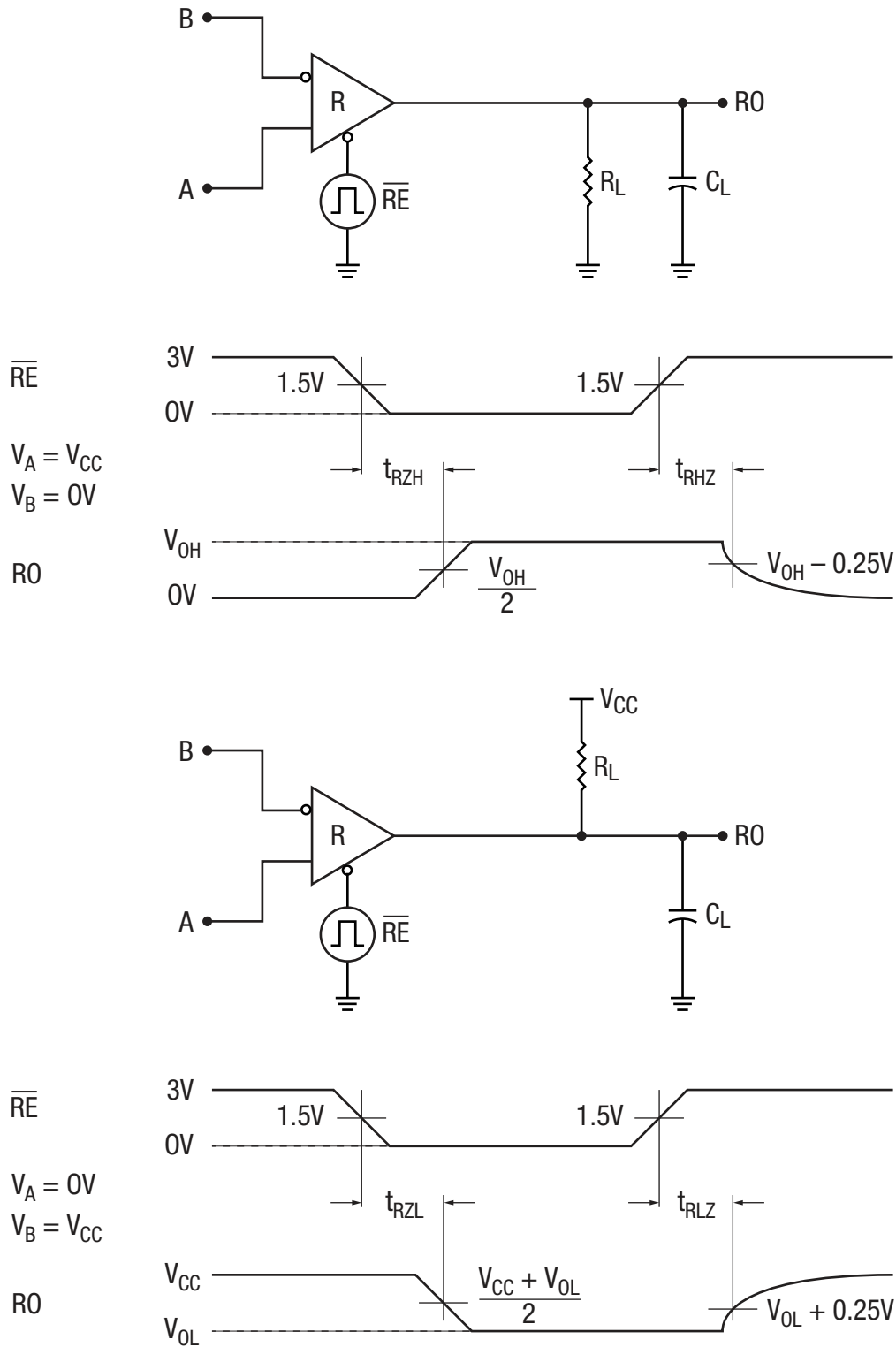

Figure 10. Receiver Enable and Disable Test Circuits and Timing Diagrams

Applications Information (Continued)

The XR3305x RS-485/RS-422 devices are part of MaxLinear's high performance serial interface product line. The analog bus pins can survive direct shorts up to $\pm 60\text{V}$ and are protected against ESD events up to $\pm 15\text{kV}$.

Enhanced Failsafe

Ordinary RS-485 differential receivers will be in an indeterminate state whenever the data bus is not being actively driven. The enhanced failsafe feature of the XR3305x guarantees a logic-high receiver output when the receiver inputs are open, shorted or when they are connected to a terminated transmission line with all drivers disabled. In a terminated bus with all transmitters disabled, the receivers' differential input voltage is pulled to 0V by the termination. The XR3305x interprets 0V differential as a logic high with a minimum 50mV noise margin while maintaining compliance with the RS-485 standard of $\pm 200\text{mV}$. Although the XR3305x does not need failsafe biasing resistors, it can operate without issue if biasing is used.

Hot Swap Capability

When V_{CC} is first applied, the XR3305x holds the driver enable and receiver enable inactive for approximately 10 μs . During power ramp-up, other system ICs may drive unpredictable values or tristated lines may be influenced by stray capacitance. The hot swap feature prevents the XR3305x from driving any output signal until power has stabilized. After the initial 10 μs , the driver and receiver enable pins are weakly pulled to their disabled states (low for DE, high for $\overline{\text{RE}}$) until the first transition. After the first transition, the DE and $\overline{\text{RE}}$ pins operate as high impedance inputs.

If circuit boards are inserted into an energized backplane (commonly called "live insertion" or "hot swap") power may suddenly be applied to all circuits. Without the hot swap capability, this situation could improperly enable the transceiver's driver or receiver, driving invalid data onto shared buses and possibly causing driver contention or device damage.

Driver Output Protection

Two mechanisms prevent excessive output current and power dissipation caused by faults or by bus contention. First, a driver current limit on the output stage provides immediate protection against short circuits over the whole common-mode voltage range. Second, a thermal shutdown circuit forces the driver outputs into a high-impedance state if junction temperature becomes excessive.

Line Length

The RS-485/RS-422 standard covers line lengths up to 4000ft. Maximum achievable line length is a function of signal attenuation and noise. Termination prevents signal reflections by eliminating the impedance mismatches on a transmission line. Line termination is generally used if

rise and fall times are shorter than the round-trip signal propagation time. Higher output drivers may allow longer cables to be used.

$\pm 15\text{kV}$ HBM ESD Protection (Unpowered Part)

ESD protection structures are incorporated on all pins to protect against electrostatic discharges encountered during handling and assembly. The driver outputs and receiver inputs of the XR3305x family have extra protection against static electricity. MaxLinear uses state-of-the-art structures to protect these pins against ESD damage:

- $\pm 15\text{kV}$ HBM for bus pins to GND
- $\pm 4\text{kV}$ HBM for all other pins

ESD Test Conditions

ESD performance depends on a variety of conditions. Contact MaxLinear for a reliability report that documents test setup, methodology and results.

Maximum Number of Transceivers on the Bus

The standard RS-485 receiver input impedance is 12k Ω (1 unit load). A standard driver can drive up to 32 unit loads. The XR33052/53/55 transceiver has a 1/10th unit load receiver input impedance of 120k Ω , allowing up to 320 transceivers to be connected in parallel on a communication line. The XR33058 receiver input impedance is a least 30K Ω (1/2.5 unit load), allowing more than 80 devices on the bus. Any combination of the XR3305x's and other RS-485 transceivers up to a total of 32 unit loads may be connected to the line.

Low Power Shutdown Mode

Low power shutdown mode is initiated by bringing both $\overline{\text{RE}}$ high and DE low simultaneously. While in shutdown devices draw less than 1 μA of supply current. DE and $\overline{\text{RE}}$ may be tied together and driven by a single control signal. Devices are guaranteed not to enter shutdown if $\overline{\text{RE}}$ is high and DE is low for less than 50ns. If the inputs are in this state for at least 600ns, the parts will enter shutdown.

Enable times t_{ZH} and t_{ZL} apply when the part is not in low power shutdown state. Enable times $t_{ZH(\text{SHDN})}$ and $t_{ZL(\text{SHDN})}$ apply when the parts are shutdown. The driver and receiver take longer to become enabled from low power shutdown $t_{ZH(\text{SHDN})}$ and $t_{ZL(\text{SHDN})}$ than from driver or receiver disable mode (t_{ZH} and t_{ZL}).

Applications Information (Continued)**Product Selector Guide**

Part Number	Operation	Data Rate	Shutdown	Receiver/Driver Enable	Nodes On Bus	Footprint
XR33052	Half-duplex	250kbps	Yes	Yes/Yes	320	8-NSOIC
XR33053	Full-duplex	1Mbps				14-NSOIC
XR33055	Half-duplex					8-NSOIC
XR33058	Half-duplex	20Mbps			80	

Mechanical Dimensions

NSOIC-8

Top View

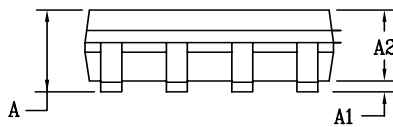
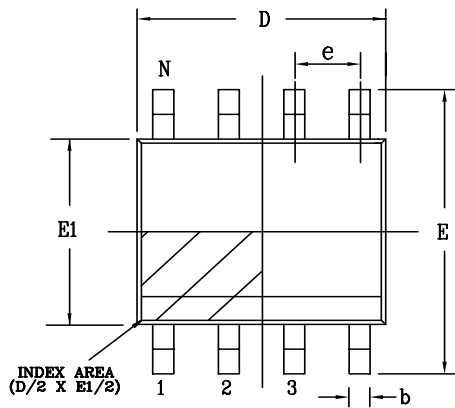

Side View

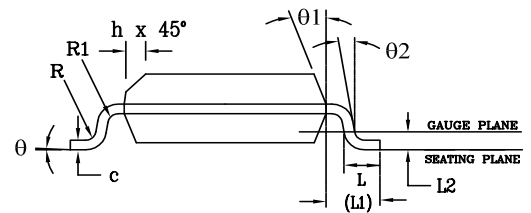

Front View

PACKAGE OUTLINE NSOIC .150" BODY JEDEC MS-012 VARIATION AA						
SYMBOLS	COMMON DIMENSIONS IN MM (Control Unit)			COMMON DIMENSIONS IN INCH (Reference Unit)		
	MIN	NOM	MAX	MIN	NOM	MAX
A	1.35	—	1.75	0.053	—	0.069
A1	0.10	—	0.25	0.004	—	0.010
A2	1.25	—	1.65	0.049	—	0.065
b	0.31	—	0.51	0.012	—	0.020
c	0.17	—	0.25	0.007	—	0.010
E	6.00 BSC			0.236 BSC		
E1	3.90 BSC			0.154 BSC		
e	1.27 BSC			0.050 BSC		
h	0.25	—	0.50	0.010	—	0.020
L	0.40	—	1.27	0.016	—	0.050
L1	1.04 REF			0.041 REF		
L2	0.25 BSC			0.010 BSC		
R	0.07	—	—	0.003	—	—
R1	0.07	—	—	0.003	—	—
q	0°	—	8°	0°	—	8°
q1	5°	—	15°	5°	—	15°
q2	0°	—	—	0°	—	—
D	4.90 BSC			0.193 BSC		
N	8			8		

Drawing No: POD-0000108
Revision: A

Mechanical Dimensions

NSOIC-14

Top View

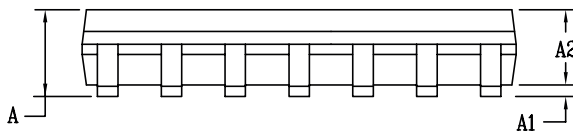
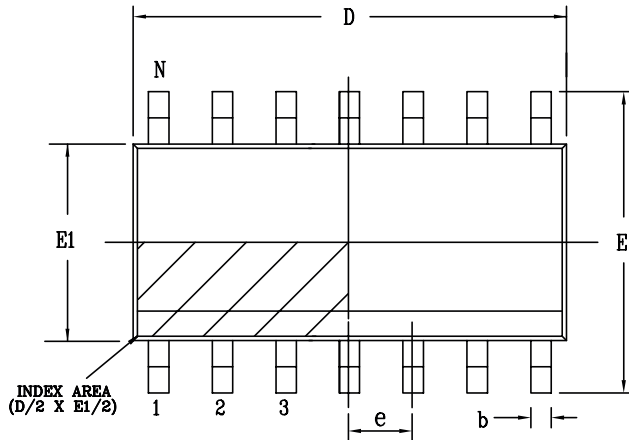

Side View

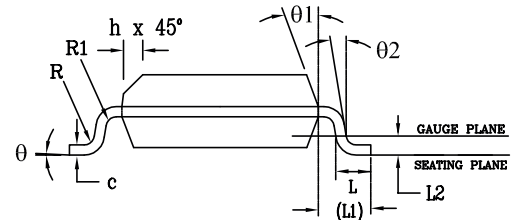

Front View

PACKAGE OUTLINE NSOIC .150" BODY JEDEC MS-012 VARIATION AB						
SYMBOLS	COMMON DIMENSIONS IN MM (Control Unit)			COMMON DIMENSIONS IN INCH (Reference Unit)		
	MIN	NOM	MAX	MIN	NOM	MAX
A	1.35	—	1.75	0.053	—	0.069
A1	0.10	—	0.25	0.004	—	0.010
A2	1.25	—	1.65	0.049	—	0.065
b	0.31	—	0.51	0.012	—	0.020
c	0.17	—	0.25	0.007	—	0.010
E	6.00 BSC			0.236 BSC		
E1	3.90 BSC			0.154 BSC		
e	1.27 BSC			0.050 BSC		
h	0.25	—	0.50	0.010	—	0.020
L	0.40	—	1.27	0.016	—	0.050
L1	1.04 REF			0.041 REF		
L2	0.25 BSC			0.010 BSC		
R	0.07	—	—	0.003	—	—
R1	0.07	—	—	0.003	—	—
q1	0°	—	8°	0°	—	8°
q1	5°	—	15°	5°	—	15°
q2	0°	—	—	0°	—	—
D	8.65 BSC			0.341 BSC		
N	14					

Drawing No: POD-00000109

Revision: A

Ordering Information⁽¹⁾

Part Number	Operating Temperature Range	Lead-Free	Package	Packaging Method
XR33052ID-F	-40°C to 85°C	Yes ⁽²⁾	8-pin SOIC	Tube
XR33052IDTR-F				Reel
XR33052HD-F	-40°C to 105°C			Tube
XR33052HDTR-F				Reel
XR33053ID-F	-40°C to 85°C		14-pin SOIC	Tube
XR33053IDTR-F				Reel
XR33053HD-F	-40°C to 105°C			Tube
XR33053HDTR-F				Reel
XR33055ID-F	-40°C to 85°C		8-pin SOIC	Tube
XR33055IDTR-F				Reel
XR33055HD-F	-40°C to 105°C			Tube
XR33055HDTR-F				Reel
XR33058IDTR-F	-40°C to 85°C			Reel
XR33058HD-F				Tube
XR33058HDTR-F	-40°C to 105°C			Reel
XR33052IDEVB XR33052HDEVB XR33053IDEVB XR33053HDEVB XR33055IDEVB XR33055HDEVB XR33058IDEVB XR33058HDEVB	Evaluation Boards			

NOTE:

1. Refer to www.exar.com/XR33052, www.exar.com/XR33053, www.exar.com/XR33055, www.exar.com/XR33058 for most up-to-date Ordering Information.
2. Visit www.exar.com for additional information on Environmental Rating.

Revision History

Revision	Date	Description
1A	Jan 2016	Initial release of XR33053
2A	July 2016	Add XR33052, XR33055 and XR33058
2B	Feb 2017	Added missing connection from pin 2 to receiver, page 10
2C	Feb 2018	Update to MaxLinear logo. Updated format and Ordering information. Moved ESD ratings to page 2.



Corporate Headquarters:

5966 La Place Court
Suite 100
Carlsbad, CA 92008
Tel.: +1 (760) 692-0711
Fax: +1 (760) 444-8598
www.maxlinear.com

High Performance Analog:

1060 Rincon Circle
San Jose, CA 95131
Tel.: +1 (669) 265-6100
Fax: +1 (669) 265-6101
Email: serialtechsupport@exar.com
www.exar.com

The content of this document is furnished for informational use only, is subject to change without notice, and should not be construed as a commitment by MaxLinear, Inc.. MaxLinear, Inc. assumes no responsibility or liability for any errors or inaccuracies that may appear in the informational content contained in this guide. Complying with all applicable copyright laws is the responsibility of the user. Without limiting the rights under copyright, no part of this document may be reproduced into, stored in, or introduced into a retrieval system, or transmitted in any form or by any means (electronic, mechanical, photocopying, recording, or otherwise), or for any purpose, without the express written permission of MaxLinear, Inc.

MaxLinear, Inc. does not recommend the use of any of its products in life support applications where the failure or malfunction of the product can reasonably be expected to cause failure of the life support system or to significantly affect its safety or effectiveness. Products are not authorized for use in such applications unless MaxLinear, Inc. receives, in writing, assurances to its satisfaction that: (a) the risk of injury or damage has been minimized; (b) the user assumes all such risks; (c) potential liability of MaxLinear, Inc. is adequately protected under the circumstances.

MaxLinear, Inc. may have patents, patent applications, trademarks, copyrights, or other intellectual property rights covering subject matter in this document. Except as expressly provided in any written license agreement from MaxLinear, Inc., the furnishing of this document does not give you any license to these patents, trademarks, copyrights, or other intellectual property.

Company and product names may be registered trademarks or trademarks of the respective owners with which they are associated.

© 2016 - 2018 MaxLinear, Inc. All rights reserved