

Switching Power Supply

200 WATT / SINGLE OUTPUT

KEY FEATURES:

- 200 Watts output Power
- 12 VDC Single Output
- Open Frame Package measuring only 3" x 5" x 1.24"
- High Density in excess of 10W/in³
- 90% Efficiency typical
- High Reliability in excess of 300,000 Hours
- International Safety Approvals
- Class B Radiated and Conducted Emissions



MODEL	Output Voltage (V)	Regulation	Maximum Current (A)	Ripple/Noise (mVp-p)	Standby (Vsb)
ARFL-2011-12S	+12.0	+/- 1%	16.7	120	N/A

INPUT SPECIFICATIONS	
Input Voltage	90 – 264 VAC
Input Frequency	47 – 63 Hz
Input Current	Maximum 3A @ 100 VAC
Inrush Current	50A @ 230 VAC
Input Protection	Fuse
Leakage Current	Maximum 1 mA
Power Factor Correction	Active PFC to meet or exceed EN61000-3-2

OUTPUT SPECIFICATIONS	
Setpoint Accuracy	+/- 1%
Total Output Power	200W
Hold-up Time	16ms @ 75% load
Efficiency	90% typical
Minimum Load	No minimum load
Isolation (HiPot)	1500 VAC Input to Ground

PROTECTION	
Overvoltage	Latch-mode (Cycle AC input)
Overpower	Latch-mode (Cycle AC input)
Short Circuit	Latch-mode (Cycle AC input)
Thermal (option)	Auto-recovery / latch off

ENVIRONMENT SPECIFICATIONS	
Operating Temperature	0 °C to +70 °C Derate linearly above 50 °C to 50% load @ 70 °C
Storage Temperature	-40 °C to +85 °C
Forced Air Cooling	15CFM from AC to DC side
MTBF	300 kHrs to MIL-HDBK-217F at 25 °C
Shock	Storage: 30G , 11ms, 1/2 sine wave pulse, 6 axis Operation: 5G , 11ms, 1/2 sine wave pulse, 6 axis
Vibration	2G rms, 5Hz to 500kHz, 3 axis



COMPLIANCE

EMI	FCC Class B / EN55022 Class B under all rated input and load conditions
Electrostatic Discharge	EN61000-4-2: Contact Discharge- Contact discharge in 2kV increments to 6kV for metallic surfaces including connector bodies. 10 discharges pretest point at each voltage: 5 positive polarity and 5 negative polarity. Air discharge – Air discharge in 2kV increments to 8kV for scams and non-metallic user accessible surfaces. 10 discharges pretest point at each voltage: 5 positive polarity and 5 negative polarity.
Radiated Susceptibility	EN61000-4-3: Electromagnetic Field Strength 3V/m
EFT / Bursts	EN61000-4-4: Direct Coupling Line to Ground Reference Plane: 1kV increments up to 2kv for a minimum of 1 min. at each voltage. Direct Coupling Neutral to Ground Reference Plane: 1kV increments up to 2kV for a minimum of 1 min. at each voltage. Direct Coupling Ground to Ground Reference Plane: 1kV increments up to 2kV for a minimum of 1 min. at each voltage
Surges	EN61000-4-5: The peak value of the bi-directional surge waveform shall be 2kV for common mode and 1kV for differential modes of transient surge injection. No unsafe operation or no user noticeable degradation is allowed under any condition.
Conducted Immunity	EN61000-4-6: 0.15~800MHz, 10V, 80% AM
Voltage Dips	EN61000-4-10: 95% Dip & 10ms, 30% Dip & 500mS
Voltage Interruptions	EN61000-4-11, 95% reduction, 5s
Fluctuations & Flicker	EN61000-3-3
Harmonic Distortion	EN61000-3-2 Class D
Safety Certifications	cTUVus UL60950-1, CB Report IEC 60950-1

Typical Outline Drawing:

(REFER TO PRODUCT MECHANICAL DRAWING FOR COMPLETE INFORMATION)

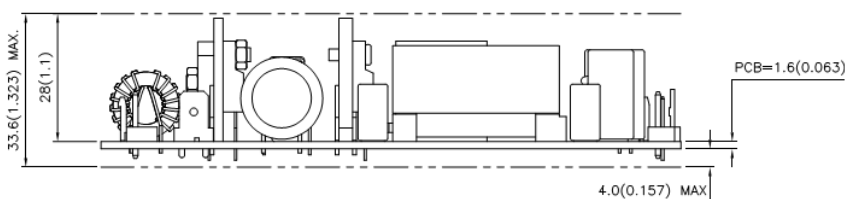
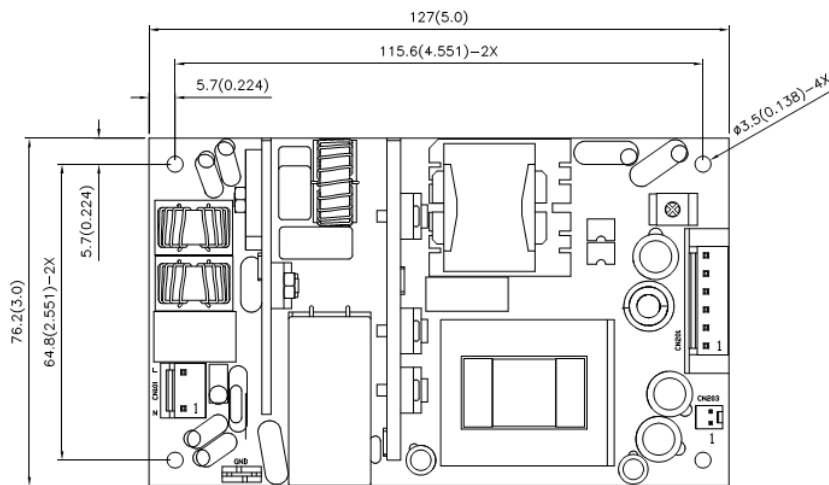

CONNECTORS

CN201	
Pin	Signal
1	GND
2	GND
3	GND
4	12V
5	12V
6	12V

CN203 (FAN)	
Pin	Signal
1	GND
2	12V

DERATING

