

April 1995

30A, 700V - 1000V Hyperfast Diodes

Features

- Hyperfast with Soft Recovery <65ns
- Operating Temperature +175°C
- Reverse Voltage Up To 1000V
- Avalanche Energy Rated
- Planar Construction

Applications

- Switching Power Supplies
- Power Switching Circuits
- General Purpose

Description

RHRP3070, RHRP3080, RHRP3090 and RHRP30100 (TA49064) are hyperfast diodes with soft recovery characteristics ($t_{RR} < 65ns$). They have half the recovery time of ultrafast diodes and are silicon nitride passivated ion-implanted epitaxial planar construction.

These devices are intended for use as freewheeling/clamping diodes and rectifiers in a variety of switching power supplies and other power switching applications. Their low stored charge and hyperfast soft recovery minimize ringing and electrical noise in many power switching circuits reducing power loss in the switching transistors.

PACKAGING AVAILABILITY

PART NUMBER	PACKAGE	BRAND
RHRP3070	TO-220AC	RHRP3070
RHRP3080	TO-220AC	RHRP3080
RHRP3090	TO-220AC	RHRP3090
RHRP30100	TO-220AC	RHR30100

NOTE: When ordering, use the entire part number.

Package

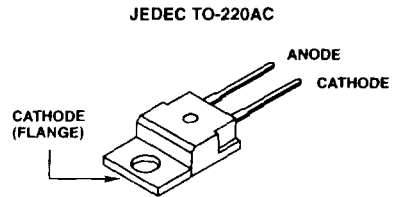

Symbol



Absolute Maximum Ratings $T_C = +25^\circ C$, Unless Otherwise Specified

	RHRP3070	RHRP3080	RHRP3090	RHRP30100	UNITS
Peak Repetitive Reverse Voltage V_{RRM}	700	800	900	1000	V
Working Peak Reverse Voltage V_{RWM}	700	800	900	1000	V
DC Blocking Voltage V_R	700	800	900	1000	V
Average Rectified Forward Current $I_{F(AV)}$ ($T_C = +95^\circ C$)	30	30	30	30	A
Repetitive Peak Surge Current I_{FSM} (Square Wave, 20kHz)	70	70	70	70	A
Nonrepetitive Peak Surge Current I_{FSM} (Halfwave, 1 Phase, 60Hz)	325	325	325	325	A
Maximum Power Dissipation P_D	125	125	125	125	W
Avalanche Energy (See Figures 10 and 11) E_{AVL}	20	20	20	20	mJ
Operating and Storage Temperature T_{STG}, T_J	-65 to +175	-65 to +175	-65 to +175	-65 to +175	$^\circ C$

Specifications RHRP3070, RHRP3080, RHRP3090, RHRP3100

Electrical Specifications $T_C = +25^\circ\text{C}$, Unless Otherwise Specified

SYMBOL	TEST CONDITION	RHRP3070			RHRP3080			RHRP3090			RHRP3100			UNITS
		MIN	TYP	MAX	MIN	TYP	MAX	MIN	TYP	MAX	MIN	TYP	MAX	
V_F	$I_F = 30\text{A}, T_C = +25^\circ\text{C}$	-	-	3.0	-	-	3.0	-	-	3.0	-	-	3.0	V
	$I_F = 30\text{A}, T_C = +150^\circ\text{C}$	-	-	2.5	-	-	2.5	-	-	2.5	-	-	2.5	V
I_R	$V_R = 700\text{V}, T_C = +25^\circ\text{C}$	-	-	500	-	-	-	-	-	-	-	-	-	μA
	$V_R = 800\text{V}, T_C = +25^\circ\text{C}$	-	-	-	-	-	500	-	-	-	-	-	-	μA
	$V_R = 900\text{V}, T_C = +25^\circ\text{C}$	-	-	-	-	-	-	-	-	500	-	-	-	μA
	$V_R = 1000\text{V}, T_C = +25^\circ\text{C}$	-	-	-	-	-	-	-	-	-	-	-	500	μA
I_R	$V_R = 700\text{V}, T_C = +150^\circ\text{C}$	-	-	1.0	-	-	-	-	-	-	-	-	-	mA
	$V_R = 800\text{V}, T_C = +150^\circ\text{C}$	-	-	-	-	-	1.0	-	-	-	-	-	-	mA
	$V_R = 900\text{V}, T_C = +150^\circ\text{C}$	-	-	-	-	-	-	-	-	1.0	-	-	-	mA
	$V_R = 1000\text{V}, T_C = +150^\circ\text{C}$	-	-	-	-	-	-	-	-	-	-	-	1.0	mA
t_{RR}	$I_F = 1\text{A}, di_F/dt = 100\text{A}/\mu\text{s}$	-	-	65	-	-	65	-	-	65	-	-	65	ns
	$I_F = 30\text{A}, di_F/dt = 100\text{A}/\mu\text{s}$	-	-	75	-	-	75	-	-	75	-	-	75	ns
t_A	$I_F = 30\text{A}, di_F/dt = 100\text{A}/\mu\text{s}$	-	35	-	-	35	-	-	35	-	-	35	-	ns
t_B	$I_F = 30\text{A}, di_F/dt = 100\text{A}/\mu\text{s}$	-	33	-	-	33	-	-	33	-	-	33	-	ns
Q_{RR}	$I_F = 30\text{A}, di_F/dt = 100\text{A}/\mu\text{s}$	-	200	-	-	200	-	-	200	-	-	200	-	nC
C_J	$V_R = 10\text{V}, I_F = 0\text{A}$	-	100	-	-	100	-	-	100	-	-	100	-	pF
$R_{\theta JC}$		-	-	1.2	-	-	1.2	-	-	1.2	-	-	1.2	$^\circ\text{C}/\text{W}$

DEFINITIONS

V_F = Instantaneous forward voltage (pw = 300 μs , D = 2%).

I_R = Instantaneous reverse current.

t_{RR} = Reverse recovery time (Figure 2), summation of $t_A + t_B$.

t_A = Time to reach peak reverse current (See Figure 2).

t_B = Time from peak I_{RM} to projected zero crossing of I_{RM} based on a straight line from peak I_{RM} through 25% of I_{RM} (See Figure 2).

Q_{RR} = Reverse recovery charge.

C_J = Junction Capacitance.

$R_{\theta JC}$ = Thermal resistance junction to case.

E_{AVL} = Controlled avalanche energy. (See Figures 10 and 11).

pw = pulse width.

D = duty cycle.

7
**HYPERFAST
SINGLE DIODES**

V_1 AMPLITUDE CONTROLS I_F
 V_2 AMPLITUDE CONTROLS di_F/dt
 L_1 = SELF INDUCTANCE OF
 $R_4 + L_{\text{LOOP}}$

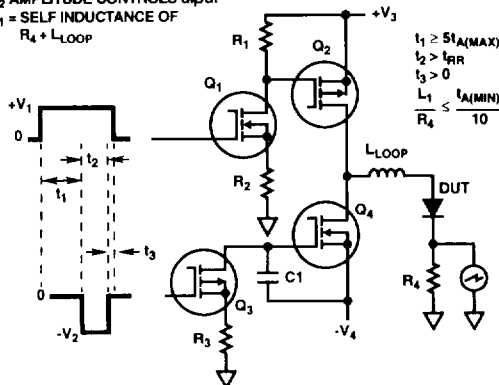

FIGURE 1. t_{RR} TEST CIRCUIT

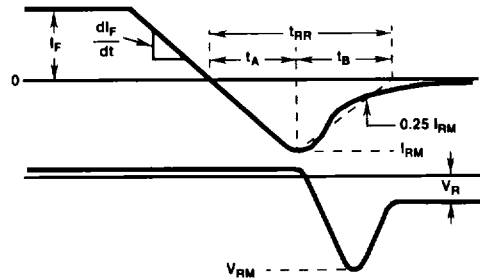

FIGURE 2. t_{RR} WAVEFORMS AND DEFINITIONS

Typical Performance Curves

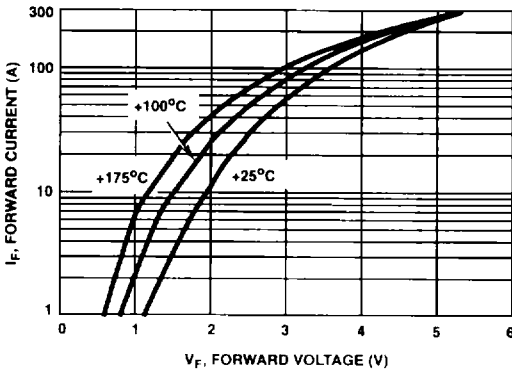

FIGURE 3. TYPICAL FORWARD CURRENT vs FORWARD VOLTAGE DROP

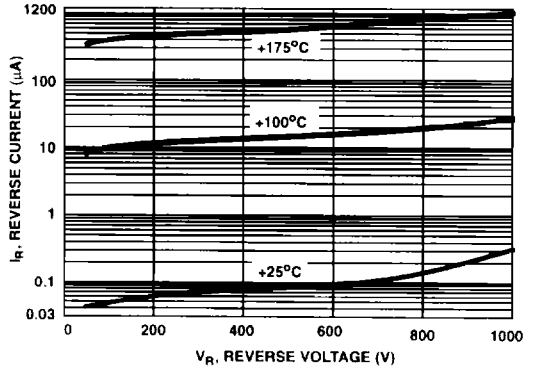

FIGURE 4. TYPICAL REVERSE CURRENT vs REVERSE VOLTAGE

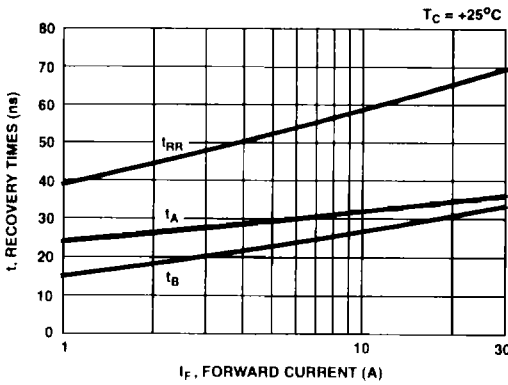

FIGURE 5. TYPICAL t_{RR} , t_A AND t_B CURVES vs FORWARD CURRENT AT +25°C

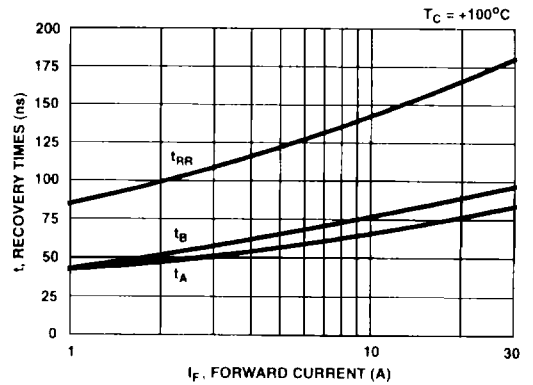

FIGURE 6. TYPICAL t_{RR} , t_A AND t_B CURVES vs FORWARD CURRENT AT +100°C

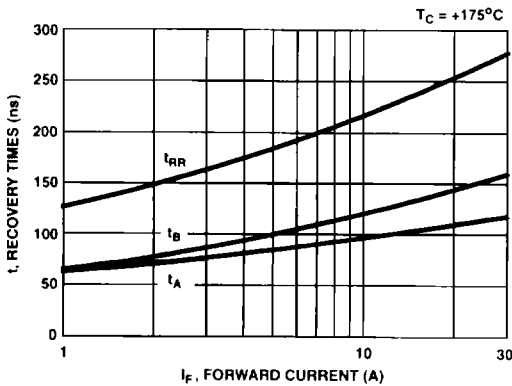

FIGURE 7. TYPICAL t_{RR} , t_A AND t_B CURVES vs FORWARD CURRENT AT +175°C

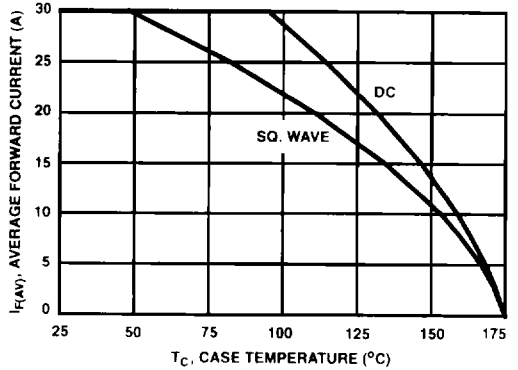

FIGURE 8. CURRENT DERATING CURVE FOR ALL TYPES

Typical Performance Curves (Continued)

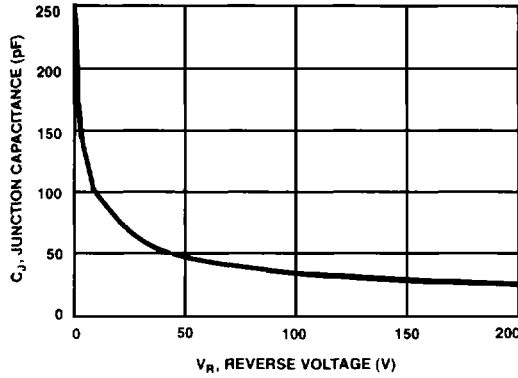

FIGURE 9. TYPICAL JUNCTION CAPACITANCE vs REVERSE VOLTAGE

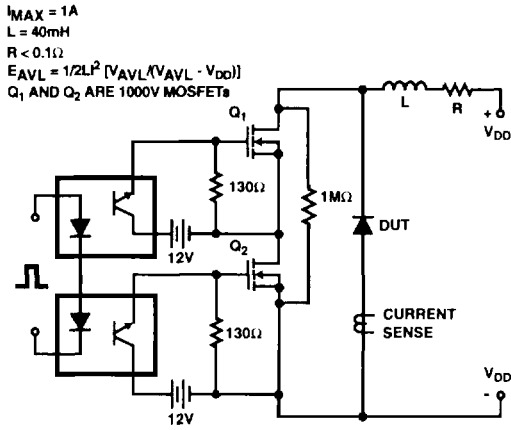

FIGURE 10. AVALANCHE ENERGY TEST CIRCUIT

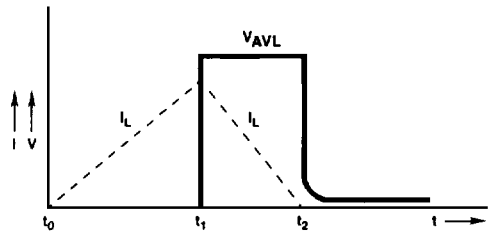

FIGURE 11. AVALANCHE CURRENT AND VOLTAGE WAVEFORMS