

THIS DRAWING IS UNPUBLISHED. RELEASED FOR PUBLICATION
 © COPYRIGHT 2011 BY TYCO ELECTRONICS CORPORATION. ALL RIGHTS RESERVED.

LOC		DIST		REVISIONS			
P	LTR	DESCRIPTION		DATE	DWN	APVD	
B3		REVISED (ECR-18-013655)		19NOV18	E.Z	W.H	

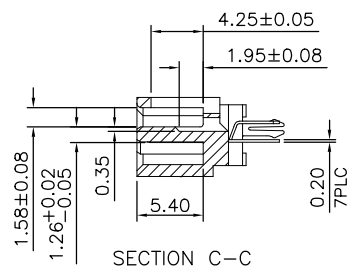

NOTE:
 1. MATERIAL:
 1.1 HOUSING: PA9T WITH 30% GF, UL 94V-0, COLOR: SEE TABLE
 1.2 CONTACT: BRASS
 1.3 BOARDLOCK: BRASS
 2. FINISH:
 2.1 CONTACT: 0.381um[15u"] GOLD PLATED ON CONTACT AREA.
 2.54um[100u"] MIN. MATTE-TIN ON SOLDER TAIL
 1.27um[50u"] MIN. NICKEL UNDERPLATED OVERALL
 2.2 BOARDLOCK: 2.54um[100u"] MIN. MATTE-TIN PLATED OVERALL
 1.27um[50u"] MIN. NICKEL UNDERPLATED OVERALL
 3. WAVE SOLDER CAPABLE TO 265°C PER TE SPEC. 109-202, CONDITION B.

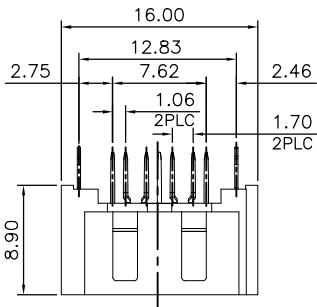
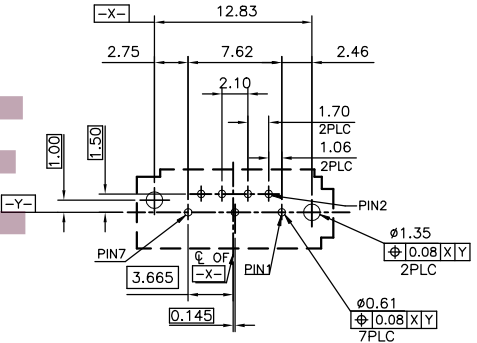
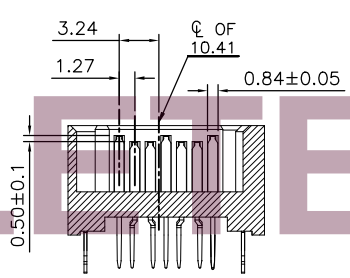
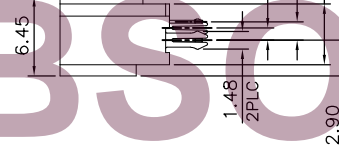
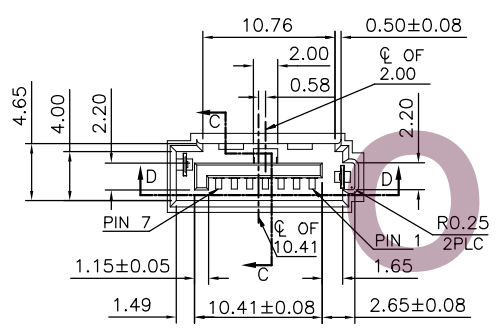

RECOMMENDED PCB LAYOUT
 THICKNESS: 1.6mm; TOLERANCE:±0.05

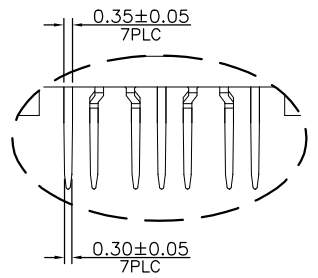
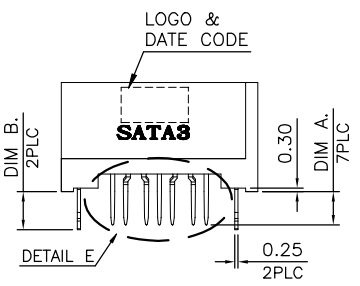

DETAIL E
 SCALE 2:1

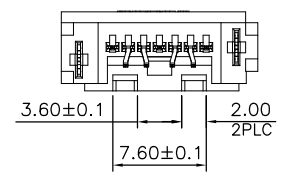
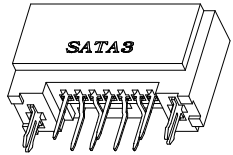

OBSOLETE	DIM B.	DIM A.	HOUSING COLOR	PART NUMBER
	2.50	2.10	BLUE(287C)	2041346-1
			RED(186C)	-2041346-4
			RED(184C)	-2041346-3
	3.10	2.70	BLACK	-2041346-2
			BLUE(287C)	-2041346-1

THIS DRAWING IS A CONTROLLED DOCUMENT.		DWN J. LAI 28JUN2011	TE Connectivity	
DIMENSIONS: mm		CHK S. CHIEN 28JUN2011		
TOLERANCES UNLESS OTHERWISE SPECIFIED:		APVD W. KODAMA 28JUN2011	NAME SIGNAL SATA3, 7P, DIP TYPE	
0 PLC ± - 1 PLC ± 0.3 2 PLC ± 0.2 3 PLC ± 0.15 4 PLC ± - ANGLES ± 3°		PRODUCT SPEC 108-57857	SIZE A3	CAGE CODE 00779
MATERIAL SEE NOTE		FINISH SEE NOTE	DRAWING NO C=2041346	RESTRICTED TO
CUSTOMER DRAWING		WEIGHT 0.782 GRAMS	SCALE -	SHEET 1 OF 2
				REV B3

LOC	DIST	REVISIONS			
P	LTR	DESCRIPTION	DATE	DWN	APVD
		SEE SHEET 1.			

D
C
B
A

D
C
B
A

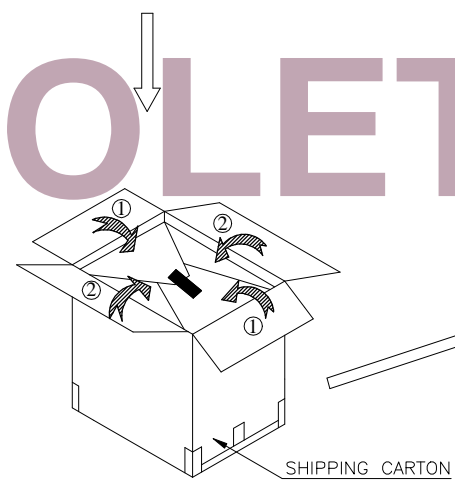
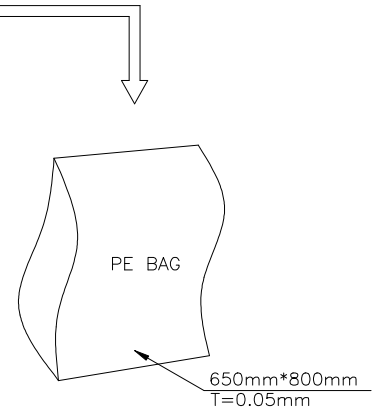
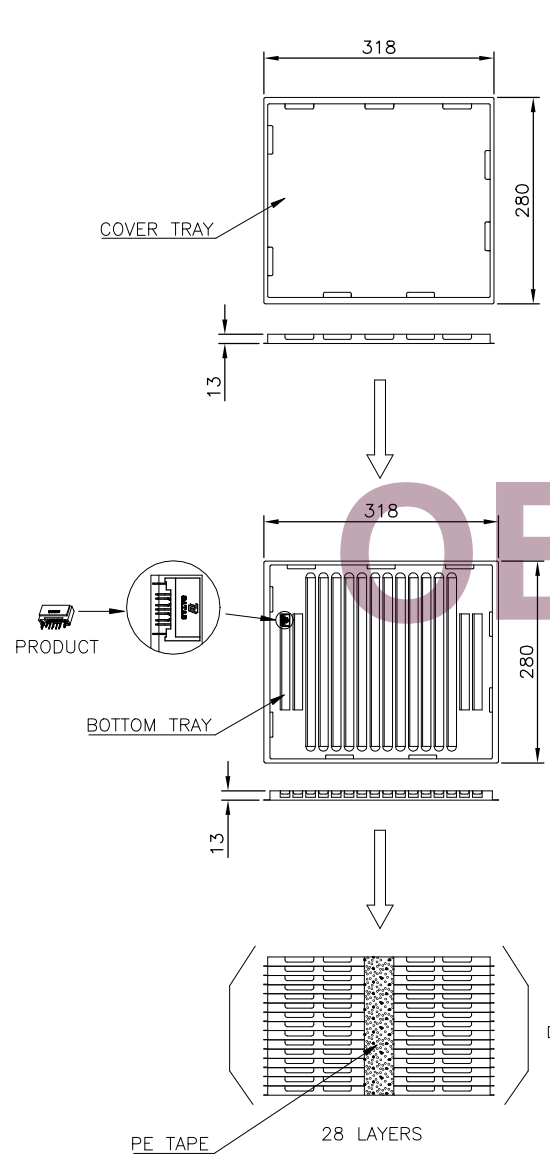

- NOTES:
 PACKING MATERIAL MET TEC 138-702.
- MATERIAL:
 COVER TRAY: PVC.
 BOTTOM TRAY: PVC.
 BAG: PE.
 SHIPPING CARTON: CORRUGATED FIBER.
 - DIMENSION:
 COVER TRAY: SEE DWG.
 BOTTOM TRAY: SEE DWG.
 BAG: SEE DWG.
 SHIPPING CARTON: SEE DWG.

OBSOLETE

5.45KG	4.38KG	200	28	5600	±=2041346-1 -2041346-4 -2041346-3 -2041346-2 -2041346-1
GROSS WEIGHT	NET WEIGHT	PCS/TRAY	TRAY/BOX	PCS/BOX	PART NUMBER

THIS DRAWING IS A CONTROLLED DOCUMENT.		DWN	TE TE Connectivity		
DIMENSIONS: mm		CHK			
TOLERANCES UNLESS OTHERWISE SPECIFIED:		APVD	NAME		
0 PLC ± -		PRODUCT SPEC	SIGNAL SATA3, 7P, DIP TYPE		
1 PLC ± 0.3		APPLICATION SPEC	SIZE	CAGE CODE	DRAWING NO
2 PLC ± 0.2		WEIGHT	A3	00779	C=2041346
3 PLC ± 0.15		CUSTOMER DRAWING	RESTRICTED TO		
4 PLC ANGLES ± 3°		SCALE	SHEET 2 OF 2		
MATERIAL FINISH			REV B3		