

MAXIM

MAX4313 Evaluation Kit

General Description

The MAX4313 evaluation kit (EV kit) simplifies evaluation of the MAX4313 low-power, single-supply video multiplexer/amplifier. The MAX4313 is fixed to a gain of +2V/V, ideal for driving back-terminated cables. SMA connectors and 50Ω terminating resistors are included for 50Ω test equipment compatibility. Simply change the terminating resistors to 75Ω for video test equipment compatibility.

The EV kit comes with the MAX4313 installed. To evaluate the MAX4310, simply order a free sample (MAX4310ESA), replace the MAX4313 with the MAX4310 on the EV board, and change the gain-setting resistors for the desired gain.

Component List

DESIGNATION	QTY	DESCRIPTION
C1, C3	2	0.1μF, 10% ceramic capacitors
C2, C4	2	10μF, 10V, 20% tantalum capacitors AVX TAJB106M010 or Sprague 293D106X0010B
R1–R3	3	49.9Ω, 1% resistors
R _G	1	0Ω resistor
R _F	0	Not installed
IN0, IN1, OUT	3	SMA connectors
JU1, JU2	2	3-pin headers
U1	1	MAX4313ESA
None	2	Shunts for JU1, JU2
None	1	MAX4313 EV kit PC board

Component Suppliers

SUPPLIER	PHONE	FAX
AVX	803-946-0690	803-626-3123
Sprague	603-224-1961	603-224-1430

Note: Please indicate that you are using the MAX4313 when contacting these component suppliers.

Features

- ◆ Single-Supply Operation
- ◆ 150MHz -3dB Bandwidth ($R_L = 150\Omega$)
- ◆ 540V/μs Slew Rate ($R_L = 150\Omega$)
- ◆ 40MHz 0.1dB Gain Flatness ($R_L = 150\Omega$)
- ◆ Low Switching Transient (20mVp-p)
- ◆ 0.06%/0.02° Gain/Phase Errors
- ◆ Outputs Extend to the Rails
- ◆ Fully Assembled and Tested Surface-Mount Board

Ordering Information

PART	TEMP. RANGE	IC PACKAGE
MAX4313EVKIT	-40°C to +85°C	8 SO

Note: To evaluate the MAX4310, request a MAX4310ESA free sample.

Quick Start

The MAX4313 EV kit is fully assembled and tested. Follow these steps to verify board operation.

- 1) The circuit requires supply voltages of +4.5V to +10.5V. For evaluation purposes, connect a +5V supply to the pad labeled VCC and connect the power-supply ground to the pads labeled VEE and GND.
- 2) Connect the output labeled OUT to an oscilloscope input. Set the shunt across the appropriate pins of jumper JU1 to select a multiplexer input (IN0 or IN1).
- 3) Place the shunt across pins 2 and 3 of jumper JU2 to enable the MAX4313's output.
- 4) Turn on the power supply. Apply a ±0.5V signal with $V_{CM} = +1.5V$ to the appropriate multiplexer input selected in Step 2. The 100Ω load (chosen for ease of evaluation) limits the output voltage range. Wider output voltage swings are achievable with lighter loads. See the MAX4310/MAX4313 data sheet.
- 5) Verify the output signal on the oscilloscope.

Evaluates: MAX4310/MAX4313

MAX4313 Evaluation Kit

Detailed Description

Setting the Voltage Gain (MAX4310)

The gain of the MAX4310's amplifier can be set by changing the feedback (R_F) and gain-set (R_G) resistors. Refer to the MAX4310/MAX4313 data sheet for recommended values.

Control of Digital Inputs (A0, $\overline{\text{SHDN}}$)

Jumpers JU1 and JU2 provide the user with manual control of the multiplexer input address (A0) and shutdown ($\overline{\text{SHDN}}$), respectively (Table 1). An external controller may also be used on either input by connecting the controller to the appropriate pad and removing the shunt from JU1 or JU2. The MAX4313's A0 and $\overline{\text{SHDN}}$ pins should **not** be left floating. For a single +5V supply, A0 and $\overline{\text{SHDN}}$ are CMOS-logic compatible. The logic-high threshold is $V_{CC} - 1.2V$, and the logic-low threshold is $V_{CC} - 2.8V$.

Layout Considerations

The PC board layout has been optimized for high-speed signals and low distortion, with careful attention given to grounding, power-supply bypassing, and signal-

Table 1. Jumper Selection

JUMPER	JUMPER POSITION	FUNCTION
JU1	1–2	Select IN1.
	2–3	Select IN0.
	Open	Drive pad A0 with external signal.
JU2	1–2	Disable output.
	2–3	Enable output.
	Open	Drive pad $\overline{\text{SHDN}}$ with external signal.

path layout. The small, surface-mount, ceramic bypass capacitors (C1, C3) have been placed as close as possible to the amplifier's supply pins. The ground plane has been removed around and under the amplifier to reduce stray capacitance. Capacitance at the feedback pin has been minimized by using 0805-size feedback and gain-set resistors and by removing the adjacent ground plane.

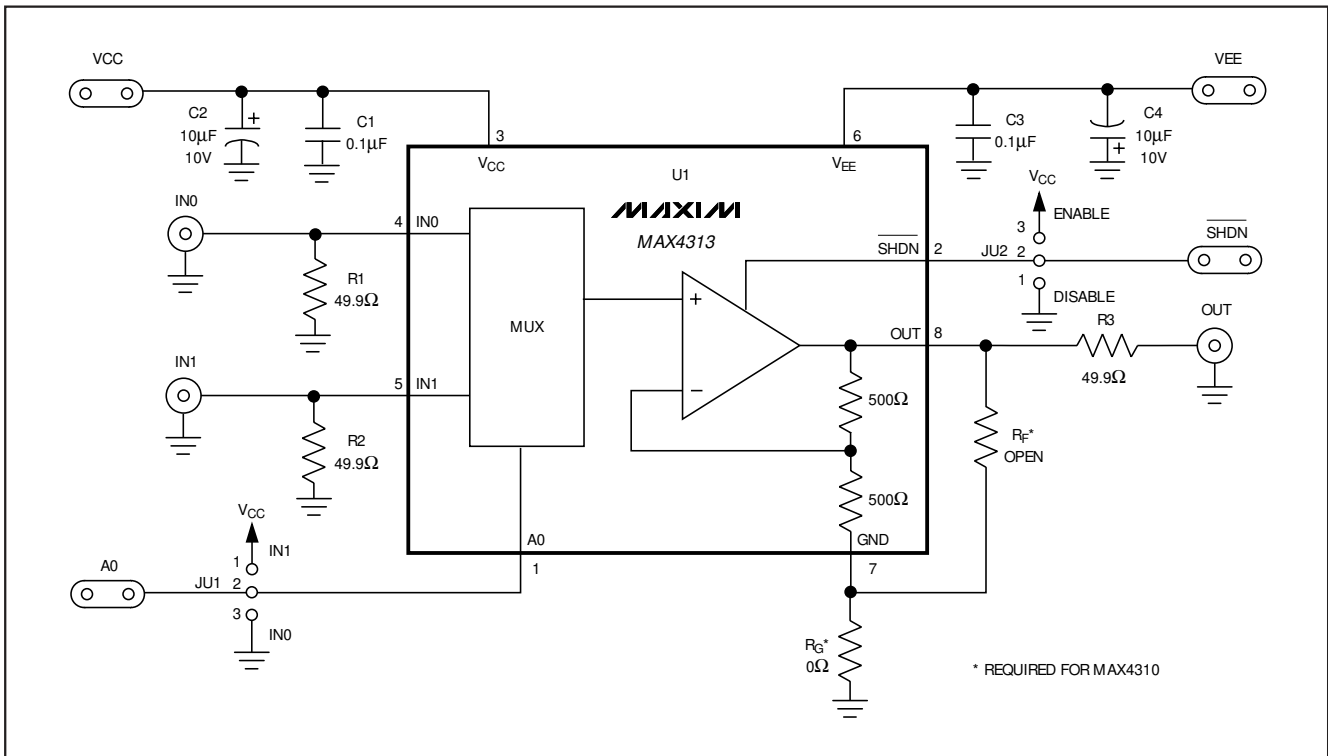

Figure 1. MAX4313 EV Kit Schematic

MAX4313 Evaluation Kit

Evaluates: MAX4310/MAX4313

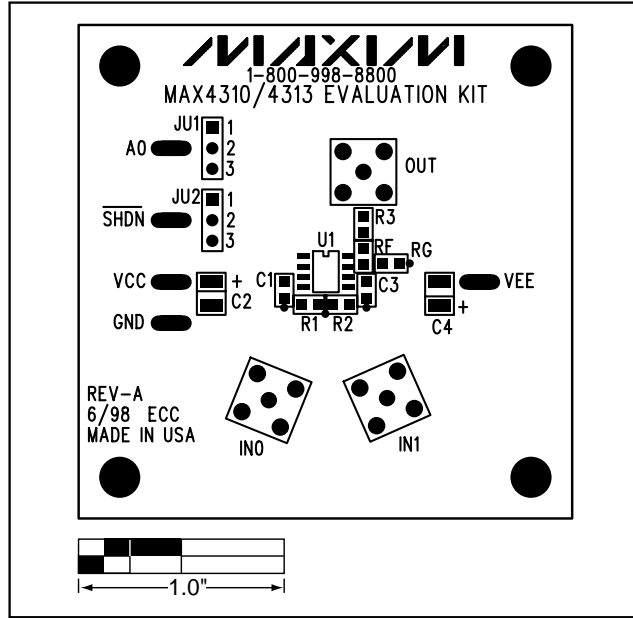

Figure 2. MAX4313 EV Kit Component Placement Guide—Component Side

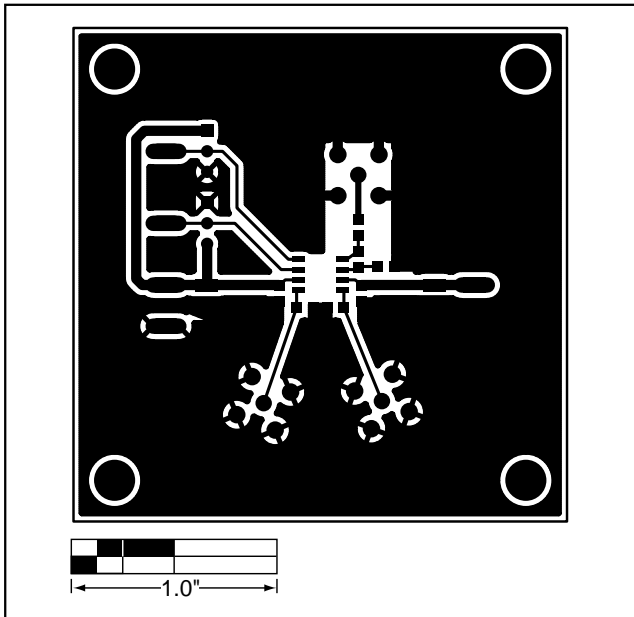

Figure 3. MAX4313 EV Kit PC Board Layout Guide—Component Side

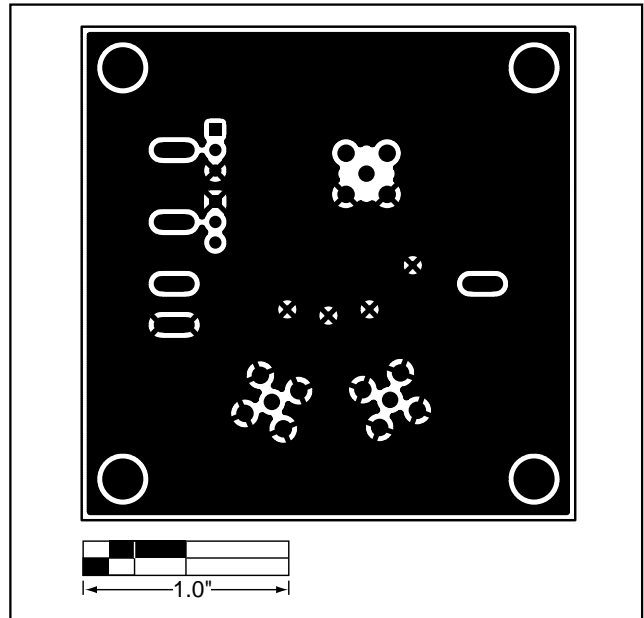

Figure 4. MAX4313 EV Kit PC Board Layout Guide—Solder Side

MAX4313 Evaluation Kit

Evaluates: MAX4310/MAX4313

NOTES

Maxim cannot assume responsibility for use of any circuitry other than circuitry entirely embodied in a Maxim product. No circuit patent licenses are implied. Maxim reserves the right to change the circuitry and specifications without notice at any time.

4 _____ **Maxim Integrated Products, 120 San Gabriel Drive, Sunnyvale, CA 94086 408-737-7600**

© 1999 Maxim Integrated Products

Printed USA

MAXIM is a registered trademark of Maxim Integrated Products.