

RECOMMENDED PLATED THRU HOLE PATTERN

MATERIAL NUMBER (STD.)	MATERIAL NUMBER (-56)	MATERIAL NUMBER (-50)	NO. OF CIRCUITS	A	B
386306602	386390109	386307802	2	25.9 (1.02)	11.13 (.438)
386306603	386390110	386307803	3	37.1 (1.46)	22.22 (.875)
386306604	386390111	386307804	4	48.3 (1.90)	33.35 (1.313)
386306605	386390112	386307805	5	59.2 (2.33)	44.45 (1.750)
386306606	386390113	386307806	6	70.4 (2.77)	55.57 (2.188)
386306607	386390114	386307807	7	81.5 (3.21)	66.67 (2.625)
386306608	386390115	386307808	8	92.7 (3.65)	77.80 (3.063)
386306609	386390116	386307809	9	103.6 (4.08)	88.90 (3.500)
386306610	386390117	386307810	10	114.8 (4.52)	100.03 (3.938)
386306611	386390118	386307811	11	125.9 (4.96)	111.13 (4.375)
386306612	386390119	386307812	12	137.2 (5.40)	122.25 (4.813)
386306613	386390120	386307813	13	148.1 (5.83)	133.35 (5.250)
386306614	386390121	386307814	14	159.3 (6.27)	144.45 (5.687)
386306615	386390122	386307815	15	170.4 (6.71)	155.58 (6.125)
386306616	386390123	386307816	16	181.6 (7.15)	166.70 (6.563)

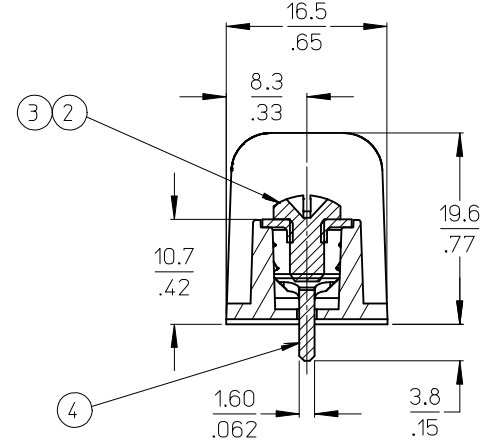

SECTION Z-Z

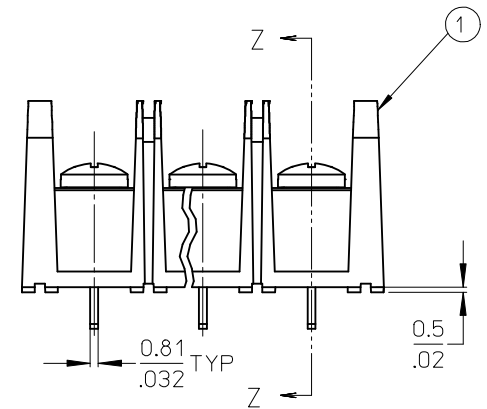
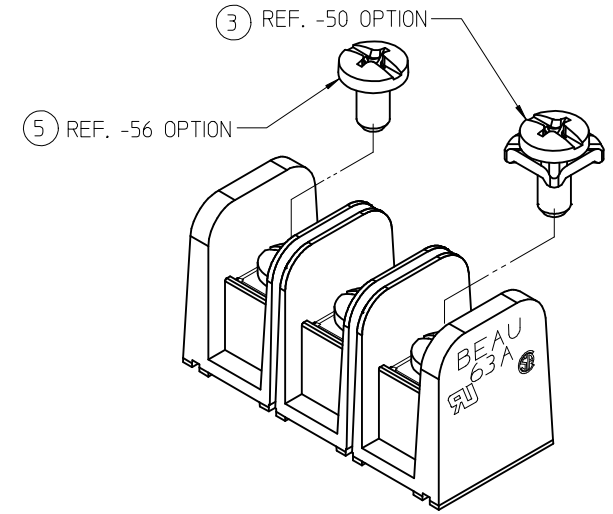

- NOTES:
1. MATERIAL: SEE TABLE
 2. FINISHES: SEE TABLE
 3. *XX* REFERS TO QTY. OF CIRCUITS.
 4. ASSEMBLY IS ROHS COMPLIANT.

ITEM	QTY.	DESCRIPTION	MATERIAL	FINISH
5	XX	SCREW #6-32X.250 BHD, PH-SL STAINLESS (-56 OPT)	STAINLESS STL	PASSIVATE
4	XX	TERMINAL, PC (SHORT)	BRASS	TIN PLATE
3	XX	SCREW/WSHR #6-32X.250 PAN, PH-SL (-50)	STEEL	ZN, CLEAR CHROMATE
2	XX	SCREW #6-32X.250 BHD, PH-SL (STD)	STEEL	ZN, CLEAR CHROMATE
1	1	BARRIER TERMINAL STRIP	POLYESTER (PBT)	BLACK

CHG SS SCREW DRIVE RECESS
 EC NO: IPG2013-0364
 DRAWN: CLYORK 2010/08/16
 CHKD: JMACNEIL 2012/09/12
 APPR: JMACNEIL 2012/11/05
 REV DESCRIPTION

QUALITY SYMBOLS
 ▽=0
 ▽=0

GENERAL TOLERANCES (UNLESS SPECIFIED)

	mm	INCH
4 PLACES	± .005	± .0005
3 PLACES	± .01	± .001
2 PLACES	± 0.13	± .01
1 PLACE	± 0.3	± .0125

ANGULAR ± 2°

DRAFT WHERE APPLICABLE MUST REMAIN WITHIN DIMENSIONS

DIMENSION STYLE
MM/IN

SCALE
2:1

DESIGN UNITS
INCH

THIRD ANGLE PROJECTION

DRAWN BY: R. STONE
 DATE: 2003/03/25

CHECKED BY: R. KEMP
 DATE: 2003/03/27

APPROVED BY: P. WALTZ
 DATE: 2003/03/28

TITLE
**11.13/.438" PCB BTS 600V
 NO MTG ENDS, STD LENGTH
 (63A5XX-C)**

MOLEX INCORPORATED

MATERIAL NO. SEE CHART
 DOCUMENT NO. SD-38630-008

SHEET NO. 1 OF 1

THIS DRAWING CONTAINS INFORMATION THAT IS PROPRIETARY TO MOLEX INCORPORATED AND SHOULD NOT BE USED WITHOUT WRITTEN PERMISSION