



### Electrical Specifications

**Cutoff Frequency (Fc):** 8 MHz  
**Passband:** 8-240 MHz  
**Insertion Loss @ 16MHz:** 0.5dB Max.  
**Passband Return Loss:** 15dB Min.  
**Rejection:** 51 dB Min. @ 3.02 MHz

### Mechanical

**Connector Type:** BNC(M) & BNC(F)  
**Dimensions:** 2.5" x 1.125" x 0.75"

### Environmental

**Operating Temperature:** -25°C to +70°C  
**Storage Temperature:** -60°C to +90°C  
**Shock:** 10 G. 11ms  
**Vibration:** 10 G. 5 to 200Hz

### Outline Drawing:

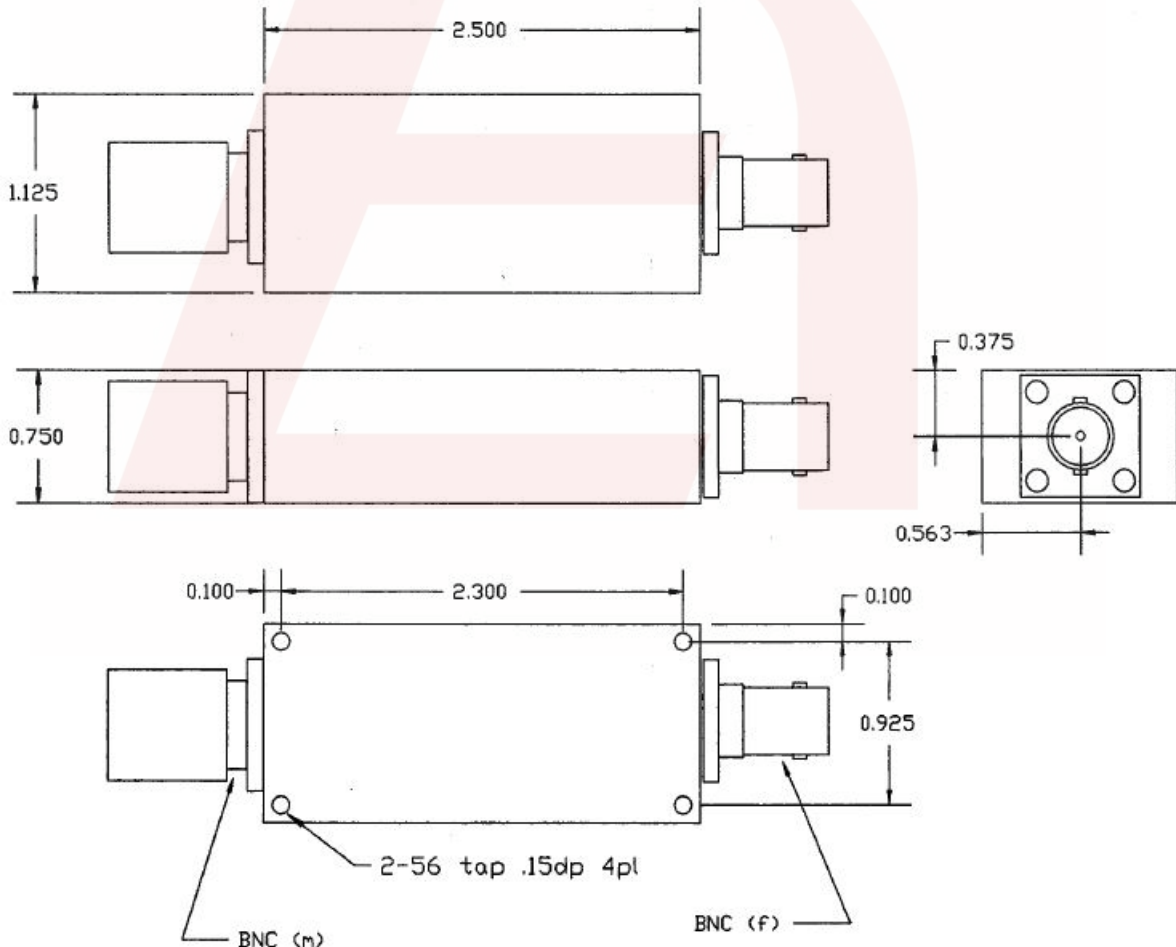



**Response Plot :**

