

PART NUMBER
SEE SHEET 2

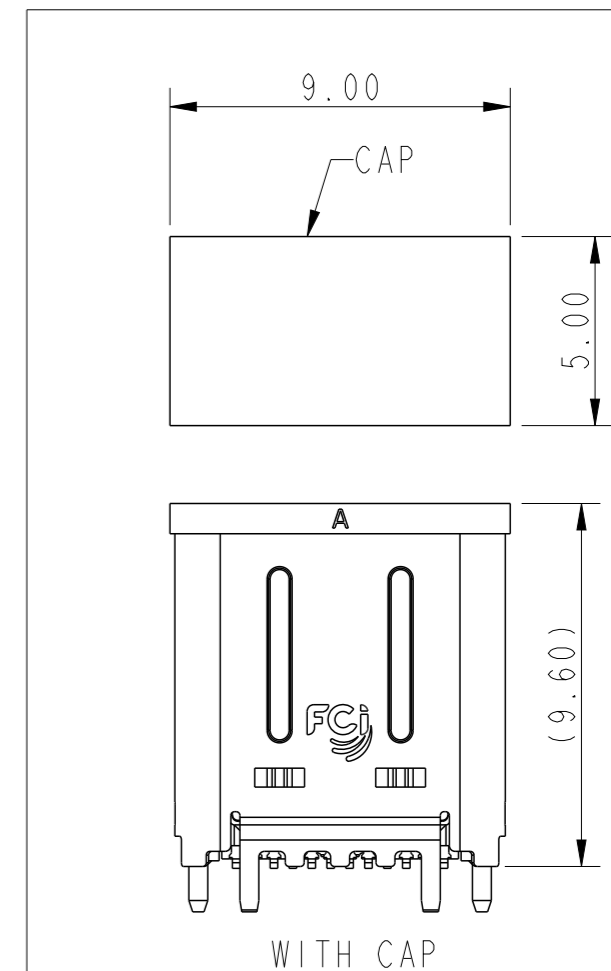
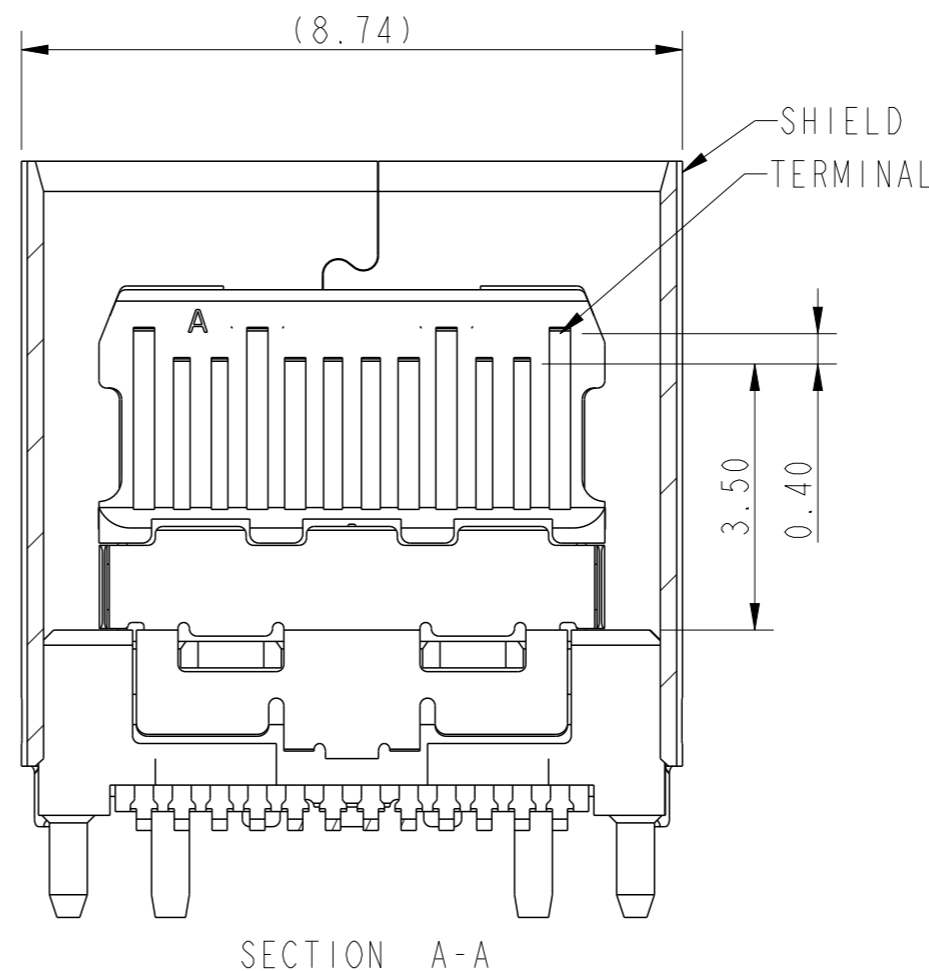
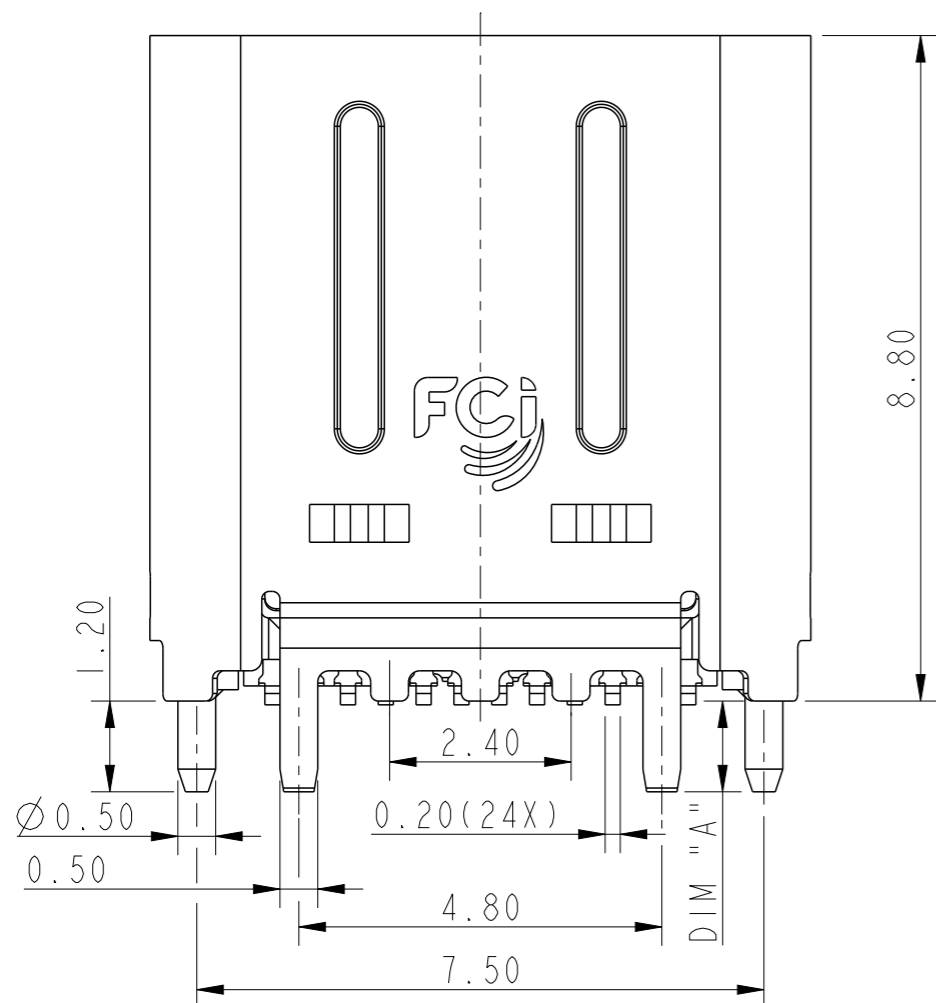
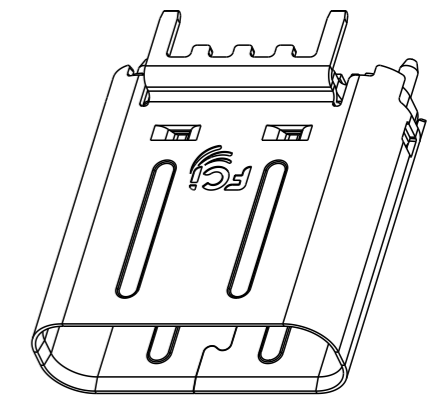
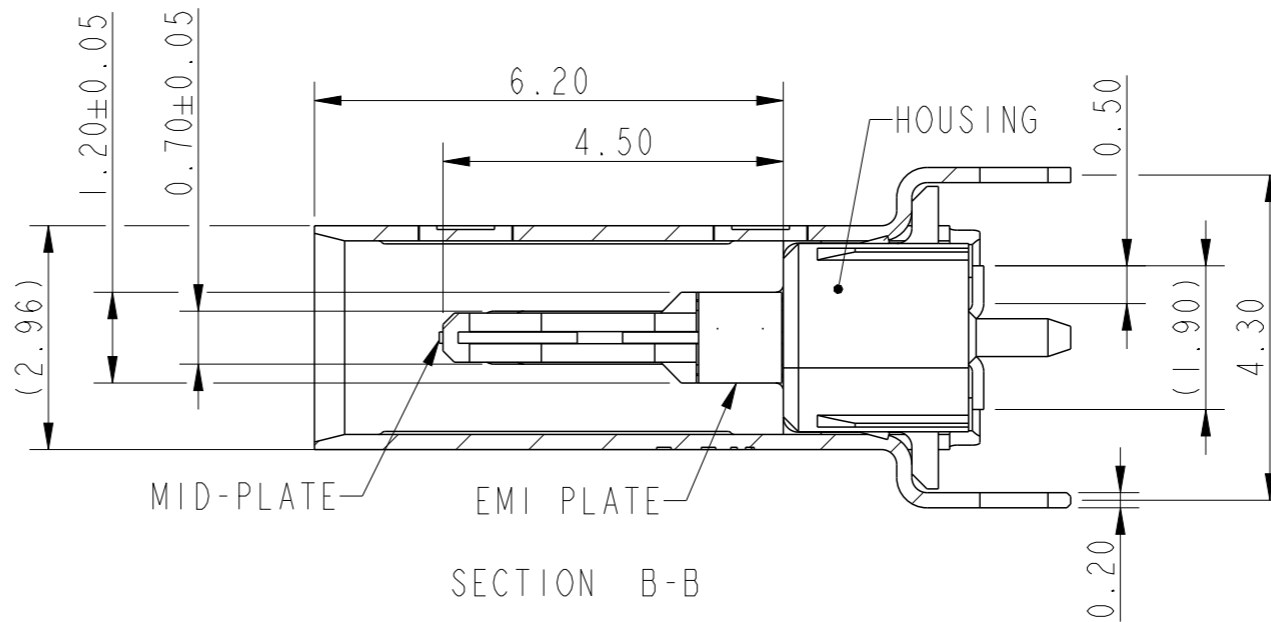
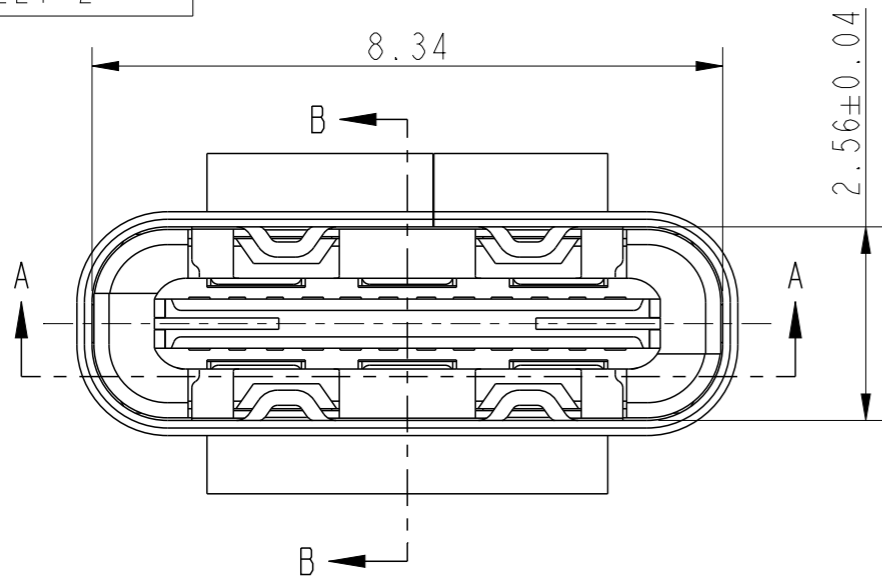

spec ref	-	dr	Li-Qing Lei	2014/11/20	projection	mm	size	A3	scale	10:1	
tolerance std	ISO 406 ISO 1101	eng	Li-Qing Lei	2020/07/24			ecn no	ELX-N-37761-1			
TOLERANCES UNLESS OTHERWISE SPECIFIED		chr	-	-			rel level	Released			
surface	linear	0.X	±0.25	Amphenol FCI	product family	-	dwg no	10132328		rev	B
		0.XX	±0.15		USB3.1 Type-C	cat. no.	-	Product - Customer Drw	sheet 1 of 3		
	angular	0°	±2°		Vertical, Receptacle						

NOTE:

1. MATERIAL:
 - 1.1 HSG: THERMOPLASTIC, BLACK, UL94-V0
 - 1.2 TERMINAL: COPPER ALLOY
 - 1.3 EMI PLATE: STAINLESS STEEL
 - 1.4 MID PLATE: STAINLESS STEEL
 - 1.5 SHIELD: STAINLESS STEEL
2. PLATING:
 - 2.1 TERMINAL: (Min) 0.05 um Au + (Min) 0.75 um Ni-Pd ON CONTACT AREA
 - 2.2 SHELL: PLATING 0.74um MIN Ni OVER AREA.
 - 2.3 EMI: PLATING 0.74um MIN Ni OVER AREA.
 - 2.4 CENTER PLATE: PLATING 0.74 MIN Ni OVER AREA.
3. MECHANICAL CHARACTER:
 - 3.1 INSERTION FORCE: 5~20N;
 - 3.2 EXTRACTION FORCE: 8~20N INITIAL, 6~20N AFTER DURABILITY;
 - 3.3 DURABILITY: 10,000 CYCLES;
 - 3.4 OPERATION TEMPERATURE: -55°C TO +85°C
4. ELECTRICAL CHARACTER:
 - 4.1 LLCR : 40mΩ INITIAL, 50mΩ MAX AFTER ENVIRONMENT TEST;
 - 4.2 INSULATION RESISTANCE: 100MΩ MIN AT 250V DC.
 - 4.3 DIELECTRIC WITHSTAND VOLTAGE: 100VAC MIN.
5. THE HOUSING WILL WITHSTAND EXPOSURE TO 260°C PEAK TEMPERATURE FOR 20 SECONDS IN A CONVECTION, INFRA-RED OR VAPOR PHASE REFLOW ;
6. LEAD FREE PRODUCT MEETS EUROPEAN UNION DIRECTIVES AND OTHER COUNTRY REGULATIONS AS DISCRIBLED IN GS-22-008
7. PRODUCT SPEC: GS-12-1351 FOR GENERAL CUSTOMER
GS-12-1299 FOR DEDICATED CUSTOMER
8. SOLDER TAILL TO BE COPLANAR WITHIN 0.10 TO EACH OTHER
PRODUCT NUMBER CODE:
10132328-100XXLF

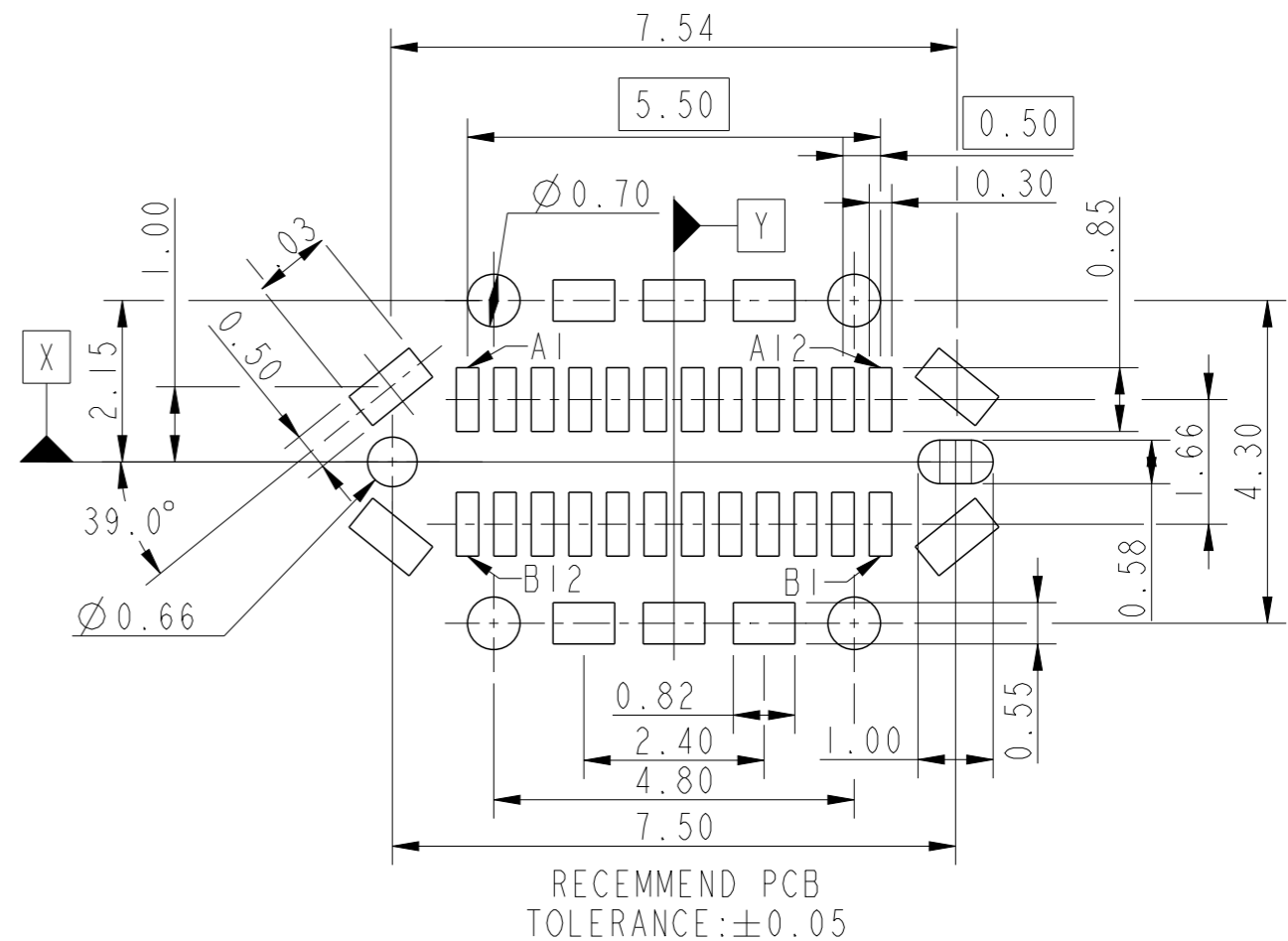

6 SMT TAILS

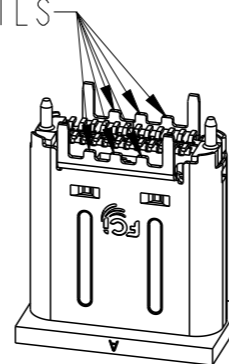

- THE LENGTH OF SHELL'S LEG OPTION
1. DIM"A"=1.2 WITH 6 SMT TAILS IN THE MIDDLE
 2. DIM"A"=1.6 WITH 6 SMT TAILS IN THE MIDDLE
 3. DIM"A"=1.2 WITHOUT 6 SMT TAILS IN THE MIDDLE
 4. DIM"A"=1.6 WITHOUT 6 SMT TAILS IN THE MIDDLE

- GROUND PIN STATUS (A1/A12/B1/B12)
0. SEPARATED
 1. CONNECTED

PIN ASSIGNMENTS

PIN	SIGNAL NAME	PIN	SIGNAL NAME
A1	GND	B12	GND
A2	SSTXp1	B11	SSRXp1
A3	SSTXn1	B10	SSRXn1
A4	VBUS	B9	VBUS
A5	CC1	B8	SBU2
A6	Dp1	B7	Dn2
A7	Dn1	B6	Dp2
A8	SBU1	B5	CC2
A9	VBUS	B4	VBUS
A10	SSRXn2	B3	SSTXn2
A11	SSRXp2	B2	SSTXp2
A12	GND	B1	GND

NOTE: TX AND RX ARE DEFINED FORM THE HOST PERSPECTIVE

AVAILABLE P/N:
10132328-10001LF
10132328-10011LF
10132328-10013LF

spec ref	-	dr	Li-Qing Lei	2014/11/20	projection	mm	size	A3	scale	10:1	
tolerance std	ISO 406 ISO 1101	eng	Li-Qing Lei	2020/07/24			ecn no	ELX-N-37761-1			
TOLERANCES UNLESS OTHERWISE SPECIFIED		chr	-	-			rel level	Released			
surface	linear	appr	Tim Yao	2020/07/29	product family		dwg no	10132328		rev	B
	angular										
					cat. no.		Product - Customer Drw	sheet 2 of 3			

TAPE REEL PACKAGE
Q'TY: (350)EA/REEL

A

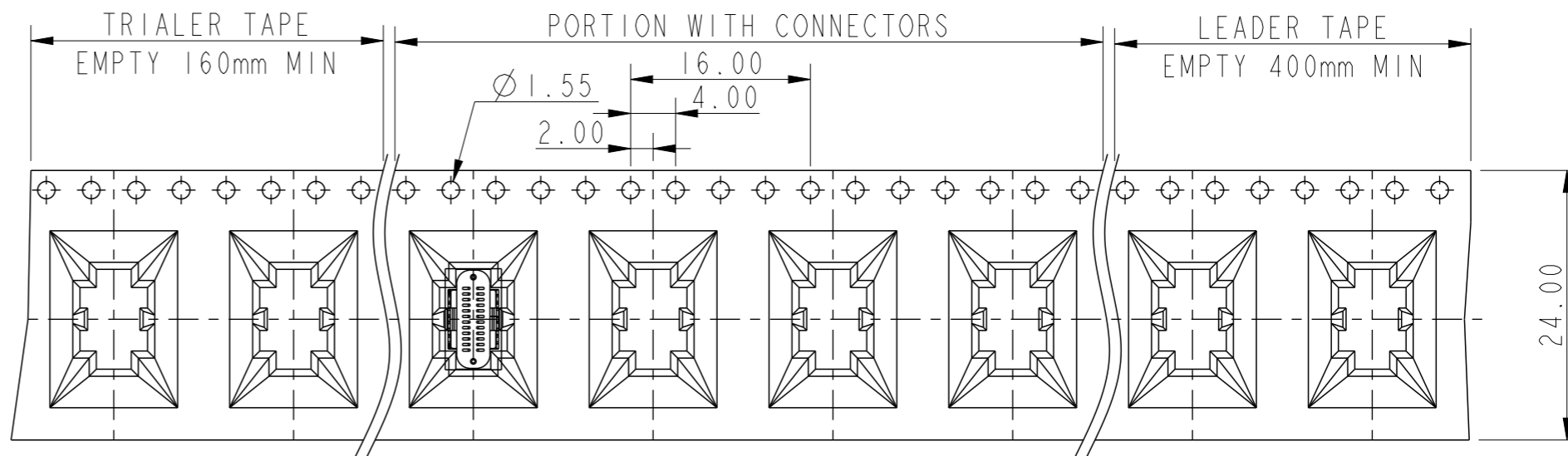
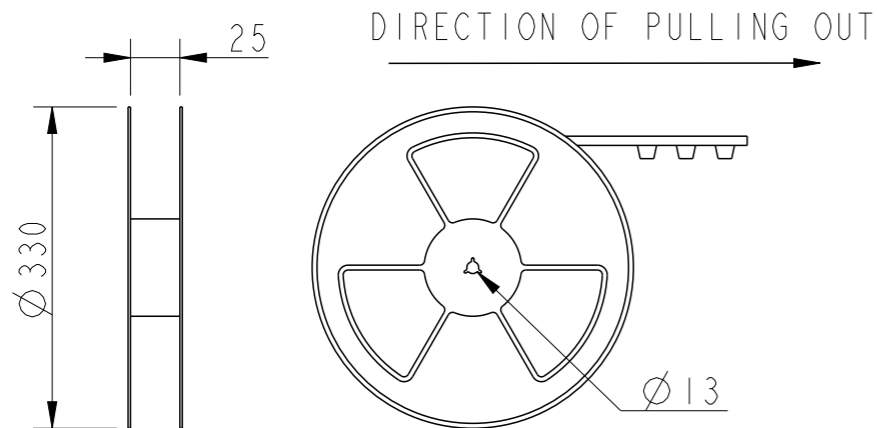

B

B

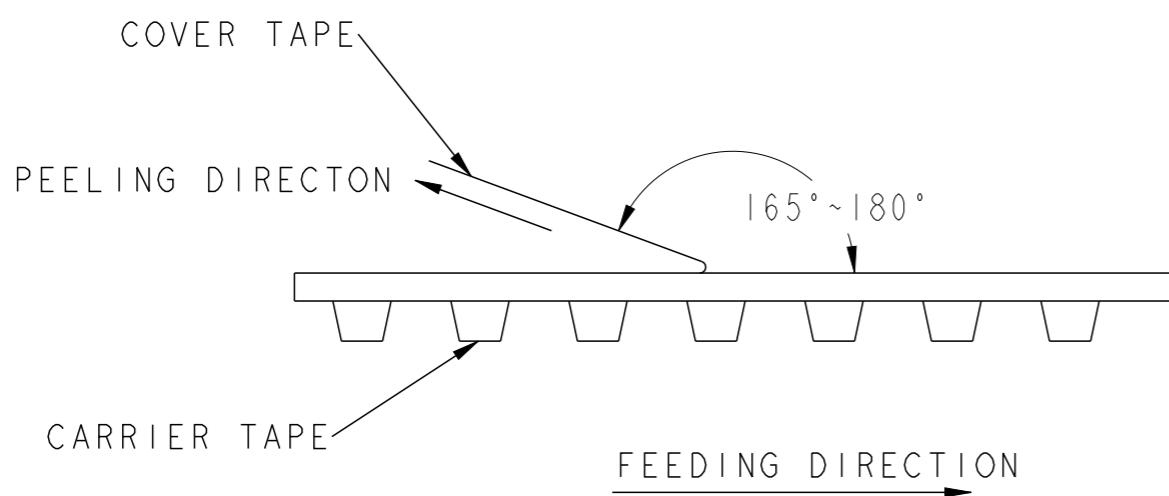
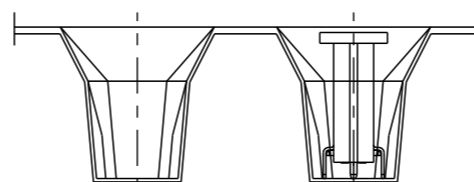

SHOWS THE METHOD OF COVER TAPE'S PEELING FORCE MEASURMENT.
PEELING FORCE MUST BE 0.1 TO 1.3N AT THE SPEED OF 300MM/MIN.

D

D

spec ref	-	dr	Li-Qing Lei	2014/11/20	projection	mm	size	A3	scale	1:1
tolerance std	ISO 406 ISO 1101	eng	Li-Qing Lei	2020/07/24			ecn no	ELX-N-37761-1		
TOLERANCES UNLESS OTHERWISE SPECIFIED		chr	-	-			product family	rel level	Released	
surface	linear	0.X	± 0.25	Amphenol FCI	USB3.1 Type-C		dwg no	10132328		rev
		0.XX	± 0.15		Vertical, Receptacle					
ISO 1302	angular	0°	$\pm 2^\circ$		cat. no.	Product - Customer Drw	sheet 3 of 3			