



American Opto Plus LED Corp.

L955MWC-S

3.5 X 2.8 X 1.9mm PLCC2

MAIN FEATURES:

- Low current requirement
- Wide viewing angle
- IR Reflow Soldering
- I.C. compatible

PACKAGE OUTLINES:

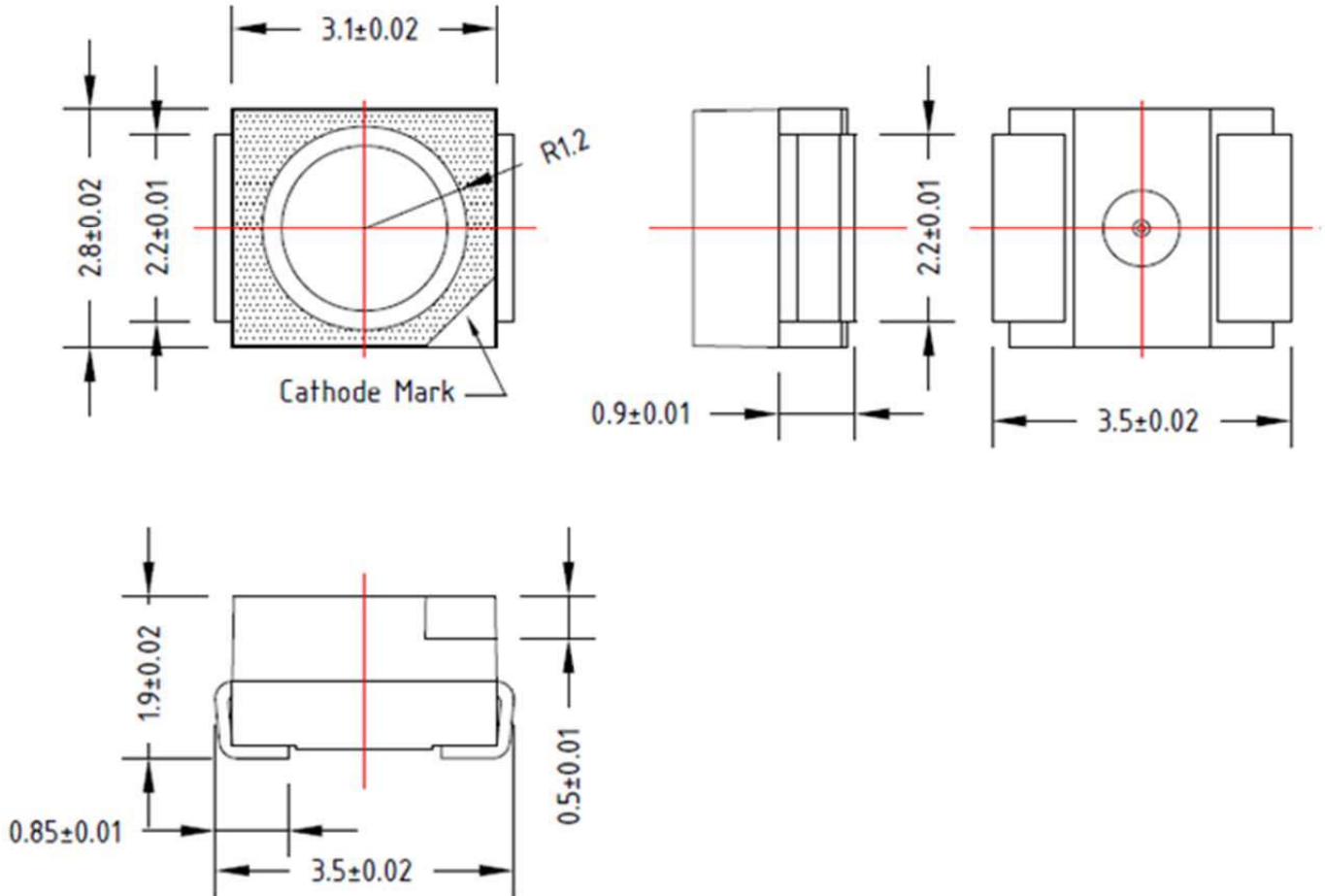

Chip Material	Chip Emitted	Lens Color	Viewing Angle
InGaN	White	Yellow	120

NOTES:

1. All dimensions are in millimeters (inches);
2. Electrical Connection between all Cathodes is Recommended



American Opto Plus LED Corp.

L955MWC-S

3.5 X 2.8 X 1.9mm PLCC2

MAIN FEATURES:

- Low current requirement
- Wide viewing angle
- IR Reflow Soldering
- I.C. compatible

ABSOLUTE MAXIMUM RATINGS

(Ta=25°C)

Parameter	Symbol	Max Rating	Unit
Power Dissipation	P_D	105	mW
Pulse Forward Current (1/8 Duty Cycle @1KHz)	I_{PF}	100	mA
Forward Current	I_F	30	mA
Reverse Voltage	V_R	5	V
Operating Temperature Range	T_{OPR}	-30~+85	°C
Storage Temperature Range	T_{STG}	-40~+100	°C
Solder Temperature	T_{SOL}	265°C for 10 sec	

I_{FP} Conditions: Pulse Width ≤ 10msec and Duty ≤ 1/10

OPTICAL-ELECTRICAL CHARACTERISTICS

Parameter	Symbol	Test Condition	Min	Typ	Max	Unit
Luminous Intensity	I_v	$I_F = 20mA$	1800	2300	2800	mcd
Forward Voltage	V_F	$I_F = 20mA$	-	3.1	3.5	V
Chromaticity Coordinate	X	$I_F = 25mA$	--	0.31	--	
Chromaticity Coordinate	Y	$I_F = 25mA$	--	0.32	--	

Notes: Luminous intensity tolerance is ±10%



American Opto Plus LED Corp.

L955MWC-S

3.5 X 2.8 X 1.9mm PLCC2

MAIN FEATURES:

- Low current requirement
- Wide viewing angle
- IR Reflow Soldering
- I.C. compatible

Luminous Intensity Bin Table

IF=20mA

Rank name	Min (mcd)	Max (mcd)
1	1800	2000
2	2000	2200
3	2200	2400
4	2400	2600
5	2600	2800

Voltage Bin Table

IF=20mA

Rank name	Min (V)	Max (V)
A	2.9	3.0
B	3.0	3.1
C	3.1	3.2
D	3.2	3.3
E	3.3	3.4
F	3.4	3.5

※ Tolerance for each bin limit is $\pm 0.5V$



American Opto Plus LED Corp.

L955MWC-S

3.5 X 2.8 X 1.9mm PLCC2

MAIN FEATURES:

- Low current requirement
- Wide viewing angle
- IR Reflow Soldering
- I.C. compatible

Chromaticity Diagram

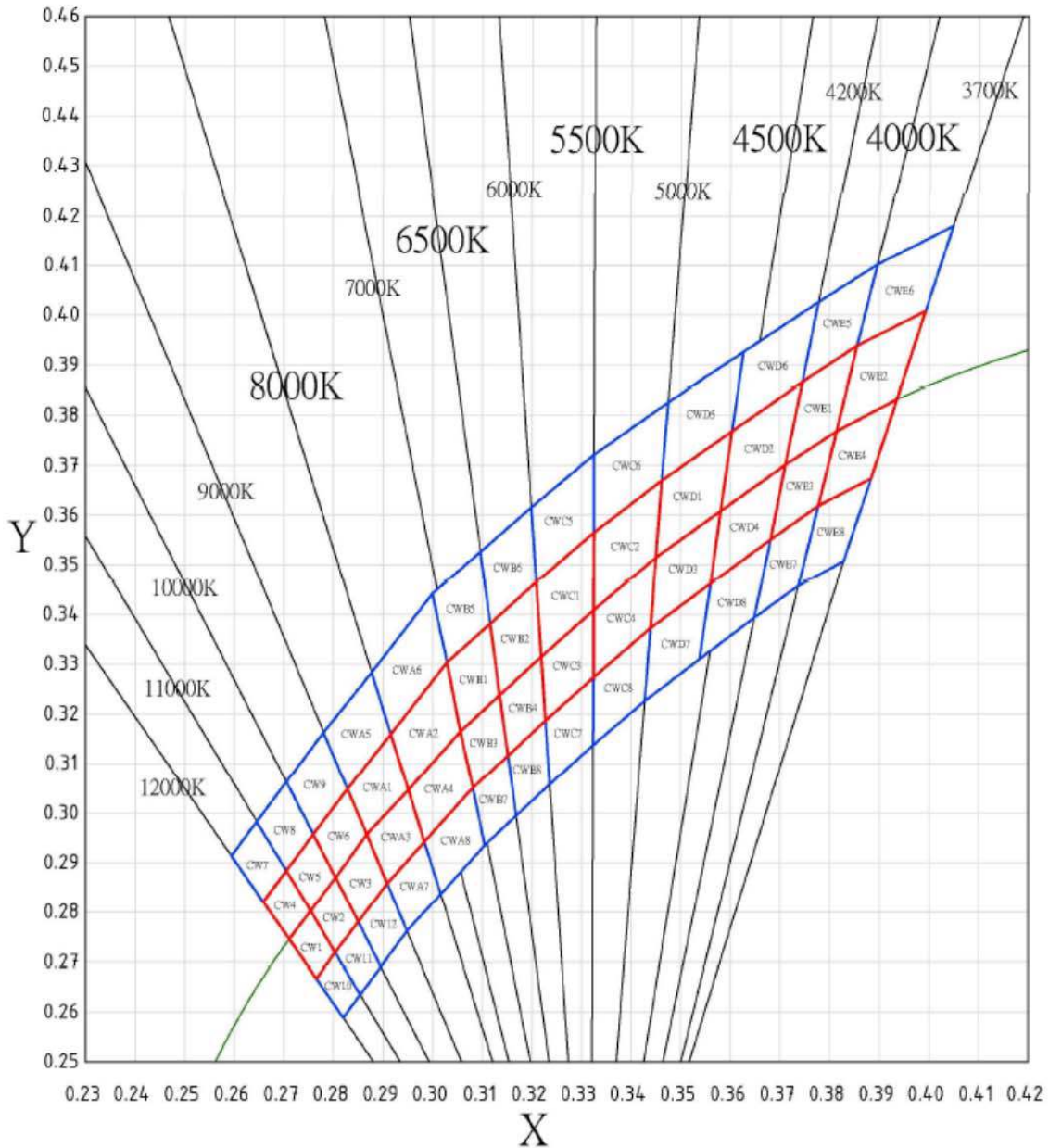



American Opto Plus LED Corp.
L955MWC-S
3.5 X 2.8 X 1.9mm PLCC2

MAIN FEATURES:

- Low current requirement
- Wide viewing angle
- IR Reflow Soldering
- I.C. compatible

Color Ranks

CW 1					CW 2				
x	0.27650	0.27110	0.27540	0.28030	x	0.28030	0.27540	0.28040	0.28500
y	0.26670	0.27460	0.28030	0.27190	y	0.27190	0.28030	0.28700	0.27810
CW 3					CW 4				
x	0.28500	0.28040	0.28670	0.29080	x	0.27110	0.26580	0.27050	0.27540
y	0.27810	0.28700	0.29570	0.28590	y	0.27460	0.28210	0.28840	0.28030
CW 5					CW 6				
x	0.27540	0.27050	0.27590	0.28040	x	0.28040	0.27590	0.28280	0.28670
y	0.28030	0.28840	0.29570	0.28700	y	0.28700	0.29570	0.30490	0.29570
CW 7					CW 8				
x	0.26580	0.25940	0.26450	0.27050	x	0.27050	0.26450	0.27050	0.27590
y	0.28210	0.29140	0.29820	0.28840	y	0.28840	0.29820	0.30630	0.29570
CW 9					CW 10				
x	0.27590	0.27050	0.27800	0.28280	x	0.28190	0.27650	0.28030	0.28540
y	0.29570	0.30630	0.31630	0.30490	y	0.25890	0.26670	0.27190	0.26350
CW 11					CW 12				
x	0.28540	0.28030	0.28500	0.28950	x	0.28950	0.28500	0.29080	0.29480
y	0.26350	0.27190	0.27810	0.26900	y	0.26900	0.27810	0.28590	0.27620
CWA1					CWA2				
x	0.28670	0.28280	0.29150	0.29510	x	0.29510	0.29150	0.30290	0.30570
y	0.29570	0.30490	0.31590	0.30470	y	0.30470	0.31590	0.33040	0.31660
CWA3					CWA4				
x	0.29080	0.28670	0.29510	0.29830	x	0.29830	0.29510	0.30560	0.30810
y	0.28590	0.29570	0.30470	0.29420	y	0.29420	0.30470	0.31650	0.30510
CWA5					CWA6				
x	0.28280	0.27800	0.28770	0.29150	x	0.29150	0.28770	0.29990	0.30290
y	0.30490	0.31630	0.32840	0.31590	y	0.31590	0.32840	0.34420	0.33040
CWA7					CWA8				
x	0.29480	0.29080	0.29830	0.30160	x	0.30160	0.29830	0.30810	0.31050
y	0.27620	0.28590	0.29420	0.28370	y	0.28370	0.29420	0.30510	0.29350
CWB1					CWB2				
x	0.30560	0.30290	0.31160	0.31350	x	0.31350	0.31160	0.32090	0.32190
y	0.31650	0.33040	0.33820	0.32380	y	0.32380	0.33820	0.34650	0.33150



American Opto Plus LED Corp.

L955MWC-S

3.5 X 2.8 X 1.9mm PLCC2

MAIN FEATURES:

- Low current requirement
- Wide viewing angle
- IR Reflow Soldering
- I.C. compatible

CWB3					CWB4				
x	0.30810	0.30570	0.31350	0.31520	x	0.31520	0.31350	0.32190	0.32270
y	0.30510	0.31660	0.32380	0.31160	y	0.31160	0.32380	0.33150	0.31870
CWB5					CWB6				
x	0.30290	0.29990	0.30960	0.31160	x	0.31160	0.30960	0.31990	0.32090
y	0.33040	0.34420	0.35260	0.33820	y	0.33820	0.35260	0.36160	0.34650
CWB7					CWB8				
x	0.31050	0.30810	0.31520	0.31680	x	0.31680	0.31520	0.32270	0.32360
y	0.29350	0.30510	0.31160	0.29950	y	0.29950	0.31160	0.31870	0.30580
CWC1					CWC2				
x	0.32190	0.32090	0.33250	0.33240	x	0.33240	0.33250	0.34620	0.34500
y	0.33150	0.34650	0.35650	0.34090	y	0.34090	0.35650	0.36700	0.35150
CWC3					CWC4				
x	0.32270	0.32190	0.33240	0.33240	x	0.33240	0.33240	0.34500	0.34390
y	0.31870	0.33150	0.34090	0.32740	y	0.32740	0.34090	0.35150	0.33730
CWC5					CWC6				
x	0.32090	0.31990	0.33250	0.33250	x	0.33250	0.33250	0.34750	0.34620
y	0.34650	0.36160	0.37210	0.35650	y	0.35650	0.37210	0.38260	0.36700
CWC7					CWC8				
x	0.32360	0.32270	0.33240	0.33230	x	0.33230	0.33240	0.34390	0.34270
y	0.30580	0.31870	0.32740	0.31370	y	0.31370	0.32740	0.33730	0.32260
CWD1					CWD2				
x	0.34500	0.34620	0.36035	0.35805	x	0.35805	0.36035	0.37450	0.37110
y	0.35150	0.36700	0.37680	0.36080	y	0.36080	0.37680	0.38660	0.37010
CWD3					CWD4				
x	0.34390	0.34500	0.35805	0.35600	x	0.35600	0.35805	0.37110	0.36810
y	0.33730	0.35150	0.36080	0.34620	y	0.34620	0.36080	0.37010	0.35510
CWD5					CWD6				
x	0.34620	0.34750	0.36265	0.36035	x	0.36035	0.36265	0.37780	0.37450
y	0.36700	0.38260	0.39260	0.37680	y	0.37680	0.39260	0.40260	0.38660
CWD7					CWD8				
x	0.34270	0.34390	0.35600	0.35375	x	0.35375	0.35600	0.36810	0.36480
y	0.32260	0.33730	0.34620	0.33100	y	0.33100	0.34620	0.35510	0.33940



American Opto Plus LED Corp.

L955MWC-S

3.5 X 2.8 X 1.9mm PLCC2

MAIN FEATURES:

- Low current requirement
- Wide viewing angle
- IR Reflow Soldering
- I.C. compatible

CWE1					CWE2				
x	0.37110	0.37450	0.38560	0.38140	x	0.38140	0.38560	0.39940	0.39360
y	0.37010	0.38660	0.39390	0.37680	y	0.37680	0.39390	0.40080	0.38320
CWE3					CWE4				
x	0.36810	0.37110	0.38140	0.37770	x	0.37770	0.38140	0.39360	0.38840
y	0.35510	0.37010	0.37680	0.36190	y	0.36190	0.37680	0.38320	0.36740
CWE5					CWE6				
x	0.37450	0.37780	0.38970	0.38560	x	0.38560	0.38970	0.40500	0.39940
y	0.38660	0.40260	0.41020	0.39390	y	0.39390	0.41020	0.41800	0.40080
CWE7					CWE8				
x	0.36480	0.36810	0.37770	0.37370	x	0.37370	0.37770	0.38840	0.38280
y	0.33940	0.35510	0.36190	0.34580	y	0.34580	0.36190	0.36740	0.35070

Note

1. One delivery will include several color ranks and I_v ranks of products.
The quantity-ratio of the different rank is decided by AOP
2. Color Coordinates Measurement Allowance is ± 0.01
3. 2000 pcs per reel.



American Opto Plus LED Corp.

L955MWC-S

3.5 X 2.8 X 1.9mm PLCC2

MAIN FEATURES:

- Low current requirement
- Wide viewing angle
- IR Reflow Soldering
- I.C. compatible

OPTICAL CHARACTERISTIC CURVES:

Forward Current vs. Forward Voltage

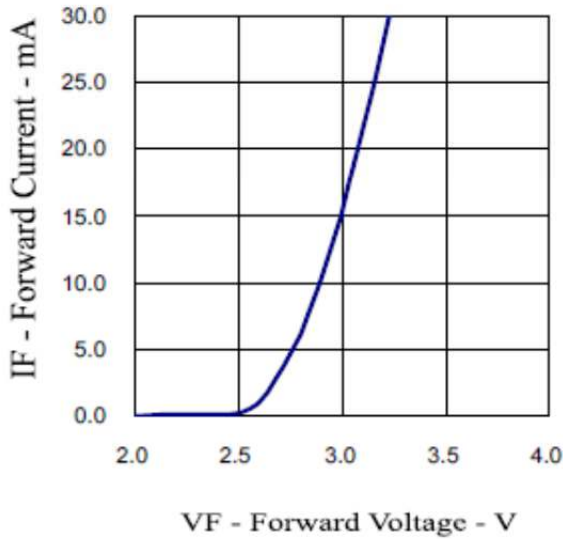

Relative Intensity vs. Forward Current

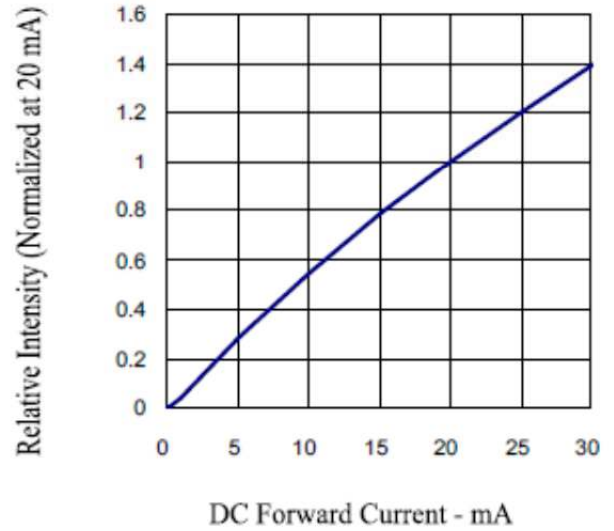

Forward Current vs. Ambient Temperature

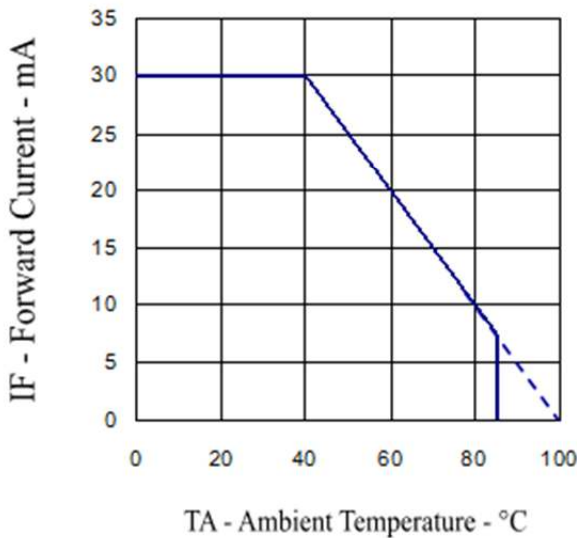

Relative Intensity vs. Wavelength

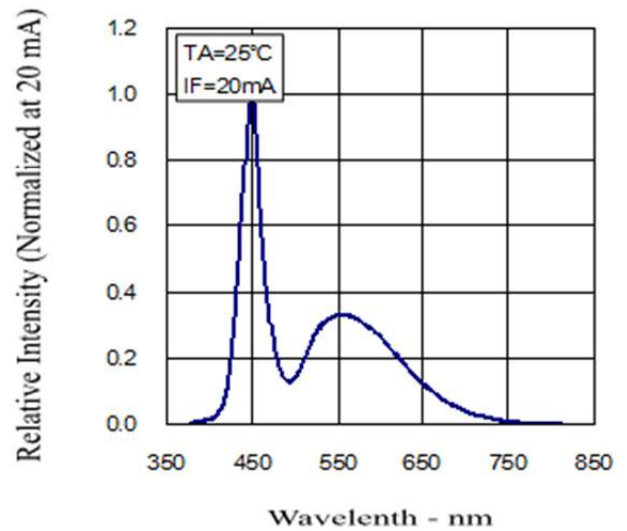



American Opto Plus LED Corp.

L955MWC-S

3.5 X 2.8 X 1.9mm PLCC2

MAIN FEATURES:

- Low current requirement
- Wide viewing angle
- IR Reflow Soldering
- I.C. compatible

Radiation Pattern

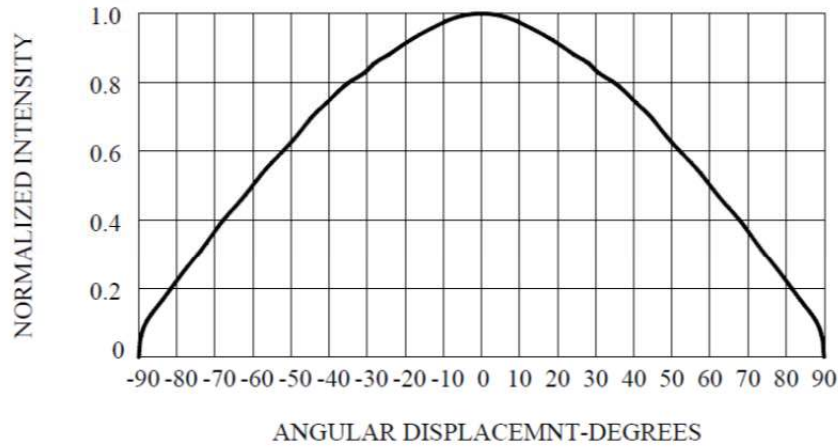

Recommended Soldering Pad Pattern

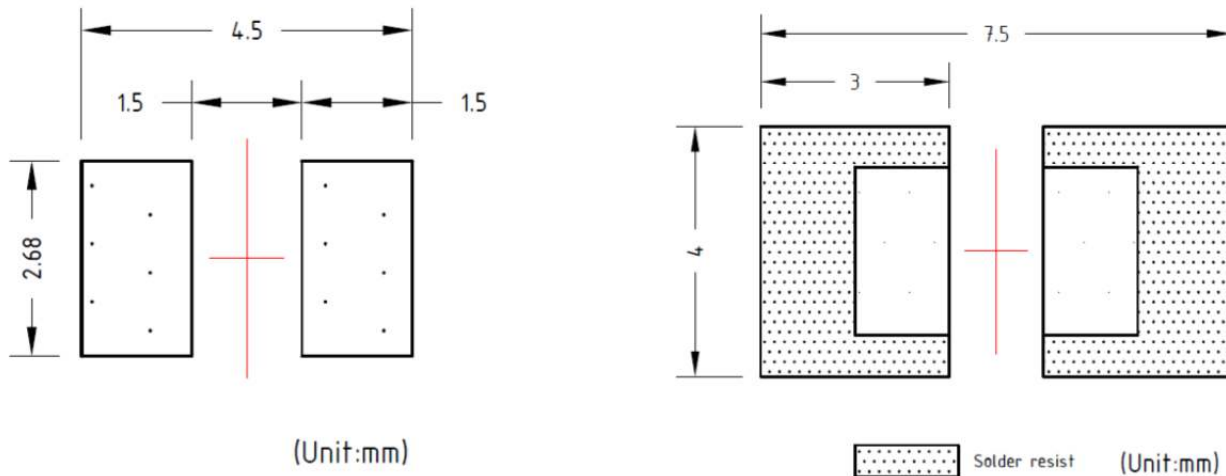



American Opto Plus LED Corp.
L955MWC-S
3.5 X 2.8 X 1.9mm PLCC2

MAIN FEATURES:

- Low current requirement
- Wide viewing angle
- IR Reflow Soldering
- I.C. compatible

Soldering Conditions:

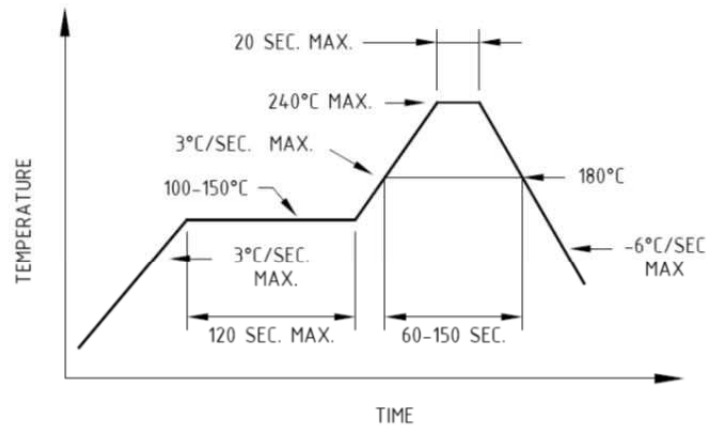

Recommended reflow soldering profile

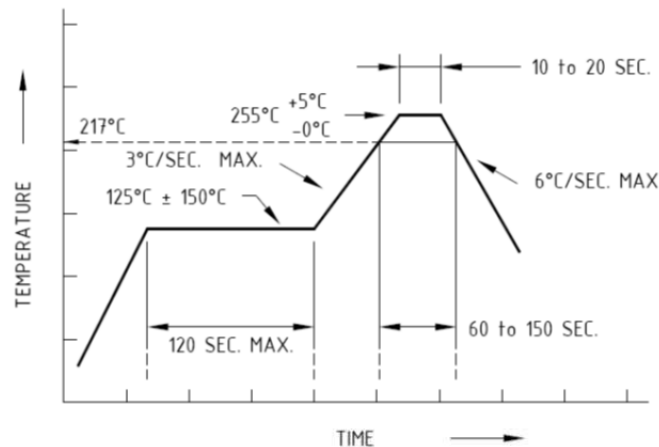

Recommended Pb-free reflow soldering profile

- Repairing should not be done after the LEDs have been soldered. When repairing is unavoidable, a double-head soldering iron should be used. It should be confirmed beforehand whether the characteristics of the LEDs will or will not be damaged by repairing.
- Reflow soldering should not be done more than two times.
- When soldering, do not put stress on the LEDs during heating.
- After soldering, do not warp the circuit board.



American Opto Plus LED Corp.

L955MWC-S

3.5 X 2.8 X 1.9mm PLCC2

MAIN FEATURES:

- Low current requirement
- Wide viewing angle
- IR Reflow Soldering
- I.C. compatible

Tape Dimension

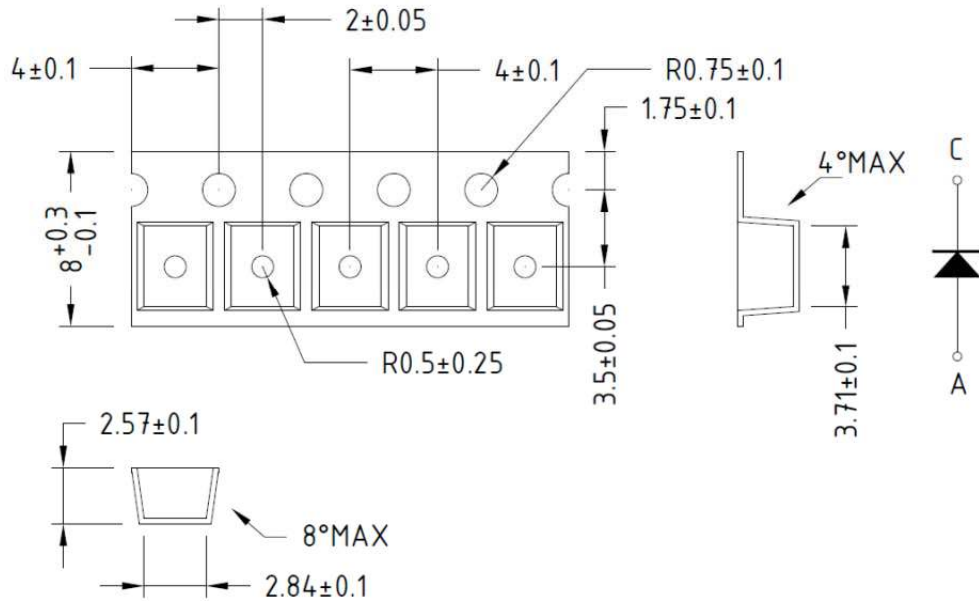

Tape Leader and Trailer Dimension

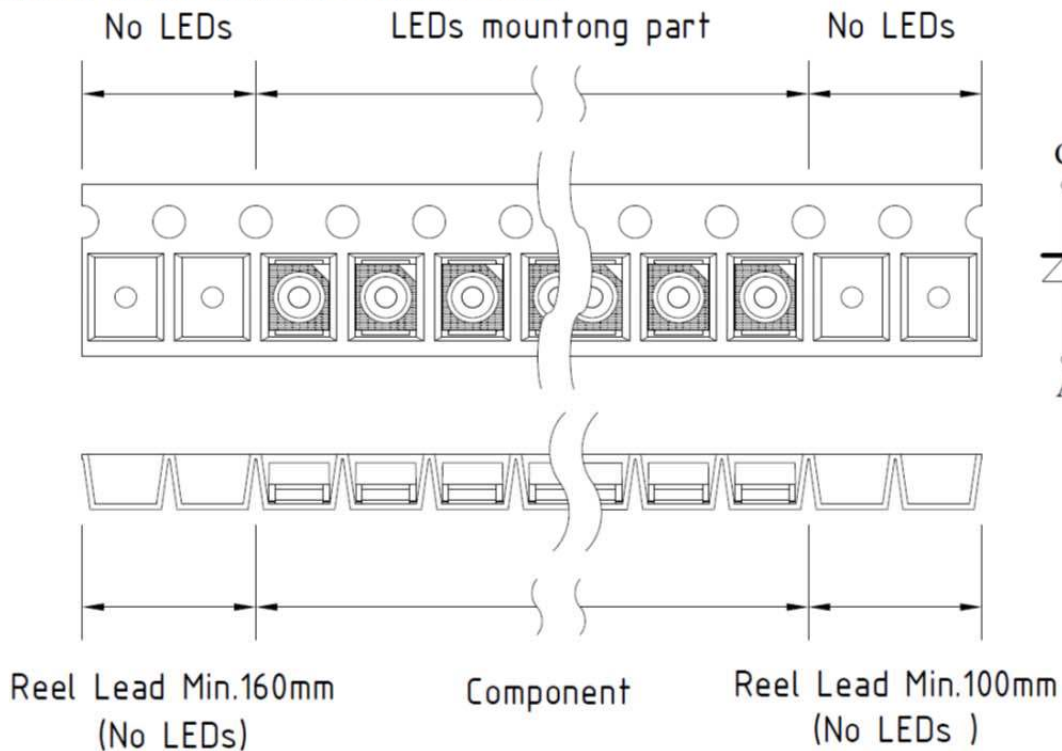

USER FEED DIRECTION



American Opto Plus LED Corp.

L955MWC-S

3.5 X 2.8 X 1.9mm PLCC2

MAIN FEATURES:

- Low current requirement
- Wide viewing angle
- IR Reflow Soldering
- I.C. compatible

Reel Dimension

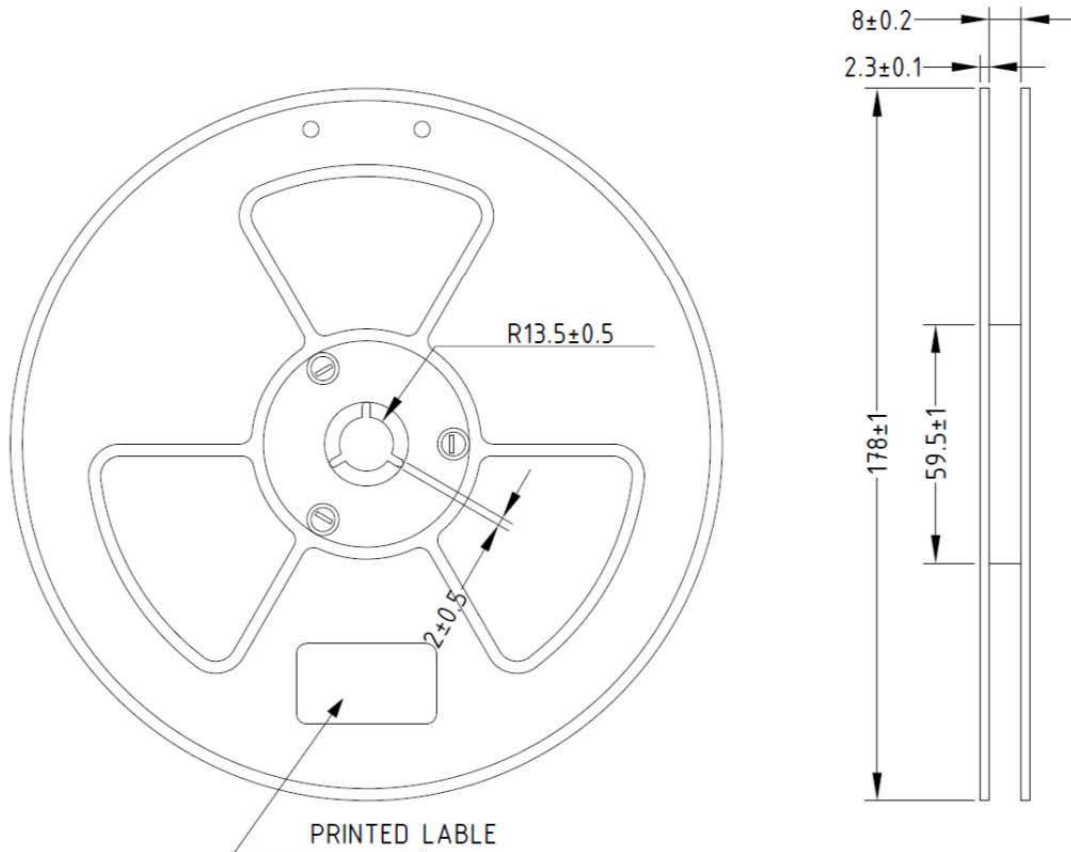

Note: Baking is required under the following conditions:

The pack has been opened for more than four weeks.

Baking recommended conditions:

60 ± 5 °C for 20 hours.



American Opto Plus LED Corp.

L955MWC-S

3.5 X 2.8 X 1.9mm PLCC2

MAIN FEATURES:

- Low current requirement
- Wide viewing angle
- IR Reflow Soldering
- I.C. compatible

Moisture Sensitivity

AOP's SMD LED are shipped in sealed, moisture-barrier bags (MBB) designed for long shelf life. If SMD LED has exposed with moist environments before soldering, this may cause damage to SMD LED during soldering (reflow) operation.

Storage / Floor Time

Condition	Temperature(C)	Humidity(RH)	Period of Time
Before Open	30	60	1 year from shipping date
After Open	30	60	Within 72 hours

- MSL of this product are MSL4, please see IPC/JEDEC STD020D for more detail.
- LEDs reach floor time may be damaged while soldering/reflow processing, please bake the LEDs before use.
- If RH indicator card show 60% RH when unseal the package, please bake/discard the LED.

Reseal

- AOP's aluminum MBB may reuse as to reseal the unused LED of MBB has not damaged or had any holes in it.
- Moisture absorbent material (silica gel) may be reuse if it does not become pink.
- Proper resealed LED's floor time will NOT RESET, only stop counting until open.
- If RH indicator card show 60% RH when open the package, please bake/discard the LED.

Baking

Condition	Temperature(C)	Period of Time
With Reel	60	More then 24 hours, but not more then 48 hours
Without Reel	90	24 hours

- Baking of LED available ONCE only, more than once may damage the LEDs while baking.
- Baking only required when LED reach it's floor time.