



ENV Unit with Temperature Humidity Pressure Sensor (DHT12+BMP280)

SKU:U001

ENV is a environment sensor, can be used for temperature, humidity, and atmospheric pressure measurement. Build with DHT12 and BMP280.

DHT12 is a upgradation version of DHT11 humidity temperature sensor, fully downward compatible, more precise and add I2C interface. BMP280 is an absolute barometric pressure sensor especially designed for mobile applications, offers highest flexibility to optimize the device regarding power consumption, resolution and filter performance.

Product Features

- Temperature:
 - measuring range: -20 ~ 60 °C
 - resolution: $\pm 0.2^{\circ}\text{C}$
- Humidity:
 - measuring range: 20 ~ 95 %RH
 - resolution: 0.1%
- Air pressure
 - measuring range: 300 ~ 1100hPa
 - resolution: $\pm 1\text{hPa}$
- Program Platform: Arduino, UIFlow(Blockly,Python)
- Two Lego-compatible holes

Kit includes

- 1x ENV Unit
- 1x Grove Cable

Learn

Example

1. Arduino IDE

This is a ENV example, implemented reading temperature, humidity and atmospheric pressure function. 1, Before compiling, please install [Adafruit BMP280 Library 2](#), copy `Adafruit_Sensor.h` to `C:\Users\<user_name>\Documents\Arduino\libraries\Adafruit_BMP280_Library`

The code below is incomplete. To get the complete code, please click [here](#).

```
/*
   Install Adafruit BMP280 Library first.
*/
#include <M5Stack.h>
#include "DHT12.h"
#include <Wire.h> //The DHT12 uses I2C comunication.
#include <Adafruit_Sensor.h>
#include <Adafruit_BMP280.h>

// new two objects
DHT12 dht12;
Adafruit_BMP280 bme;

// initialization
M5.begin();
```

```
Wire.begin();
bmp.begin();

// read data
float tmp = dht12.readTemperature();
float hum = dht12.readHumidity();
float pressure = bme.readPressure();
```

To get the complete code, please click [here](#).

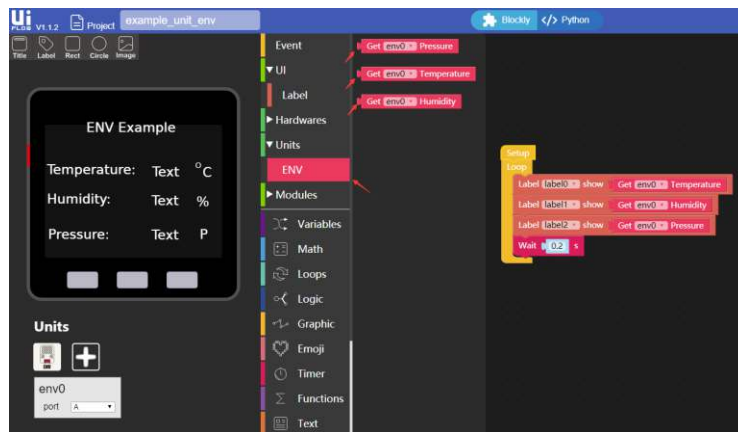

Schematic

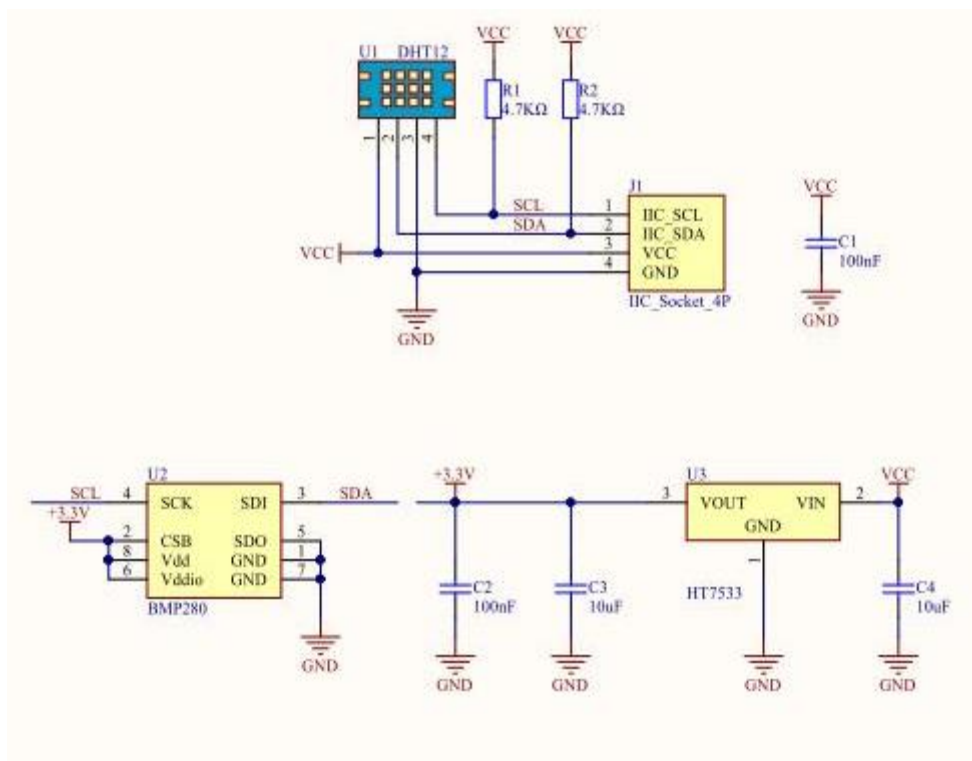

PinMap

M5Core(GROVE A)	GPIO22	GPIO21	5V	GND
ENV Unit	SCL	SDA	5V	GND

