

SN54LS440 THRU SN54LS442, SN54LS444 SN74LS440 THRU SN74LS442, SN74LS444 QUADRUPLE TRIDIRECTIONAL BUS TRANSCEIVERS

SDLS176 – AUGUST 1979 – REVISED MARCH 1988

- 3-Way Asynchronous Communication
- On-Chip Bus Selection Decoding
- Input Hysteresis Improves Noise Margin
- Choice of Open-Collector or 3-State Outputs

description

These bus transceivers are designed for asynchronous three-way communication between four-line data buses. They give the designer a choice of selecting inverting, noninverting, or a combination of inverting and noninverting data paths with either 3-state or open-collector outputs.

The S0 and S1 inputs select the bus from which data are to be transferred. The \bar{G} inputs enable the bus or buses to which data are to be transferred. The port for any bus selected for input and any other bus not enabled for output will be at high impedance including those of the open-collector devices.

The SN54LS440 through SN54LS442 and SN54LS444 are characterized for operation over the fullmilitary temperature range of -55°C to 125°C . The SN74LS440 through SN74LS442 and SN74LS444 are characterized for operation from 0°C to 70°C .

FUNCTION TABLE

INPUTS						TRANSFERS BETWEEN BUSES		
\bar{CS}	S1	S0	$\bar{G}A$	$\bar{G}B$	$\bar{G}C$	'LS440 'LS442	'LS441	'LS444
H	X	X	X	X	X	None	None	None
X	H	H	X	X	X	None	None	None
X	X	X	H	H	H	None	None	None
X	L	L	X	H	H	None	None	None
X	L	H	H	X	H	None	None	None
X	H	L	H	H	X	None	None	None
L	L	L	X	L	L	$A \rightarrow B, A \rightarrow C$	$\bar{A} \rightarrow B, \bar{A} \rightarrow C$	$\bar{A} \rightarrow B, \bar{A} \rightarrow C$
L	L	H	L	X	L	$B \rightarrow C, B \rightarrow A$	$\bar{B} \rightarrow C, \bar{B} \rightarrow A$	$B \rightarrow C, \bar{B} \rightarrow A$
L	H	L	L	L	X	$C \rightarrow A, C \rightarrow B$	$\bar{C} \rightarrow A, \bar{C} \rightarrow B$	$\bar{C} \rightarrow A, C \rightarrow B$
L	L	L	X	L	H	$A \rightarrow B$	$\bar{A} \rightarrow B$	$\bar{A} \rightarrow B$
L	L	H	H	X	L	$B \rightarrow C$	$\bar{B} \rightarrow C$	$B \rightarrow C$
L	H	L	L	H	X	$C \rightarrow A$	$\bar{C} \rightarrow A$	$\bar{C} \rightarrow A$
L	L	L	X	H	L	$A \rightarrow C$	$\bar{A} \rightarrow C$	$\bar{A} \rightarrow C$
L	L	H	L	X	H	$B \rightarrow A$	$\bar{B} \rightarrow A$	$\bar{B} \rightarrow A$
L	H	L	H	L	X	$C \rightarrow B$	$\bar{C} \rightarrow B$	$C \rightarrow B$

SN54LS' . . . J PACKAGE
SN74LS' . . . DW OR N PACKAGE
(TOP VIEW)

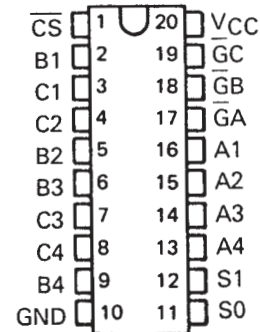

SN54LS' . . . FK PACKAGE
(TOP VIEW)

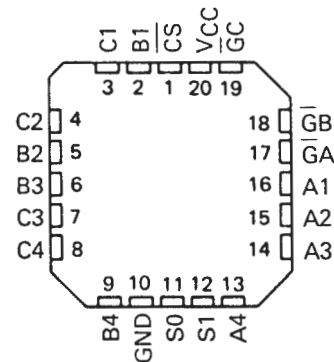

DEVICE	OUTPUT	LOGIC
'LS440	Open-Collector	True
'LS441	Open-Collector	Inverting
'LS442	3-State	True
'LS444	3-State	True/Inverting

SN54LS440 THRU SN54LS442, SN54LS444 SN74LS440 THRU SN74LS442, SN74LS444 QUADRUPLE TRIDIRECTIONAL BUS TRANSCEIVERS

SDLS176 – AUGUST 1979 – REVISED MARCH 1988

logic symbols†

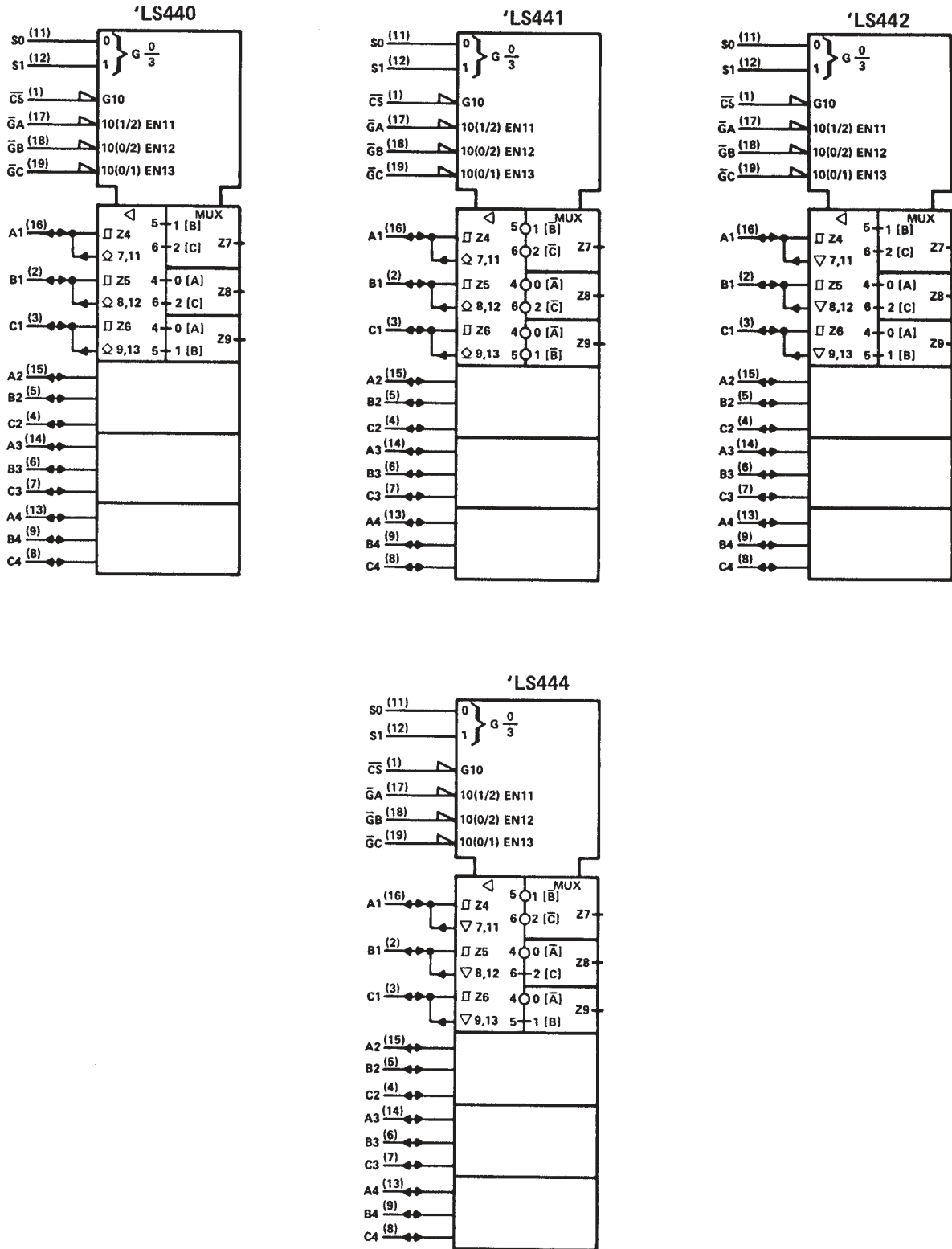

† These symbols are in accordance with ANSI/IEEE Std 91-1984 and IEC Publication 617-12.
Pin numbers shown are for DW, J, and N packages.

SN54LS440 THRU SN54LS442, SN54LS444 SN74LS440 THRU SN74LS442, SN74LS444 QUADRUPLE TRIDIRECTIONAL BUS TRANSCEIVERS

SDLS176 – AUGUST 1979 – REVISED MARCH 1988

logic diagram (composite showing one of four transceivers from each type, positive logic)

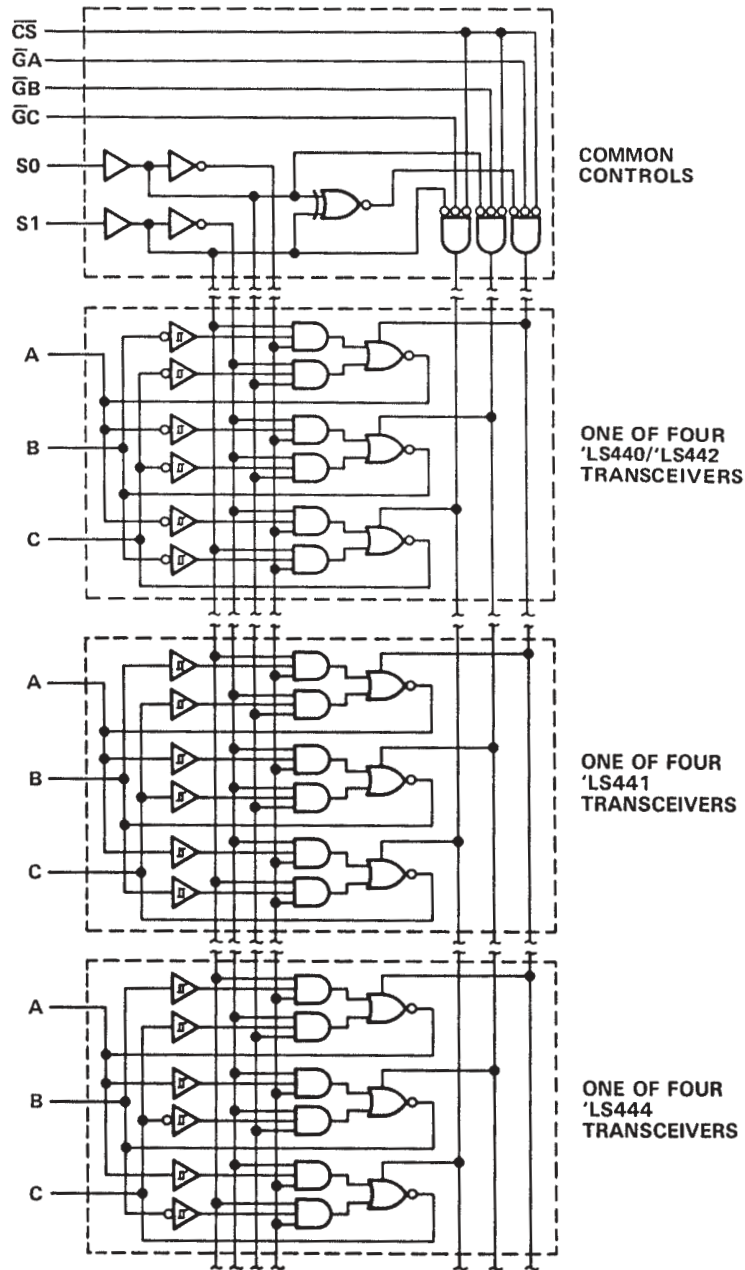

absolute maximum ratings over operating free-air temperature range (unless otherwise noted)

Supply voltage, V_{CC} (see Note 1)	7 V
Input voltage	7 V
Off-state output voltage	5.5 V
Operating free-air temperature range: SN54LS'	-55°C to 125°C
SN74LS'	0°C to 70°C
Storage temperature range	-65°C to 150°C

NOTE 1: Voltage values are with respect to network ground terminal.



POST OFFICE BOX 655303 • DALLAS, TEXAS 75265

SN54LS440 THRU SN54LS442, SN54LS444 SN74LS440 THRU SN74LS442, SN74LS444 QUADRUPLE TRIDIRECTIONAL BUS TRANSCEIVERS

SDLS176 – AUGUST 1979 – REVISED MARCH 1988

recommended operating conditions

	SN54LS440 SN54LS441			SN74LS440 SN74LS441			UNIT
	MIN	NOM	MAX	MIN	NOM	MAX	
Supply voltage, V_{CC} (see Note 1)	4.5	5	5.5	4.75	5	5.25	V
High-level output voltage, V_{OH}			5.5			5.5	V
Low-level output current, I_{OL}			12			24	mA
Operating free-air temperature, T_A	-55		125	0		70	C

NOTE 1: Voltage values are with respect to the network ground terminal.

electrical characteristics over recommended operating free-air temperature range (unless otherwise noted)

PARAMETER	TEST CONDITIONS†	SN54LS'			SN74LS'			UNIT	
		MIN	TYP‡	MAX	MIN	TYP‡	MAX		
V_{IH} High-level input voltage		2			2			V	
V_{IL} Low-level input voltage				0.5			0.6	V	
V_{IK} Input clamp voltage	$V_{CC} = \text{MIN}, I_I = -18 \text{ mA}$			-1.5			-1.5	V	
Hysteresis ($V_{T+} - V_{T-}$) A,B,C input	$V_{CC} = \text{MIN}$	0.1	0.4		0.2	0.4		V	
I_{OH} High-level output current	$V_{CC} = \text{MIN}, V_{OH} = 5.5 \text{ V}, V_{IH} = 2 \text{ V}, V_{IL} = V_{ILmax}$			100			100	μA	
V_{OL} Low-level output voltage	$V_{CC} = \text{MIN}, V_{IH} = 2 \text{ V}, V_{IL} = V_{ILmax}$	$I_{OL} = 12 \text{ mA}$	0.25	0.4	0.25	0.4		V	
		$I_{OL} = 24 \text{ mA}$			0.35	0.5		V	
I_I Input current at maximum input voltage	A,B,C input	$V_{CC} = \text{MAX}$	$V_I = 5.5 \text{ V}$				0.1	mA	
	All others		$V_I = 7 \text{ V}$				0.1		
I_{IH} High-level input current	$V_{CC} = \text{MAX}, V_I = 2.7 \text{ V}$			20			20	μA	
I_{IL} Low-level input current	$V_{CC} = \text{MAX}, V_I = 0.4 \text{ V}$			-0.4			-0.4	mA	
I_{CC} Supply current	Outputs low	$V_{CC} = \text{MAX},$ Outputs open		62	90		62	90	mA
	Outputs disabled			64	95		64	95	

† For conditions shown as MIN or MAX, use the appropriate value specified under recommended operating conditions.

‡ All typical values are at $V_{CC} = 5 \text{ V}, T_A = 25^\circ\text{C}$.

switching characteristics at $V_{CC} = 5 \text{ V}, R_L = 667 \Omega, C_L = 45 \text{ pF}, T_A = 25^\circ\text{C}$, see note 2

PARAMETER	FROM (INPUT)	TO (OUTPUT)	'LS440			'LS441			UNIT
			MIN	TYP	MAX	MIN	TYP	MAX	
t_{PLH} Propagation delay time, low-to-high level output	A	B		24	35		21	30	ns
	A	C		24	35		21	30	
	B	A		24	35		21	30	
	B	C		24	35		21	30	
	C	A		24	35		21	30	
	C	B		24	35		21	30	
t_{PHL} Propagation delay time, high-to-low level output	A	B		20	30		9	15	ns
	A	C		20	30		9	15	
	B	A		20	30		9	15	
	B	C		20	30		9	15	
	C	A		20	30		9	15	
	C	B		20	30		9	15	
t_{PLH} Propagation delay time, low-to-high level output	Any \bar{G}	A,B,C		29	45		23	35	ns
	S0,S1	A,B,C		33	50		27	40	
	\bar{CS}	A,B,C		31	45		26	40	
t_{PHL} Propagation delay time, high-to-low level output	Any \bar{G}	A,B,C		27	40		20	30	ns
	S0,S1	A,B,C		32	50		26	40	
	\bar{CS}	A,B,C		28	45		21	30	

NOTE 2: Load circuits and voltage waveforms are shown in Section 1.



SN54LS440 THRU SN54LS442, SN54LS444 SN74LS440 THRU SN74LS442, SN74LS444 QUADRUPLE TRIDIRECTIONAL BUS TRANSCEIVERS

SDLS176 – AUGUST 1979 – REVISED MARCH 1988

recommended operating conditions

	SN54LS442 SN54LS444			SN74LS442 SN74LS444			UNIT
	MIN	NOM	MAX	MIN	NOM	MAX	
Supply voltage, V_{CC} (see Note 1)	4.5	5	5.5	4.75	5	5.25	V
High-level output current, I_{OH}			-12			-15	mA
Low-level output current, I_{OL}			12			24	mA
Operating free-air temperature, T_A	-55		125	0		70	°C

NOTE 1: Voltage values are with respect to the network ground terminal.

electrical characteristics over recommended operating free-air temperature range (unless otherwise noted)

PARAMETER		TEST CONDITIONS†	SN54LS'			SN74LS'			UNIT
			MIN	TYP‡	MAX	MIN	TYP‡	MAX	
V_{IH}	High-level input voltage		2			2			V
V_{IL}	Low-level input voltage		0.5			0.6			V
V_{IK}	Input clamp voltage	$V_{CC} = \text{MIN}, I_I = -18 \text{ mA}$	-1.5			-1.5			V
	Hysteresis ($V_{T+} - V_{T-}$)	A, B, C input $V_{CC} = \text{MIN}$	0.1	0.4		0.2	0.4		V
V_{OH}	High-level output voltage	$V_{CC} = \text{MIN},$ $V_{IH} = 2 \text{ V},$ $V_{IL} = V_{IL\text{max}}$	$I_{OH} = -3 \text{ mA}$	2.4	3.4	2.4	3.4		V
			$I_{OH} = \text{MAX}$	2		2			
V_{OL}	Low-level output voltage	$V_{CC} = \text{MIN},$ $V_{IH} = 2 \text{ V},$ $V_{IL} = V_{IL\text{max}}$	$I_{OL} = 12 \text{ mA}$	0.25	0.4	0.25	0.4		V
			$I_{OL} = 24 \text{ mA}$			0.35	0.5		
I_{OZH}	Off-state output current, high-level voltage applied	$V_{CC} = \text{MAX},$ \overline{CS} at 2 V	$V_O = 2.7 \text{ V}$	20		20		μA	
I_{OZL}	Off-state output current, low-level voltage applied		$V_O = 0.4 \text{ V}$	-400		-400			
I_I	Input current at maximum input voltage	A, B, C Others $V_{CC} = \text{MAX}$	$V_I = 5.5 \text{ V}$	0.1		0.1		mA	
			$V_I = 7 \text{ V}$	0.1		0.1			
I_{IH}	High-level input current	$V_{CC} = \text{MAX},$ $V_I = 2.7 \text{ V}$	20		20		μA		
I_{IL}	Low-level input current	$V_{CC} = \text{MAX},$ $V_I = 0.4 \text{ V}$	-0.4		-0.4		mA		
I_{OS}	Short circuit output current §	$V_{CC} = \text{MAX}$	-40	-225	-40	-225	mA		
I_{CC}	Supply current	$V_{CC} = \text{MAX},$ Outputs open	Outputs low	62	90	62	90	mA	
			Outputs at Hi-Z	64	95	64	95		

† For conditions shown as MIN or MAX, use the appropriate value specified under recommended operating conditions.

‡ All typical values are at $V_{CC} = 5 \text{ V}, T_A = 25^\circ\text{C}$.

§ Not more than one output should be shorted at a time, and duration of the short circuit should not exceed one second.

SN54LS440 THRU SN54LS442, SN54LS444 SN74LS440 THRU SN74LS442, SN74LS444 QUADRUPLE TRIDIRECTIONAL BUS TRANSCEIVERS

SDLS176 – AUGUST 1979 – REVISED MARCH 1988

switching characteristics at $V_{CC} = 5\text{ V}$, $T_A = 25^\circ\text{C}$, see note 2

PARAMETER	FROM (INPUT)	TO (OUTPUT)	TEST CONDITIONS	'LS442			'LS444			UNIT
				MIN	TYP	MAX	MIN	TYP	MAX	
t_{PLH} Propagation delay time, low-to-high level output	A	B	$C_L = 45\text{ pF}$, $R_L = 667\ \Omega$		10	14		9	14	ns
	A	C			10	14		9	14	
	B	A			10	14		9	14	
	B	C			10	14		10	14	
	C	A			10	14		9	14	
	C	B			10	14		10	14	
t_{PHL} Propagation delay time, high-to-low level output	A	B			13	20		7	13	ns
	A	C			13	20		7	13	
	B	A			13	20		7	13	
	B	C			13	20		13	20	
	C	A			13	20		7	13	
	C	B			13	20		13	20	
t_{PZL} Output enable time to low level	Any \overline{G}	A,B,C		22	33		22	33	ns	
	S0,S1	A,B,C		28	42		28	42		
	\overline{CS}	A,B,C		23	36		23	36		
t_{PZH} Output enable time to high level	\overline{G} , S, \overline{CS}	A,B,C		21	32		24	32	ns	
t_{PLZ} Output disable time from low level	\overline{G} , S, \overline{CS}	A,B,C	$C_L = 5\text{ pF}$, $R_L = 667\ \Omega$		14	35		14	25	ns
t_{PHZ} Output disable time from high level	\overline{G} , S, \overline{CS}	A,B,C			14	25		14	25	ns

NOTE 2: Load circuits and voltage waveforms are shown in Section 1.

schematics of inputs and outputs

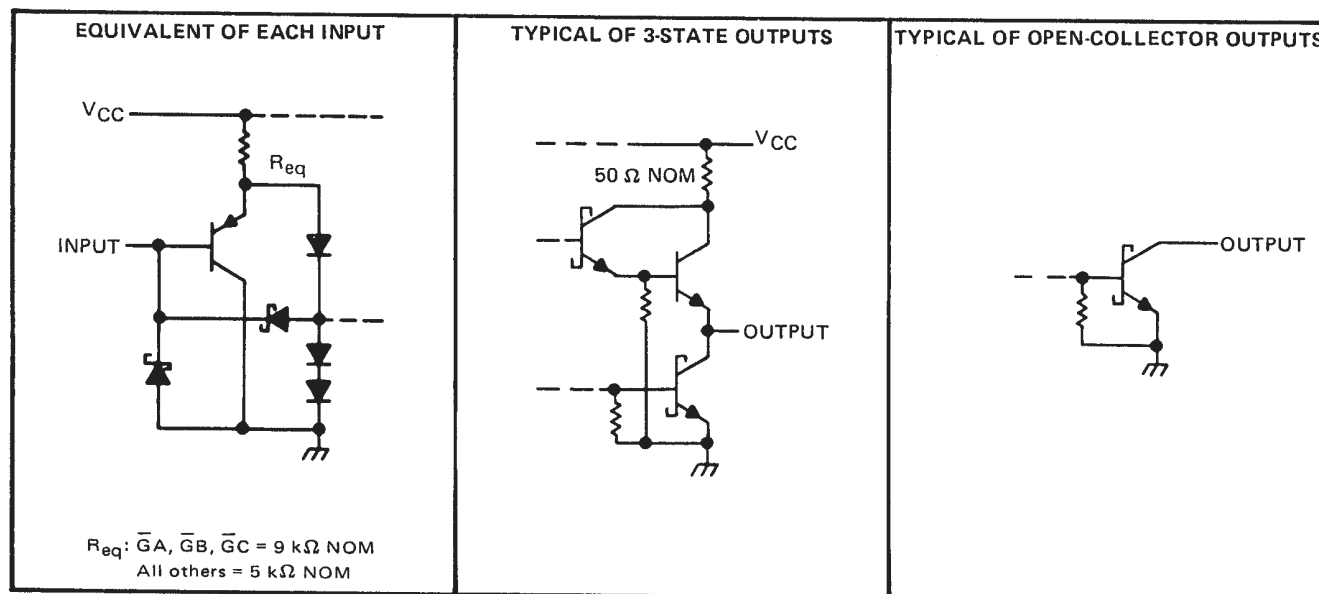

IMPORTANT NOTICE

Texas Instruments and its subsidiaries (TI) reserve the right to make changes to their products or to discontinue any product or service without notice, and advise customers to obtain the latest version of relevant information to verify, before placing orders, that information being relied on is current and complete. All products are sold subject to the terms and conditions of sale supplied at the time of order acknowledgement, including those pertaining to warranty, patent infringement, and limitation of liability.

TI warrants performance of its semiconductor products to the specifications applicable at the time of sale in accordance with TI's standard warranty. Testing and other quality control techniques are utilized to the extent TI deems necessary to support this warranty. Specific testing of all parameters of each device is not necessarily performed, except those mandated by government requirements.

CERTAIN APPLICATIONS USING SEMICONDUCTOR PRODUCTS MAY INVOLVE POTENTIAL RISKS OF DEATH, PERSONAL INJURY, OR SEVERE PROPERTY OR ENVIRONMENTAL DAMAGE ("CRITICAL APPLICATIONS"). TI SEMICONDUCTOR PRODUCTS ARE NOT DESIGNED, AUTHORIZED, OR WARRANTED TO BE SUITABLE FOR USE IN LIFE-SUPPORT DEVICES OR SYSTEMS OR OTHER CRITICAL APPLICATIONS. INCLUSION OF TI PRODUCTS IN SUCH APPLICATIONS IS UNDERSTOOD TO BE FULLY AT THE CUSTOMER'S RISK.

In order to minimize risks associated with the customer's applications, adequate design and operating safeguards must be provided by the customer to minimize inherent or procedural hazards.

TI assumes no liability for applications assistance or customer product design. TI does not warrant or represent that any license, either express or implied, is granted under any patent right, copyright, mask work right, or other intellectual property right of TI covering or relating to any combination, machine, or process in which such semiconductor products or services might be or are used. TI's publication of information regarding any third party's products or services does not constitute TI's approval, warranty or endorsement thereof.