

LOC	DIST	REVISIONS					
GP	00	P	LTN	DESCRIPTION	DATE	DWN	APVD
		A		ACTIVE THE DRAWING	03JAN2014	ZJ	JY
		B		REVISE PER ECO-15-000289	8JAN2015	RG	MC
		B1		ADD 2170567-6 AND 2170567-7	3MAY2015	RG	SH

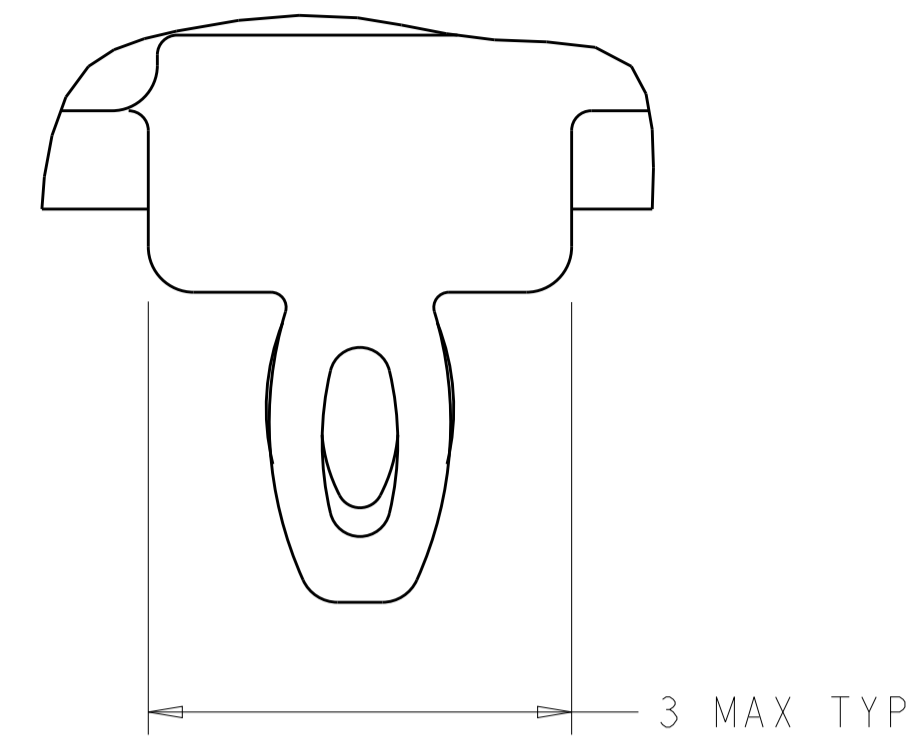

DETAIL S
SCALE 20:1

- 1 CAGE ASSEMBLY MATERIAL: NICKEL SILVER, 0.25 THICK
HEAT SINK MATERIAL: ALUMINUM
HEAT SINK CLIP MATERIAL: STAINLESS STEEL
EMI SPRING MATERIAL: COPPER ALLOY
FRONT FLANGE MATERIAL: ZINC ALLOY
LIGHT PIPE MATERIAL: CLEAR POLYCARBONATE
- 2 PITCH BETWEEN PORTS OF ONE 1X4 CAGE ASSEMBLY.
- 3 SPACING BETWEEN CAGES ON THE SAME PC BOARD, TO BE SPECIFIED BY CUSTOMER, MUST COMPLY WITH MINIMUM DIMENSIONS SHOWN.
- 4 REFERENCE APPLICATION SPEC 114-13218 FOR RECOMMENDED DRILL HOLE DIAMETER AND PLATING THICKNESS.
- 5 DATUMS AND BASIC DIMENSIONS ESTABLISHED BY CUSTOMER.
- 6 DIMENSION F IS THE NOMINAL THICKNESS OF CUSTOMER SUPPLIED PC BOARD,
SINGLE SIDED PC BOARD MINIMUM THICKNESS = 1.45mm
DOUBLE SIDED PC BOARD MINIMUM THICKNESS = 2.2mm PER QSFP.
- 7 HEAT SINKS, LIGHT PIPES, AND HEAT SINK CLIPS SHIPPED ASSEMBLED TO CAGE ASSEMBLY. CAGE ASSEMBLY MAY BE PRESSED INTO THE PCB AS SHIPPED.
- 8 DATUM -A- IS TOP SURFACE OF PC BOARD.
- 9 DIMENSION APPLIES WITH MODULE INSERTED IN CAGE.
- 10 UNPLATED THRU HOLE.
- 11. MATES WITH QSFP MSA COMPATIBLE TRANSCEIVER.
- 12 SURFACE TRACES PERMITTED WITHIN THIS AREA EXCEPT WHERE CAGE STANDOFFS, SHOWN IN DETAIL S, CONTACT PC BOARD.
- 13 BASELINE FOR THESE DIMENSIONS IS THE CENTER OF COMPLIANT PIN HOLE.
- 14 2D BARCODE AND DATE CODE (YYWW) MARKED ON SIDE OF CAGE.

- 15 REFERENCE APP SPEC 114-13218 FOR GASKET THICKNESS CALCULATION.
- 16 EMI SPRING FINISH: 2µm MINIMUM TIN
FRONT FLANGE FINISH: 3µm MINIMUM TIN OVER 1.27µm MINIMUM NICKEL OVER 5.08µm MINIMUM COPPER.
HEAT SINK FINISH: BLACK ANODIZE PROCESS

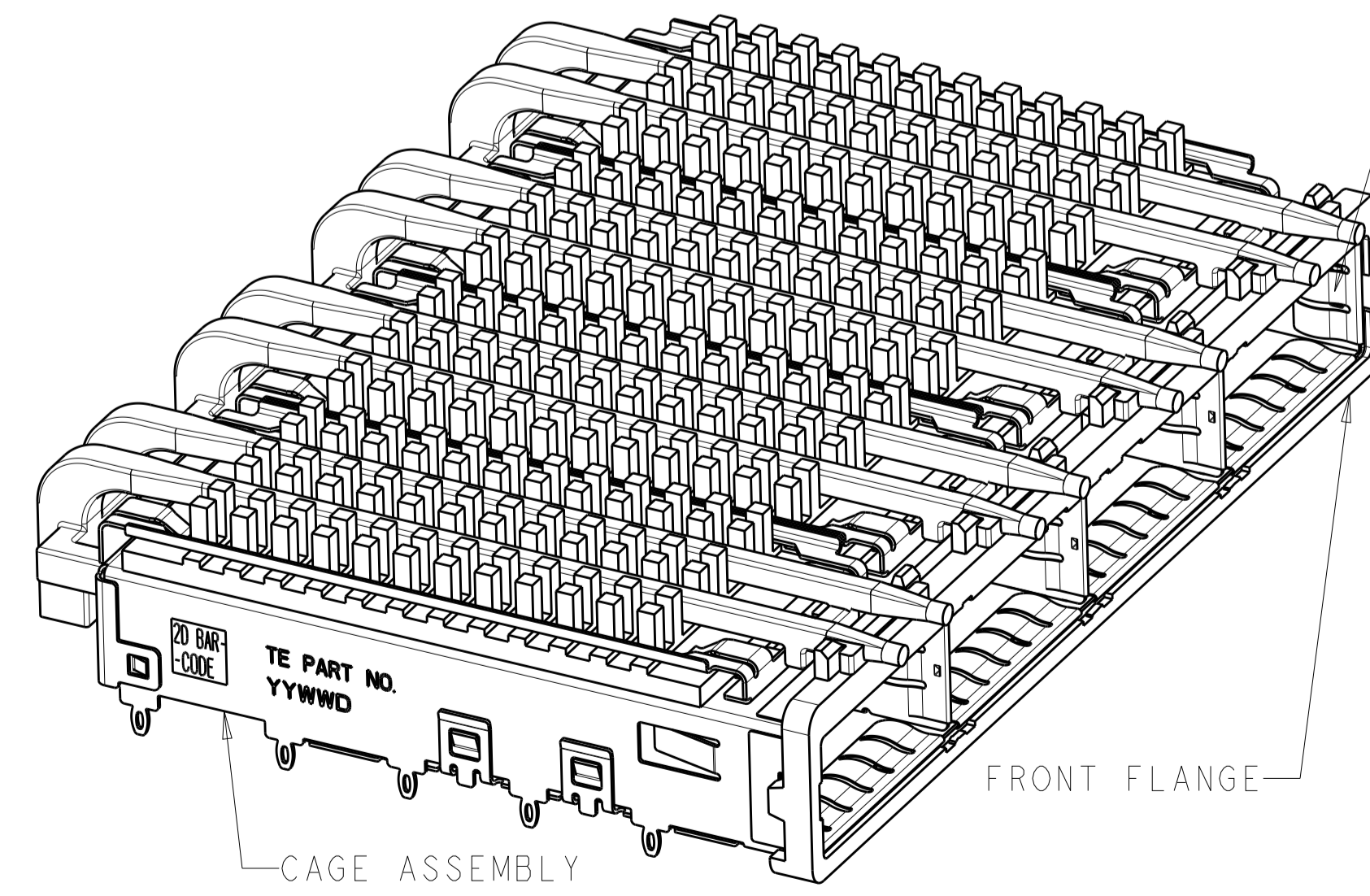
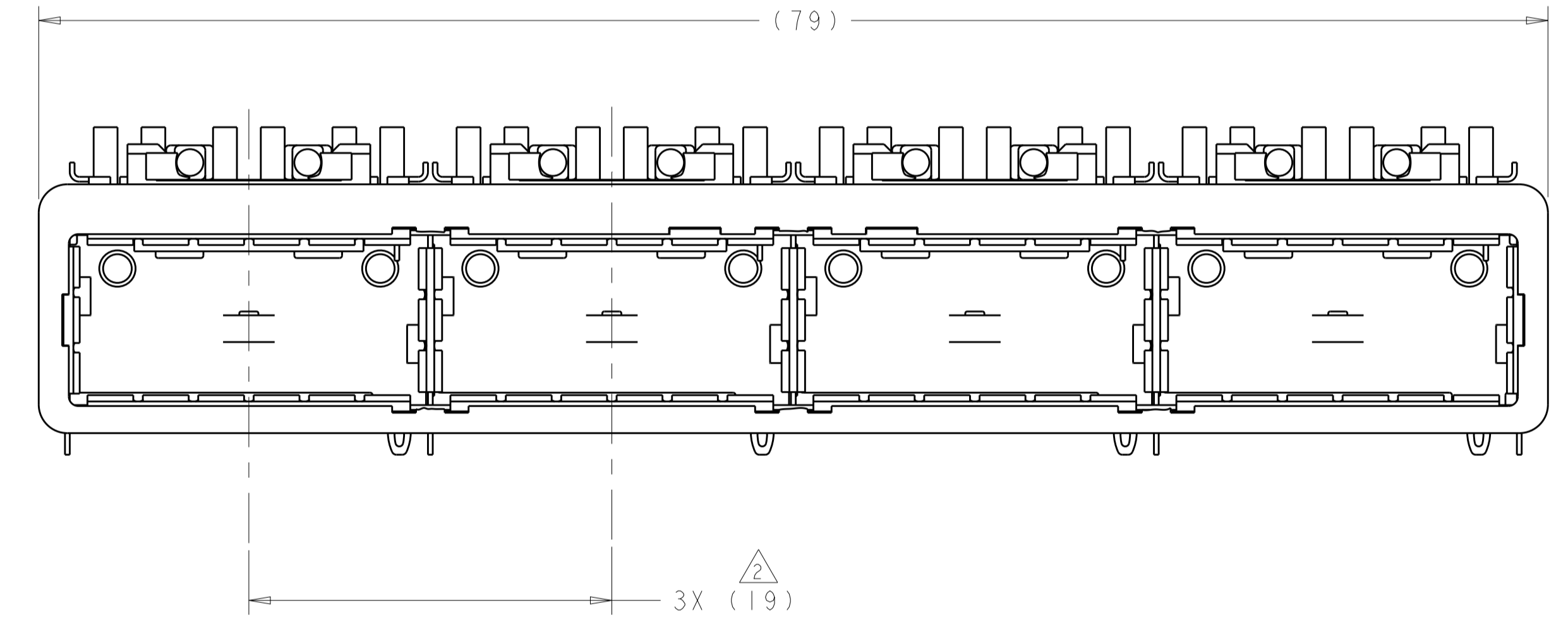
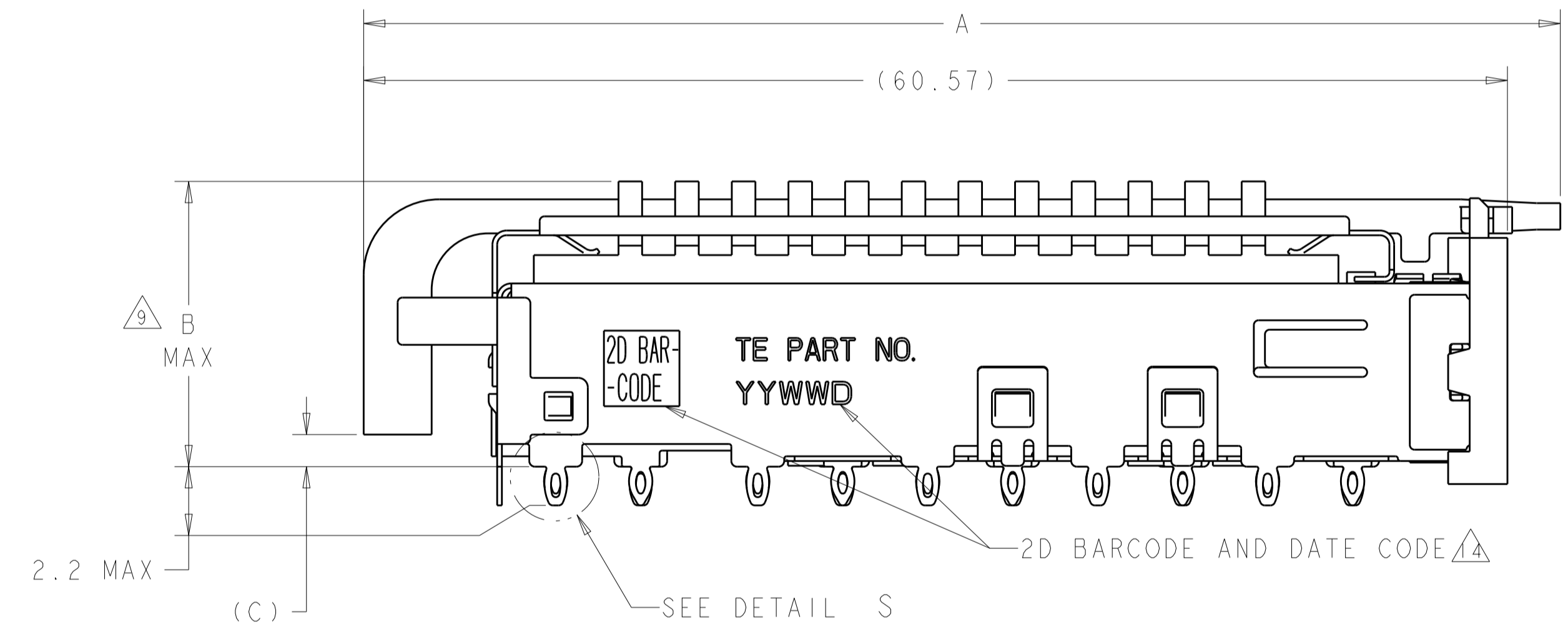

2170567-3
SCALE 5:2

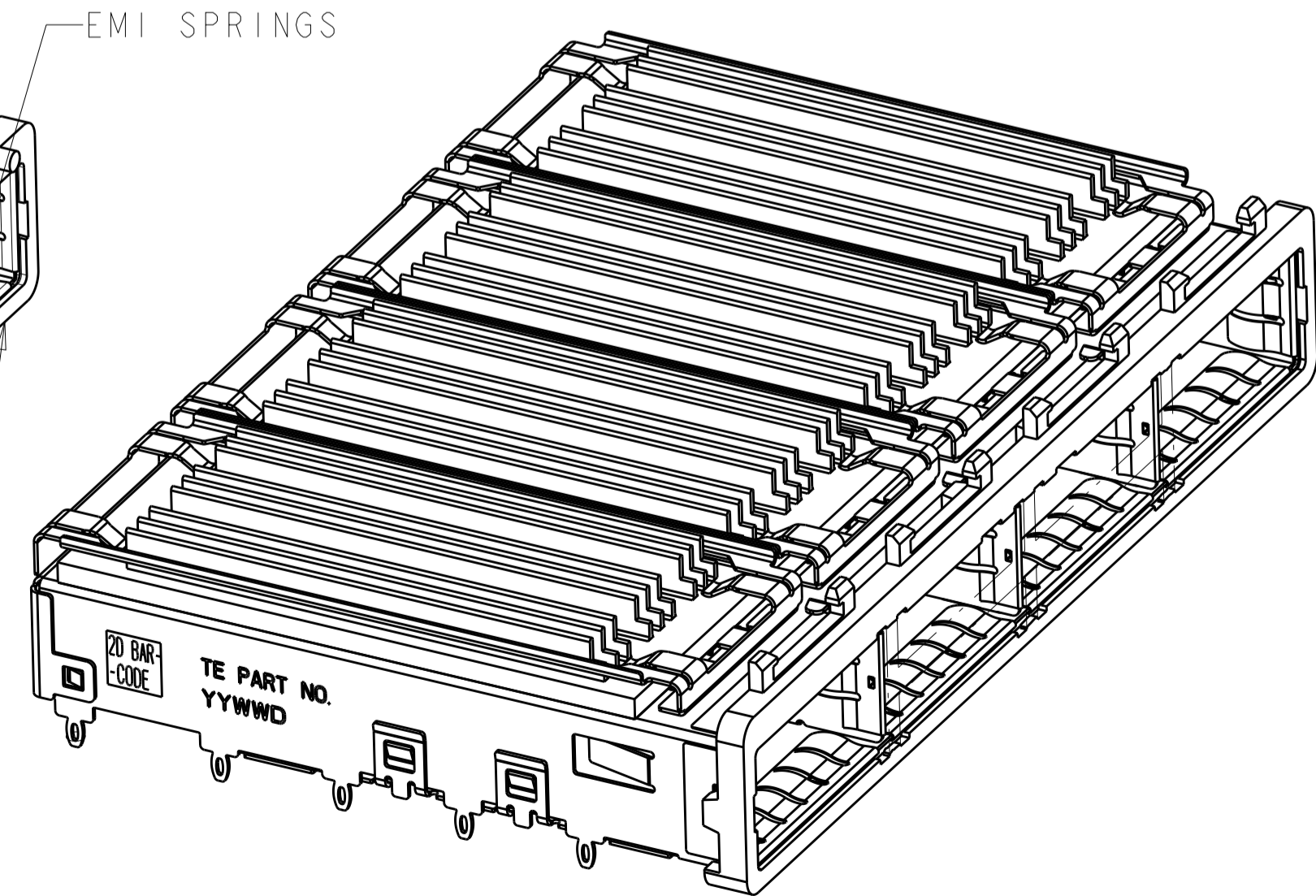

2170567-6
SCALE 5:2

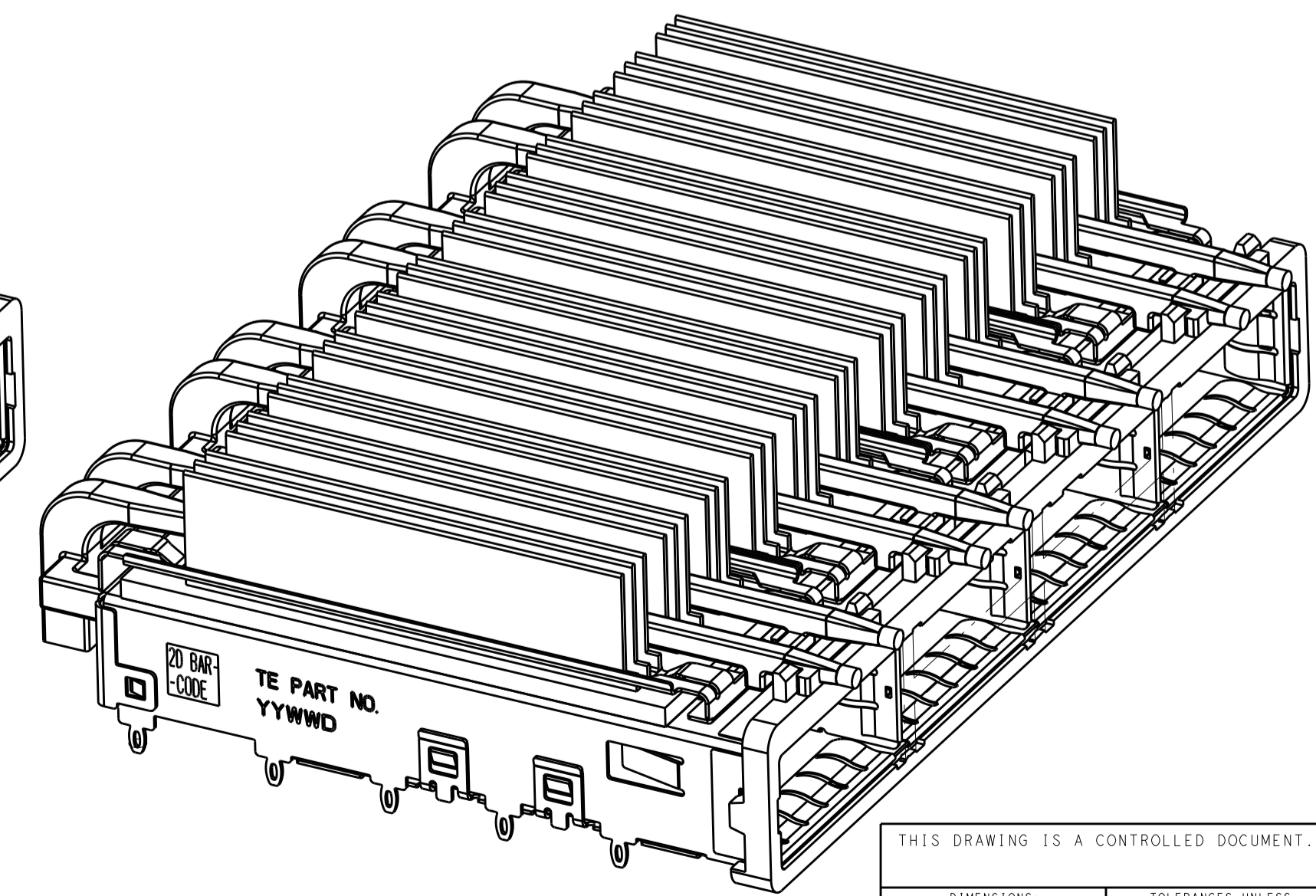

2170567-7
SCALE 5:2

A	B	HEAT SINK PROFILE	PART NUMBER
62.57	21.0	CUSTOMIZED	2170567-7
N/A	15.0	CUSTOMIZED	2170567-6
62.15	16.8	CUSTOMIZED	2170567-5
64.07	23.0	NETWORKING	2170567-4
64.07	16.0	SAN	2170567-3
64.07	16.8	CUSTOMIZED	2170567-2
64.07	13.7	PCI	2170567-1

THIS DRAWING IS A CONTROLLED DOCUMENT.

DIMENSIONS: mm

TOLERANCES UNLESS OTHERWISE SPECIFIED:

0 PLC	±
1 PLC	±0.1
2 PLC	±0.1
3 PLC	±
4 PLC	±
ANGLES	±

MATERIAL: 1

FINISH: 16

Customer Drawing

DWN: ZJ
CHK: JASON
APVD: AC

DATE: 01JUL2013

PRODUCT SPEC: 108-2286

APPLICATION SPEC: 114-13218

WEIGHT: -

Customer Drawing

SCALE: 4:1

SHEET 1 OF 5

REV: B1

TE Connectivity

NAME: 1X4 CAGE ASSEMBLY, BEHIND BEZEL, W/ LIGHT PIPES AND HEAT SINKS, QSFP

SIZE: A1

DRAWING NO: C=2170567

LOC		DIST		REVISIONS			
GP	00	P	LYR	DESCRIPTION	DATE	OWN	APVD
		-		SEE SHEET 1			

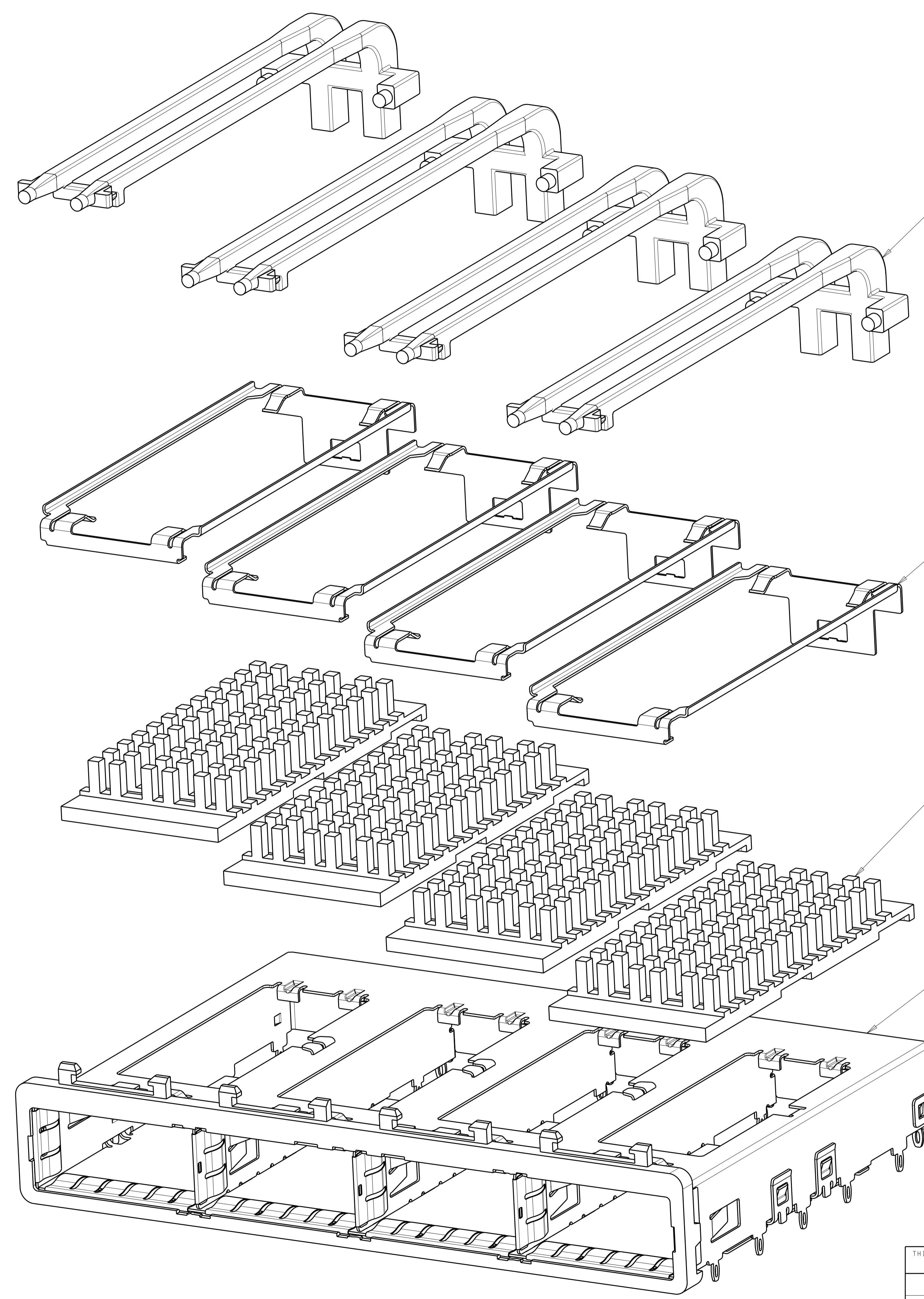

DOUBLE LIGHT PIPES \triangle
 QUANTITY: 4

HEAT SINK CLIPS \triangle
 QUANTITY: 4

72 PIN HEAT SINKS \triangle
 QUANTITY: 4

1X4 BEHIND BEZEL QSFP
 CAGE ASSEMBLY
 QUANTITY: 1

THIS DRAWING IS A CONTROLLED DOCUMENT.		OWN	01JUN13	STE TE Connectivity
		CHK	01JUL13	
		APVD	01JUL13	NAME 1X4 CAGE ASSEMBLY, BEHIND BEZEL, W/ LIGHT PIPES AND HEAT SINKS, QSFP
		AC		
DIMENSIONS:		TOLERANCES UNLESS OTHERWISE SPECIFIED:		PRODUCT SPEC 108-2286
mm		0 PLC \pm		
		1 PLC ± 0.1		APPLICATION SPEC 114-13218
		2 PLC ± 0.1		
		3 PLC \pm		RESTRICTED TO
		4 PLC \pm		
		ANGLES \pm		SIZE CAGE CODE DRAWING NO
MATERIAL		FINISH		A1 - C=2170567
				Customer Drawing
				SCALE 4:1 SHEET 2 OF 5 REV B1

LOC	DIST	REV	DATE	BY	APPD
GP	00				

REVISIONS			
REV	DATE	BY	APPD
-	-	-	-
-	-	-	-

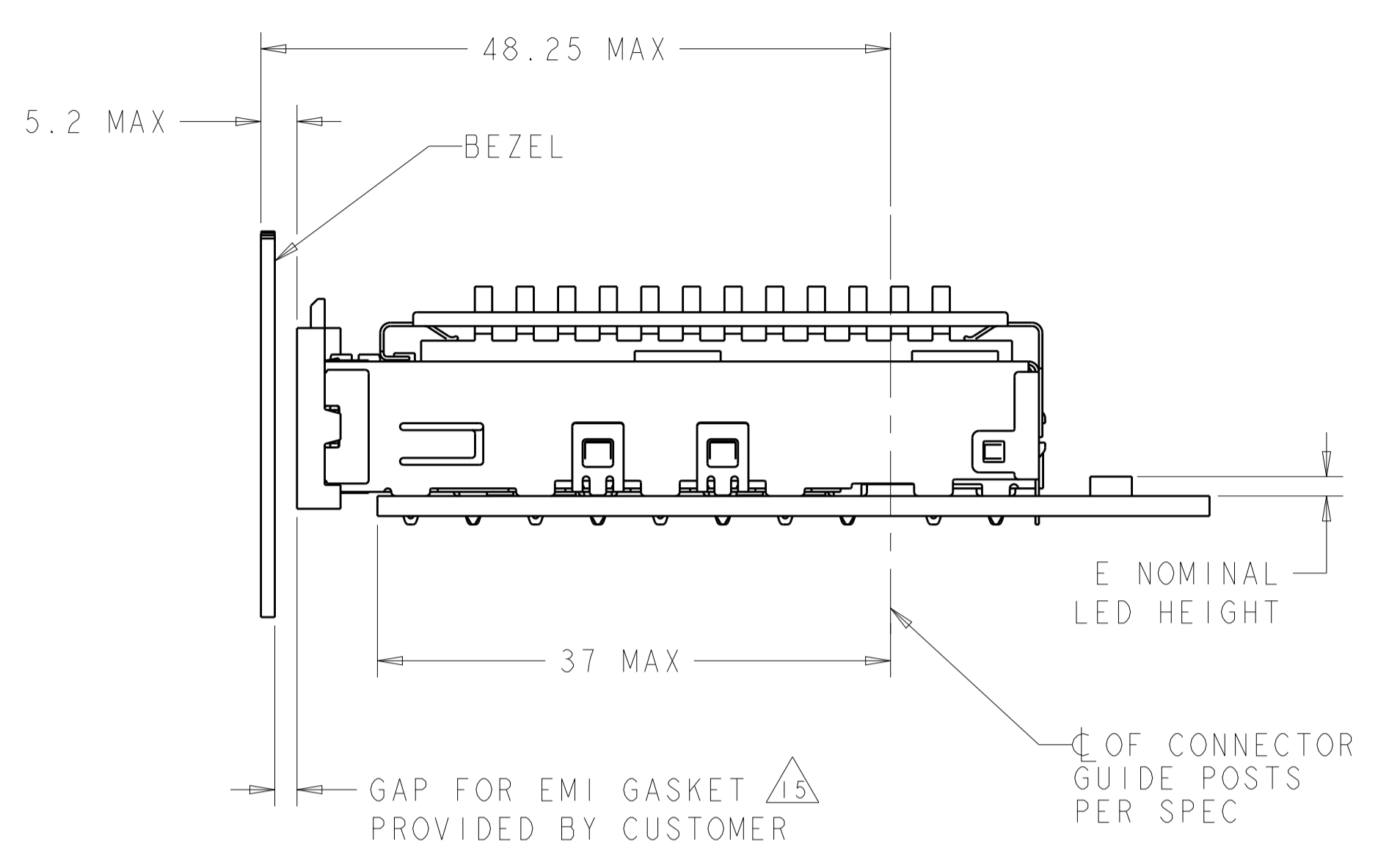
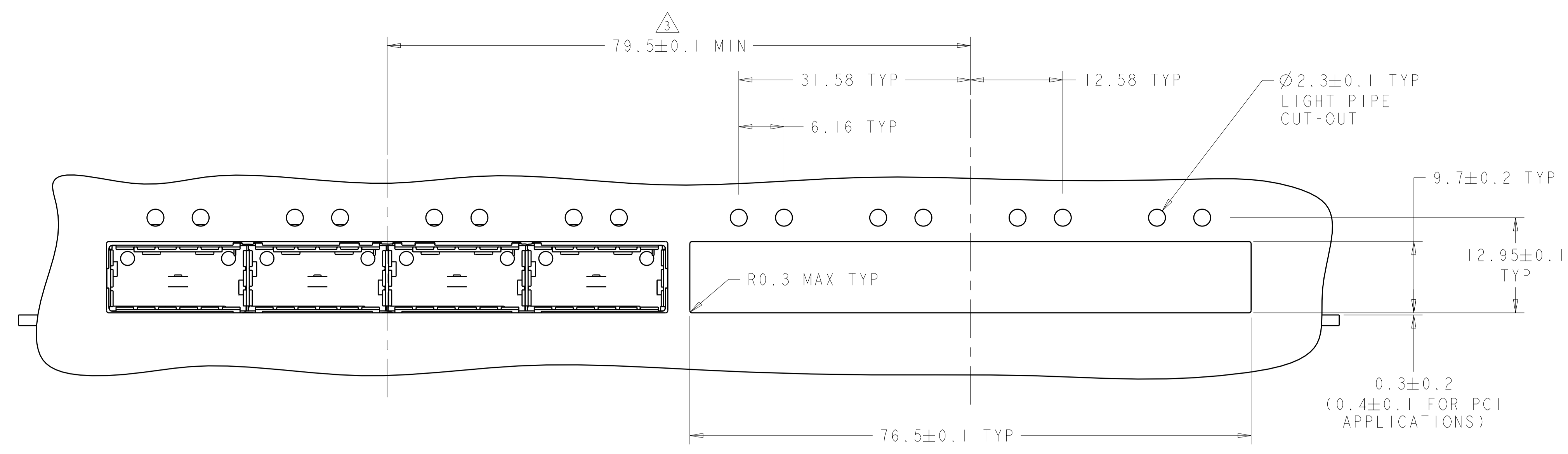

ONE SIDED CONFIGURATION
 SCALE 5:2

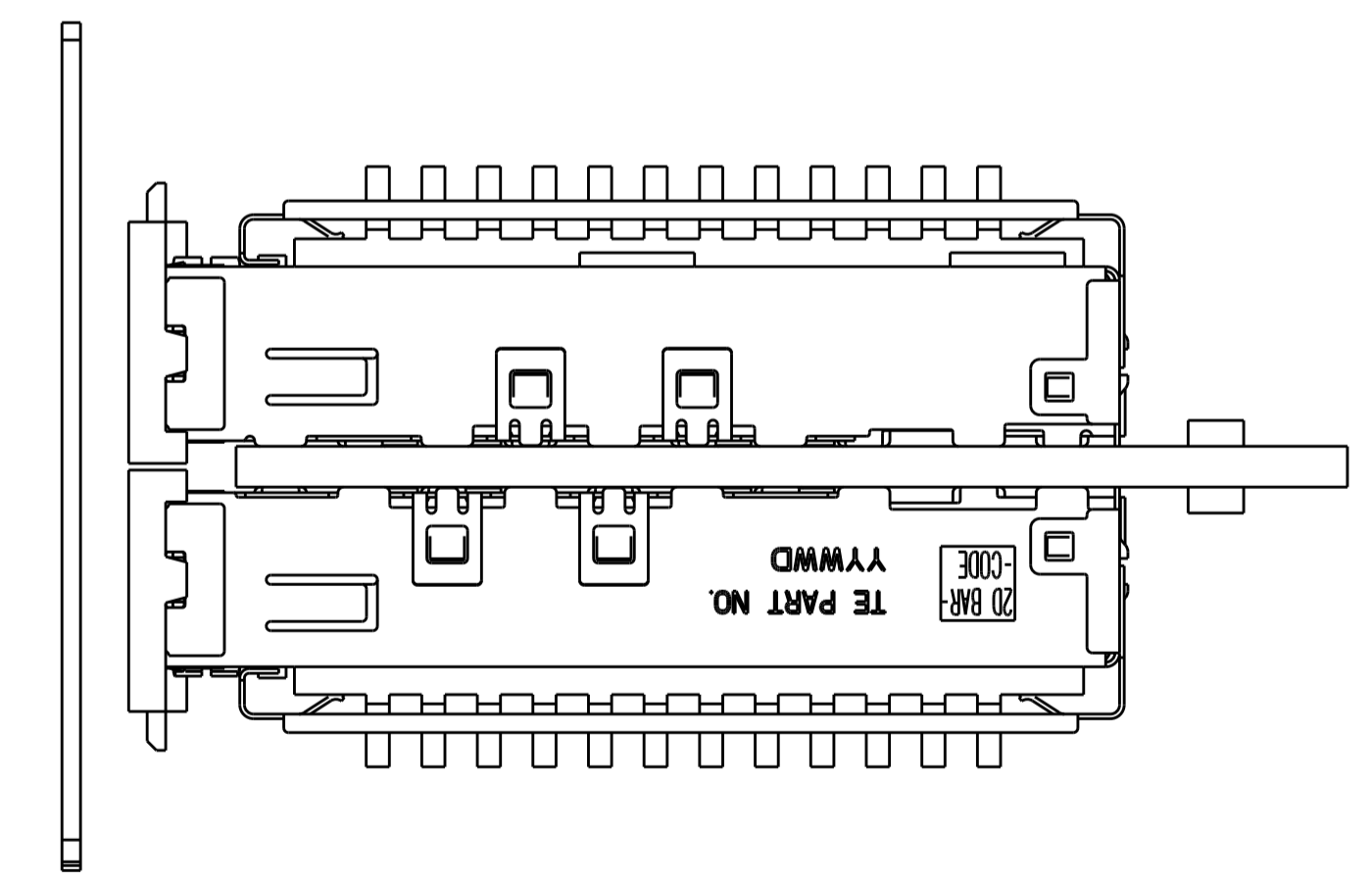
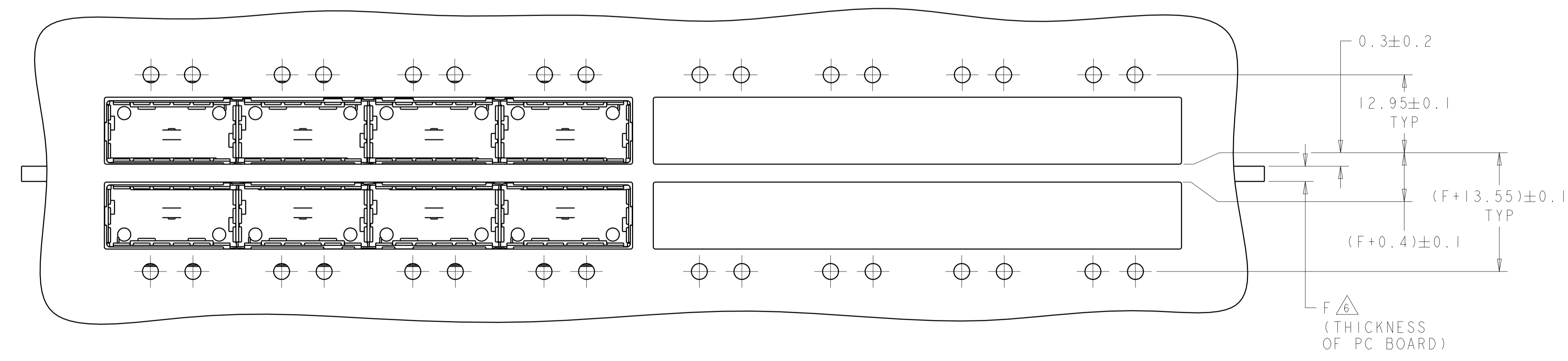

BELLY TO BELLY CONFIGURATION
 SIMILAR TO ONE SIDED
 EXCEPT WHERE NOTED
 SCALE 5:2

THIS DRAWING IS A CONTROLLED DOCUMENT.		OWN: 01JUL2013	TE Connectivity
DIMENSIONS: mm		CHK: JASON 01JUL2013	
TOLERANCES UNLESS OTHERWISE SPECIFIED:		APPD: AC 01JUL2013	NAME: 1X4 CAGE ASSEMBLY, BEHIND BEZEL, W/ LIGHT PIPES AND HEAT SINKS, QSFP
0 PLC ±	1 PLC ±0.1	PRODUCT SPEC	SIZE: A1
2 PLC ±0.1	3 PLC ±	108-2286	CAGE CODE: -
4 PLC ±	ANGLES ±	APPLICATION SPEC	DRAWING NO: C=2170567
MATERIAL: -	FINISH: -	114-13218	RESTRICTED TO: -
Customer Drawing		WEIGHT: -	SCALE: 4:1
			SHEET 3 OF 5
			REV: B1

LOC	DIST	REV	DATE	BY	APPD
GP	00				

REVISIONS			
NO.	DESCRIPTION	DATE	BY
1	SEE SHEET 1		

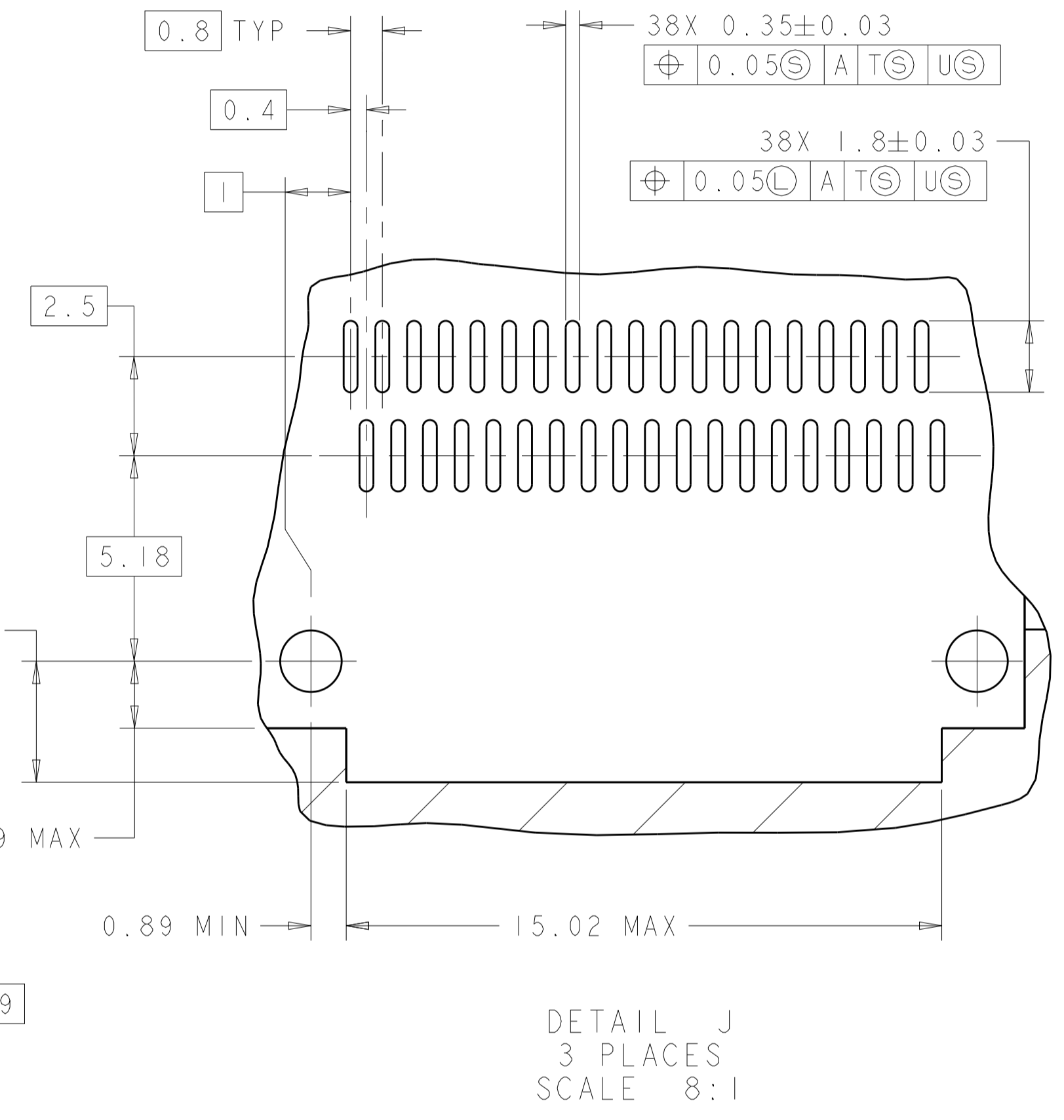
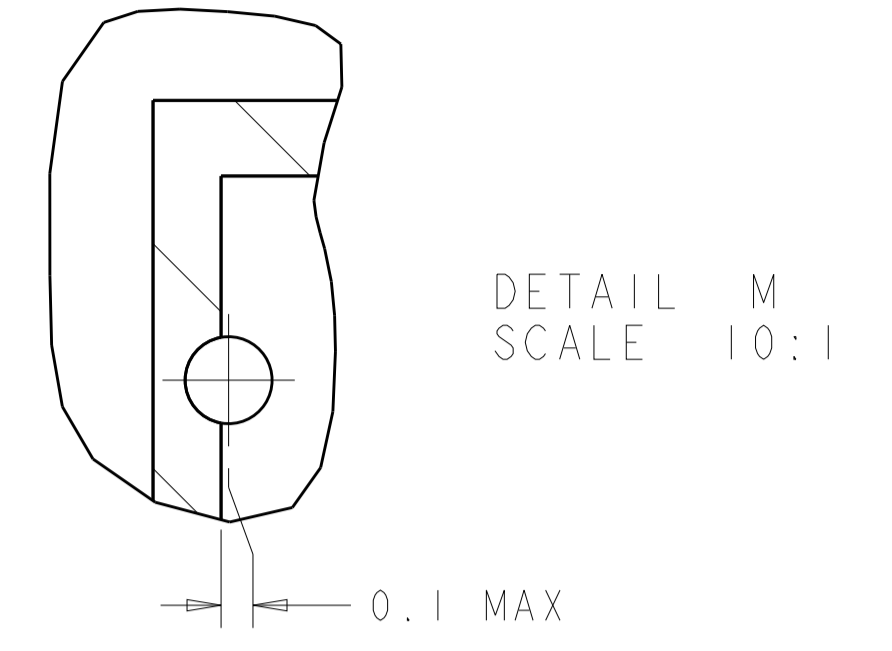
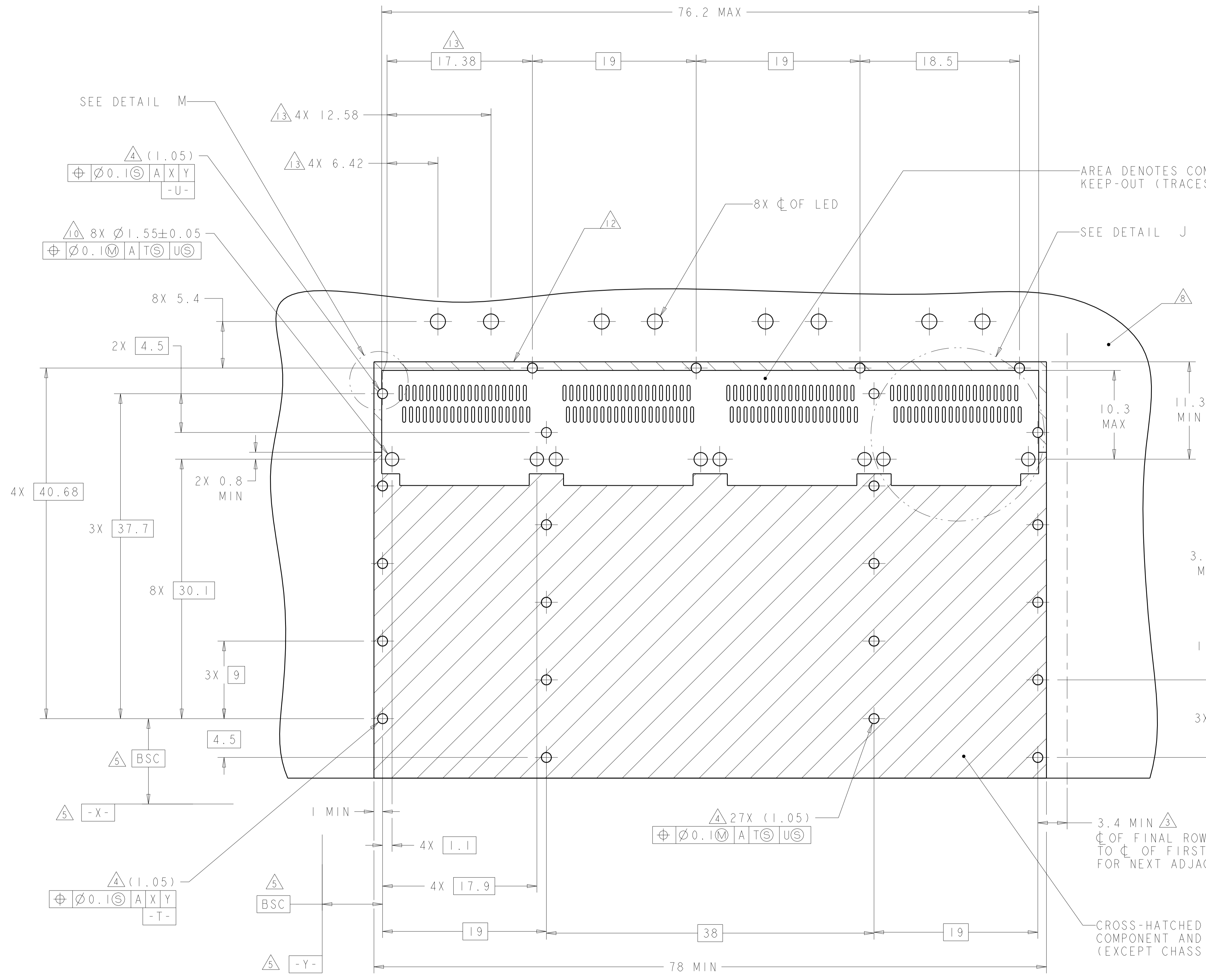

RECOMMENDED PC BOARD LAYOUT
SINGLE SIDE MOUNT CONFIGURATION
SCALE 4:1

AREA DENOTES COMPONENT
KEEP-OUT (TRACES PERMITTED)

SEE DETAIL J

3.4 MIN Δ
CL OF FINAL ROW OF HOLES
TO CL OF FIRST ROW OF HOLES
FOR NEXT ADJACENT CAGE

CROSS-HATCHED AREA DENOTES
COMPONENT AND TRACE KEEP-OUT
(EXCEPT CHASSIS GROUND)

THIS DRAWING IS A CONTROLLED DOCUMENT.		DWN: 01JUL2013	 TE Connectivity
DIMENSIONS: mm		CHK: JSAON 01JUL2013	
TOLERANCES UNLESS OTHERWISE SPECIFIED:		APPD: AC 01JUL2013	NAME: 1X4 CAGE ASSEMBLY, BEHIND BEZEL, W/ LIGHT PIPES AND HEAT SINKS, QSFP PRODUCT SPEC: 108-2286 APPLICATION SPEC: 114-13218
0 PLC ±		WEIGHT: -	
1 PLC ±0.1		SCALE: 4:1	SHEET 4 OF 5 REV B1
2 PLC ±0.1		Customer Drawing	
3 PLC ±			
4 PLC ±			
ANGLES ±			
FINISH			

LOC	DIST	REVISIONS			
P	LTN	DESCRIPTION	DATE	DMN	APVD
-	-	SEE SHEET 1	-	-	-

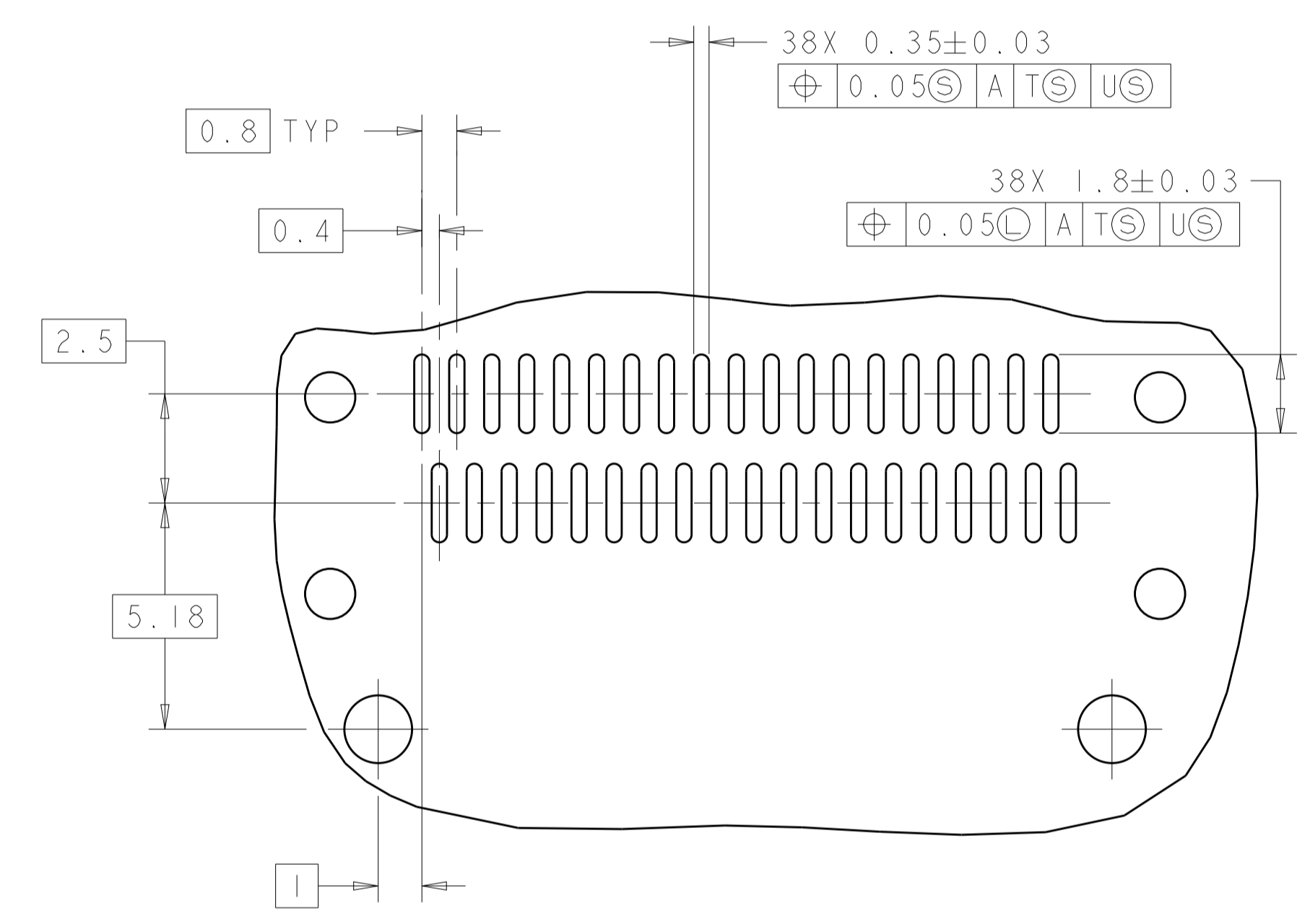
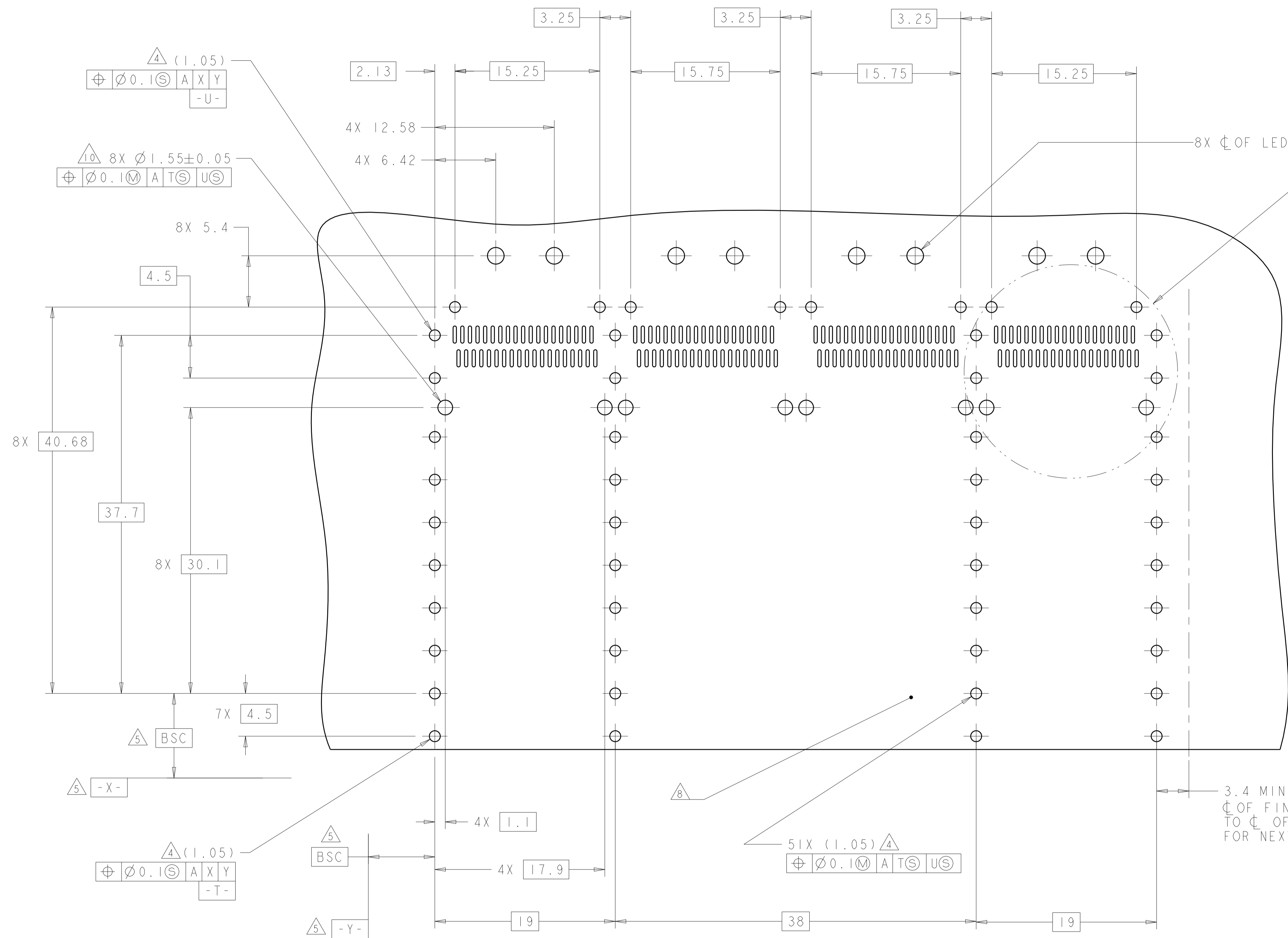

DETAIL K
SCALE 8:1

RECOMMENDED PC BOARD LAYOUT
BELLY TO BELLY CONFIGURATION
SEE SHEET 4 FOR COMPONENT AND TRACE KEEP-OUTS
SCALE 4:1

THIS DRAWING IS A CONTROLLED DOCUMENT.		DMN ZJ 01 JUL 2013	TE Connectivity
DIMENSIONS:		CHK JASON 01 JUL 2013	
mm	TOLERANCES UNLESS OTHERWISE SPECIFIED:	APVD AC 01 JUL 2013	NAME 1X4 CAGE ASSEMBLY, BEHIND BEZEL, W/ LIGHT PIPES AND HEAT SINKS, QSFP
	0 PLC \pm	PRODUCT SPEC 108-2286	SIZE A1
	1 PLC ± 0.1	APPLICATION SPEC	CAGE CODE C=2170567
	2 PLC ± 0.1	114-13218	RESTRICTED TO
	3 PLC \pm	WEIGHT	SCALE 4:1 SHEET 5 OF 5 REV B1
	4 PLC \pm	Customer Drawing	
	ANGLES \pm		
	FINISH		