



Low Voltage Intel® Pentium® III Processor with 512KB L2 Cache

Datasheet

Product Features

- Available at 800, 933, and 1000 MHz with a 133 MHz system bus frequency at 1.15 V (LV)
- 512-Kbyte Advanced Transfer Cache (on-die, full speed level two (L2) cache with Error Correcting Code (ECC))
- Dual Independent Bus (DIB) architecture: separate dedicated external system bus and dedicated internal high-speed cache bus
- Internet Streaming SIMD Extensions for enhanced video, sound and 3D performance
- Binary compatible with applications running on previous members of the Intel microprocessor line
- Dynamic execution micro architecture
- Power Management capabilities
 - System Management mode
 - Multiple low-power states
- Optimized for 32-bit applications running on advanced 32-bit operating systems
- Micro-FCBGA packaging technology
 - Supports small form factor designs
 - Exposed die enables more efficient heat dissipation
- Integrated high performance 16 Kbyte instruction and 16 Kbyte data, nonblocking, level one cache
- Quad Quadword Wide (256-bit) cache data bus provides extremely high throughput on read/store operations
- 8-way cache associativity provides improved cache hit rate on reads/store operations
- Error-correcting code for system bus data
- Dual processor capable

The LV Intel® Pentium® III processor 512K is designed for high-performance computing applications. It is binary compatible with previous Intel Architecture processors. The processor provides great performance for applications that run on advanced operating systems such as Microsoft® Windows® NT, Microsoft Windows 2000, Microsoft Windows XP and Linux. This is achieved by integrating the best attributes of Intel processors—the dynamic execution, Dual Independent Bus architecture plus Intel® MMX™ technology, and Internet Streaming SIMD Extensions—to bring a new level of performance to system designs. The LV Intel Pentium III processor with 512 Kbytes of L2 cache extends the power of the Intel Pentium III processor with performance headroom for applied computing and communications applications, and for high density Web serving and other front-end operations. Systems based on the LV Intel Pentium III Processor 512K also include the latest features to simplify system management and lower the cost of ownership.



Information in this document is provided in connection with Intel® products. No license, express or implied, by estoppel or otherwise, to any intellectual property rights is granted by this document. Except as provided in Intel's Terms and Conditions of Sale for such products, Intel assumes no liability whatsoever, and Intel disclaims any express or implied warranty, relating to sale and/or use of Intel products including liability or warranties relating to fitness for a particular purpose, merchantability, or infringement of any patent, copyright or other intellectual property right. Intel products are not intended for use in medical, life saving, or life sustaining applications.

Intel may make changes to specifications and product descriptions at any time, without notice.

Designers must not rely on the absence or characteristics of any features or instructions marked "reserved" or "undefined." Intel reserves these for future definition and shall have no responsibility whatsoever for conflicts or incompatibilities arising from future changes to them.

The Low Voltage Intel® Pentium® III processor 512K may contain design defects or errors known as errata that may cause the product to deviate from published specifications. Current characterized errata are available on request.

MPEG is an international standard for video compression/decompression promoted by ISO. Implementations of MPEG CODECs, or MPEG enabled platforms may require licenses from various entities, including Intel Corporation.

Contact your local Intel sales office or your distributor to obtain the latest specifications and before placing your product order.

Copies of documents that have an ordering number and are referenced in this document, or other Intel literature may be obtained by calling 1-800-548-4725 or by visiting Intel's website at <http://www.intel.com>.

Copyright © Intel Corporation, 2003

AlertVIEW, i960, AnyPoint, AppChoice, BoardWatch, BunnyPeople, CablePort, Celeron, Chips, Commerce Cart, CT Connect, CT Media, Dialogic, DM3, EtherExpress, ETOX, FlashFile, GatherRound, i386, i486, iCat, iCOMP, Insight960, InstantIP, Intel, Intel logo, Intel386, Intel486, Intel740, IntelDX2, IntelDX4, IntelSX2, Intel ChatPad, Intel Create&Share, Intel Dot.Station, Intel GigaBlade, Intel InBusiness, Intel Inside, Intel Inside logo, Intel NetBurst, Intel NetStructure, Intel Play, Intel Play logo, Intel Pocket Concert, Intel SingleDriver, Intel SpeedStep, Intel StrataFlash, Intel TeamStation, Intel WebOutfitter, Intel Xeon, Intel XScale, Itanium, JobAnalyst, LANDesk, LanRover, MCS, MMX, MMX logo, NetPort, NetportExpress, Optimizer logo, OverDrive, Paragon, PC Dads, PC Parents, Pentium, Pentium II Xeon, Pentium III Xeon, Performance at Your Command, ProShare, RemoteExpress, Screamline, Shiva, SmartDie, Solutions960, Sound Mark, StorageExpress, The Computer Inside, The Journey Inside, This Way In, TokenExpress, Trillium, Vivonic, and VTune are trademarks or registered trademarks of Intel Corporation or its subsidiaries in the United States and other countries.

*Other names and brands may be claimed as the property of others.

Contents

1.0	Introduction	7
1.1	Overview.....	7
1.2	Terminology.....	8
1.3	Related Documents.....	9
2.0	Processor Features	10
2.1	512-Kbyte On-Die Integrated L2 Cache.....	10
2.2	Data Prefetch Logic.....	10
2.3	Processor System Bus and V_{REF}	10
2.4	Differential Clocking.....	11
2.5	Clock Control and Low Power States.....	11
2.5.1	Normal State—State 1.....	12
2.5.2	AutoHALT Power Down State—State 2.....	12
2.5.3	Stop-Grant State—State 3.....	13
2.5.4	HALT/Grant Snoop State—State 4.....	13
2.5.5	Sleep State—State 5.....	13
2.5.6	Clock Control.....	14
2.6	Power and Ground Balls.....	14
2.7	Processor System Bus Clock and Processor Clocking.....	14
2.8	Processor System Bus Unused Balls.....	15
2.9	LV Intel Pentium III Processor 512K CPUID.....	15
3.0	Electrical Specifications	16
3.1	Processor System Bus Signal Groups.....	16
3.1.1	Asynchronous vs. Synchronous for System Bus Signals.....	17
3.1.2	System Bus Frequency Select Signals.....	17
3.2	Single-Ended Clocking BSEL[1:0] Implementation.....	17
3.3	Differential Host Bus Clocking Routing.....	18
3.3.1	Differential Clocking BSEL[1:0] Implementation.....	18
3.4	Signal State in Low-Power States.....	19
3.4.1	System Bus Signals.....	19
3.4.2	CMOS and Open-Drain Signals.....	19
3.4.3	Other Signals.....	19
3.5	Test Access Port (TAP) Connection.....	20
3.6	Power Supply Requirements.....	20
3.6.1	Decoupling Guidelines.....	20
3.6.2	Processor VCC_{CORE} Decoupling.....	20
3.6.3	Voltage Planes.....	21
3.7	Voltage Identification.....	21
3.8	System Bus Clock and Processor Clocking.....	24
3.9	Maximum Ratings.....	24
3.10	DC Specifications.....	25
3.11	AC Specifications.....	30
3.11.1	System Bus, Clock, APIC, TAP, CMOS, and Open-Drain AC Specifications.....	30

4.0	System Signal Simulations	40
4.1	System Bus Clock (BCLK) and PICCLK DC Specifications and AC Signal Quality Specifications	40
4.2	AGTL AC Signal Quality Specifications	42
4.3	Non-AGTL Signal Quality Specifications	43
4.3.1	PWRGOOD Signal Quality Specification	44
4.3.2	VTT_PWRGD Signal Quality Specification.....	44
5.0	Mechanical Specifications	46
5.1	Surface Mount Micro-FCBGA Package	46
5.2	Signal Listings.....	50
6.0	Thermal Specifications and Design Considerations	57
6.1	Thermal Specifications	57
6.1.1	THERMTRIP# Requirement	57
6.1.2	Thermal Diode	58
7.0	Processor Interface	59
7.1	Alphabetical Signals Reference.....	59
7.2	Signal Summaries.....	67

Figures

1	AGTL Bus Topology	11
2	Stop Clock State Machine	12
3	Differential/Single-Ended Clocking Example	15
4	Single Ended Clock BSEL Circuit (133 MHz)	18
5	Differential Clock BSEL Circuit	19
6	PLL Filter	21
7	V _{TT} Power Good and Bus Select Interconnect Diagram	23
8	Power Supply Current Slew Rate (dlcc _{CORE} /dt).....	26
9	V _{CC} _{CORE} Static and Transient Tolerance	27
10	BCLK (Single Ended)/PICCLK/TCK Generic Clock Timing Waveform	35
11	Differential BCLK/BCLK# Waveform (Common Mode)	35
12	BCLK/BCLK# Waveform (Differential Mode)	36
13	Valid Delay Timings.....	36
14	Setup and Hold Timings	37
15	Cold/Warm Reset and Configuration Timings	37
16	Power-On Sequence and Reset Timings	38
17	Test Timings (Boundary Scan)	39
18	Test Reset Timings.....	39
19	BCLK (Single-Ended)/PICCLK Generic Clock Waveform	41
20	Maximum Acceptable Overshoot/Undershoot Waveform.....	42
21	Noise Estimation.....	45
22	Micro-FCBGA Package – Top and Bottom Isometric Views	47
23	Micro-FCBGA Package – Top and Side Views	48
24	Micro-FCBGA Package - Bottom View	49
25	Ball Map - Top View	50

Tables

1	Related Documents	9
2	LV/ULV Intel® Pentium® III Processor 512K CPUID	15
3	System Bus Signal Groups.....	16
4	BSEL[1:0] Encoding.....	17
5	LV Intel Pentium III Processor 512K VID Values	22
6	LV Intel Pentium III Processor 512K Absolute Maximum Ratings	24
7	Power Specifications for LV Intel Pentium III Processor 512K	25
8	V _{CC} _{CORE} Static and Transient Tolerance	27
9	AGTL Signal Group Levels Specifications.....	28
10	Processor AGTL Bus Specifications.....	28
11	CLKREF, APIC, TAP, CMOS, and Open-Drain Signal Group DC Specifications	29
12	System Bus Clock AC Specifications (Differential).....	30
13	System Bus Clock AC Specifications (133 MHz, Single-Ended).....	31
14	Valid LV Intel Pentium III Processor 512K Frequencies	32
15	AGTL Signal Groups AC Specifications	32
16	CMOS and Open-Drain Signal Groups AC Specifications	32
17	Reset Configuration AC Specifications and Power On Timings	33
18	APIC Bus Signal AC Specifications.....	33
19	TAP Signal AC Specifications.....	34
20	BCLK (Differential) DC Specifications and AC Signal Quality Specifications.....	40
21	BCLK (Single-Ended) DC Specifications and AC Signal Quality Specifications.....	40
22	PICCLK DC Specifications and AC Signal Quality Specifications	41
23	133 MHz AGTL Signal Group Overshoot/Undershoot Tolerance at the Processor Core.....	43
24	Non-AGTL Signal Group Overshoot/Undershoot Tolerance at the Processor Core	43
25	Micro-FCBGA Package Mechanical Specifications	46
26	Signal List by Ball Number.....	51
27	Signal Listing by Signal Name	54
28	Voltage and No-Connect Ball Locations.....	56
29	LV Intel Pentium III Processor 512K Thermal Design Power	57
30	THERMTRIP# Time Requirement	57
31	Thermal Diode Interface	58
32	Thermal Diode Parameters.....	58
33	Signal Description.....	59
34	Input Signals	67
35	Output Signals	68
36	Input/Output Signals (Single Driver)	68
37	Input/Output Signals (Multiple Driver).....	68

Revision History

Date	Revision	Description
March 2002	-001	First release of this document.
September 2002	-002	Added 933MHz data and 06B4 stepping
September 2002	-003	Added Chapter 6 and 7
January 2003	-004	Added 1000MHz data
January 2003	-005	Updated Table 14, Power on Configuration Bits

1.0 Introduction

Using Intel's advanced 0.13-micron process technology with copper interconnect, the Low Voltage (LV) Intel® Pentium® III processor 512K offers high-performance and low-power consumption. Key performance features include Internet Streaming SIMD instructions, an Advanced Transfer Cache architecture, and a processor system bus speed of up to 133 MHz. These features are offered in a Micro-FCBGA package for surface mount boards. All of these technologies make outstanding performance possible for applied computing applications.

The 512 Kbyte integrated (on-die) level 2 (L2) cache, which is based on the Advanced Transfer Cache architecture, runs at the processor core speed and is designed to help improve performance. It complements the system bus by providing critical data faster and reducing total system power consumption. The processor's 64-bit wide Assisted Gunning Transceiver Logic (AGTL) system bus provides a glue-less interface for a memory controller hub.

This document provides the electrical, mechanical, and thermal specifications for the LV Intel Pentium III processor 512K in the Micro-FCBGA package at 800, 933, and 1000 MHz (1.15 V, LV). with a 133 MHz system bus.

For information not provided in this document, refer to the documents listed in [Table 1](#).

1.1 Overview

- Performance features
 - Supports the Intel Architecture with Dynamic Execution
 - Supports the Intel Architecture MMX™ technology
 - Supports Streaming SIMD Extensions for enhanced video, sound, and 3D performance
 - Integrated Intel Floating Point Unit compatible with the IEEE 754 standard
 - Data Prefetch Logic
- On-die primary (L1) instruction and data caches
 - 4-way set associative, 32-byte line size, 1 line per sector
 - 16-Kbyte instruction cache and 16-Kbyte write-back data cache
 - Cacheable range controlled by processor programmable registers
- On-die second level (L2) cache
 - 8-way set associative, 32-byte line size, 1 line per sector
 - Operates at full core speed
 - 512-Kbyte ECC protected cache data array
- AGTL system bus interface
 - 64-bit data bus, 133-MHz operation
 - Dual processor support
 - Integrated termination
- Thermal diode for measuring processor temperature

1.2 Terminology

Term	Definition
#	A “#” symbol following a signal name indicates that the signal is active low. This means that when the signal is asserted (based on the name of the signal) it is in an electrical low state. Otherwise, signals are driven in an electrical high state when they are asserted. In state machine diagrams, a signal name in a condition indicates the condition of that signal being asserted
!	Indicates the condition of that signal not being asserted. For example, the condition “!STPCLK# and HS” is equivalent to “the active low signal STPCLK# is unasserted (i.e., it is at 1.5 V) <i>and</i> the HS condition is true.”
L	Electrical low signal levels
H	Electrical high signal levels
0	Logical low. For example, BD[3:0] = “1010” = “HLHL” refers to a hexadecimal “A,” and D[3:0]# = “1010” = “LHLH” also refers to a hexadecimal “A.”
1	Logical high. For example, BD[3:0] = “1010” = “HLHL” refers to a hexadecimal “A,” and D[3:0]# = “1010” = “LHLH” also refers to a hexadecimal “A.”
TBD	Specifications that are yet to be determined and will be updated in future revisions of the document.
X	Don’t care condition
LV	DP Pentium III processor 512K at a core voltage of 1.15 V.
DP	Dual processor
UP	Single processor (uniprocessor)

1.3 Related Documents

Table 1. Related Documents

Document	Order Number
<i>P6 Family of Processors Hardware Developer's Manual</i>	244001
<i>IA-32 Intel® Architecture Software Developer's Manual</i> <ul style="list-style-type: none"> • <i>Volume I: Basic Architecture</i> • <i>Volume II: Instruction Set Reference</i> • <i>Volume III: System Programming Guide</i> 	245470 245471 245472
<i>VRM 8.5 DC-DC Converter Design Guidelines</i>	249659
<i>Low Voltage Intel® Pentium® III Processor 512K Dual Processor Platform Design Guide</i>	273674
<i>Low Voltage Intel® Pentium® III Processor 512K (DP) Thermal Design Guide</i>	273675
<i>Low Voltage Intel® Pentium® III Processor 512K/815E Chipset Platform Design Guide</i>	273676
<i>Intel® Pentium® III Processor Specification Update</i>	244453
<i>Intel Processor Identification and the CPUID Instruction</i>	241618

2.0 Processor Features

2.1 512-Kbyte On-Die Integrated L2 Cache

The LV Intel Pentium III processor 512K has a 512-Kbyte on-die integrated level 2 (L2) cache. The L2 cache runs at the processor core speed and the increased cache size provides superior processing power.

2.2 Data Prefetch Logic

The LV Intel Pentium III processor 512K features Data Prefetch Logic that speculatively fetches data to the L2 cache before an L1 cache request occurs. This reduces transactions between the cache and system memory, and reduces or eliminates bus cycle penalties, which improves performance. The processor also includes extensions to memory order and reorder buffers that boost performance.

2.3 Processor System Bus and V_{REF}

The LV Intel Pentium III processor 512K uses the original low voltage signaling of the Gunning Transceiver Logic (GTL) technology for the system bus. The GTL system bus operates at 1.25 V signal levels while GTL+ operates at 1.5 V signal levels. The GTL+ signal technology is used by the Intel® Pentium® Pro, Intel Pentium II and Intel Pentium III processors.

Current P6 family processors differ from the Intel Pentium Pro processor in their output buffer implementation. The buffers that drive the system bus signals on the LV Intel Pentium III processor 512K are actively driven to V_{TT} for one clock cycle after the low to high transition to improve rise times. These signals are open-drain and require termination to a supply. Because this specification is different from the standard GTL specification, it is referred to as AGTL, or Assisted GTL in this and other documentation related to the LV Intel Pentium III processor 512K.

AGTL logic and AGTL+ logic are not compatible with each other due to differences with the signal switching levels. The LV Intel Pentium III processor 512K cannot be installed into platforms where the chipset only supports the AGTL+ signal levels. For more information on AGTL or AGTL+ routing, please refer to the appropriate platform design guide.

AGTL inputs use differential receivers that require a reference voltage (V_{REF}). V_{REF} is used by the differential receivers to determine if the input signal is a logical 0 or a logical 1. The V_{REF} signal is typically implemented as a voltage divider on the platform. Noise decoupling is critical for the V_{REF} signal. Refer to the platform design guide for the recommended decoupling requirements.

Another important issue for the AGTL system bus is termination. System bus termination is used to pull each signal to a high voltage level and to control reflections on the transmission line. The processor contains on-die termination resistors that provide termination for one end of the system bus. The other end of the system bus should also be terminated by resistors placed on the platform or on-die termination within the agent. It is recommended that the system bus is implemented using Dual-End Termination (DET) to meet the timings and signal integrity specified by the LV Intel Pentium III processor 512K. [Figure 1](#) is a schematic representation of the AGTL bus topology for the LV Intel Pentium III processor 512K; in this figure the chipset does not have on-die termination.

Note: The RESET# signal requires a discrete external termination resistor on the system board.

The AGTL bus depends on incident wave switching. Therefore, timing calculations for AGTL signals are based on flight time as opposed to capacitive deratings. Analog signal simulations of the system bus, including trace lengths, are highly recommended, especially when the recommended layout guidelines are not followed.

Figure 1. AGTL Bus Topology

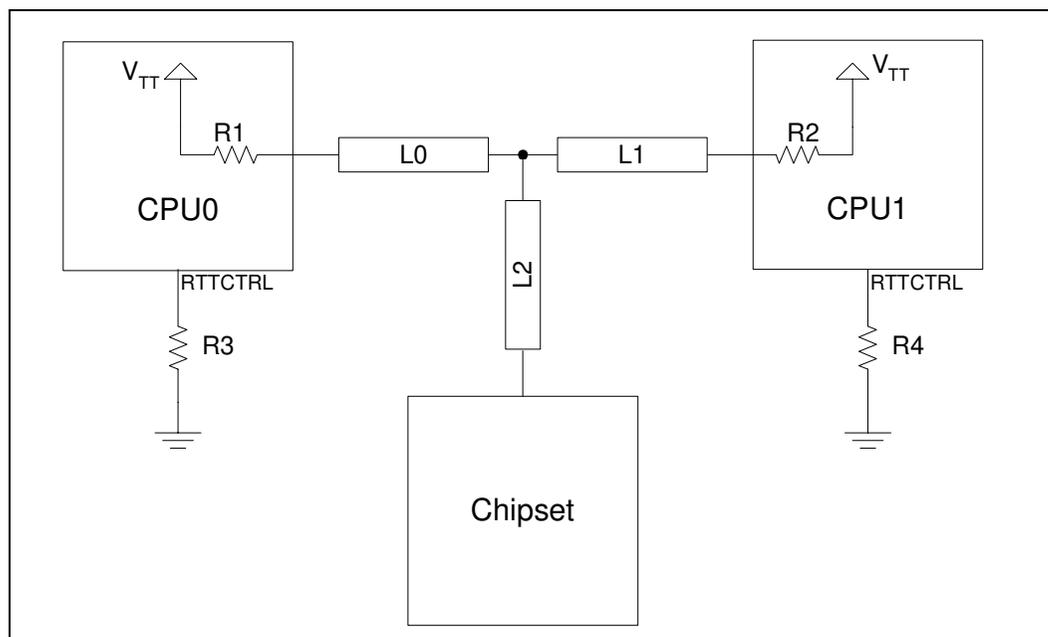

Note: R3 and R4 determine the nominal values of R1 and R2, respectively. Please refer to the *LV Intel® Pentium® III Processor 512K Dual Processor Platform Design Guide* for further dual processor system bus layout and topology information.

2.4 Differential Clocking

The LV Intel Pentium III processor 512K supports differential clocking. Differential clocking requires the use of two complementary clocks: BCLK and BCLK#. Benefits of differential clocking include easier scaling to lower voltages, reduced EMI, and less jitter. The LV Intel Pentium III processor 512K also supports single-ended clocking.

Note: All references to BCLK in this document also apply to BCLK#.

2.5 Clock Control and Low Power States

The processor allows the use of AutoHALT, Stop-Grant, and Sleep states to reduce power consumption by stopping the clock to internal sections of the processor, depending on each particular state. See [Figure 2](#) for a visual representation of the processor low power states.

Figure 2. Stop Clock State Machine

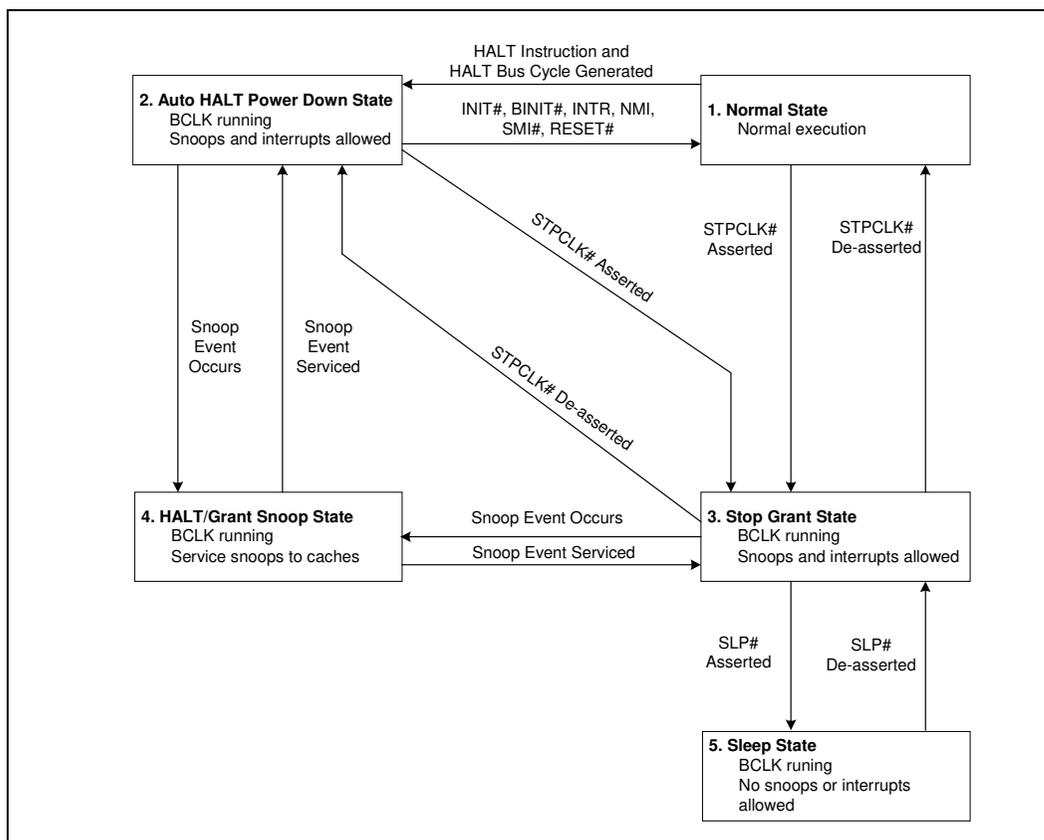

For the processor to fully realize the low current consumption of the Stop-Grant and Sleep states, a Model Specific Register (MSR) bit must be set. For the MSR at 02AH (Hex), bit 26 must be set to a '1' (this is the power on default setting) for the processor to stop all internal clocks during these modes. For more information, see the *Intel Architecture Software Developer's Manual, Volume 3: System Programming Guide*.

2.5.1 Normal State—State 1

This is the normal operating state for the processor.

2.5.2 AutoHALT Power Down State—State 2

AutoHALT is a low power state that is entered when the processor executes the HALT instruction. The processor transitions to the Normal state upon the occurrence of SMI#, INIT#, or LINT[1:0] (NMI, INTR). RESET# causes the processor to immediately initialize itself.

The return from a System Management Interrupt (SMI) handler can be to either Normal Mode or the AutoHALT Power Down state. See the *Intel Architecture Software Developer's Manual, Volume III: System Programmer's Guide* for more information.

FLUSH# is serviced during the AutoHALT state. Once the FLUSH# is complete the processor returns to the AutoHALT state.

The system can generate a STPCLK# while the processor is in the AutoHALT Power Down state. When the system deasserts the STPCLK# interrupt, the processor returns execution to the HALT state.

2.5.3 Stop-Grant State—State 3

The Stop-Grant state on the processor is entered when the STPCLK# signal is asserted.

Since the AGTL signal balls receive power from the system bus, these balls should not be driven. (allowing the level to return to V_{TT}) to minimize the power drawn by the termination resistors in this state. In addition, all other input balls on the system bus should be driven to the inactive state.

BINIT# and FLUSH# are not serviced during the Stop-Grant state.

RESET# causes the processor to immediately initialize itself, but the processor stays in Stop-Grant state. A transition back to the Normal state occurs with the deassertion of the STPCLK# signal.

A transition to the HALT/Grant Snoop state occurs when the processor detects a snoop on the system bus (see [Section 2.5.4](#)). A transition to the Sleep state (see [Section 2.5.5](#)) occurs with the assertion of the SLP# signal.

While in Stop-Grant State, SMI#, INIT#, and LINT[1:0] are latched by the processor, and only serviced when the processor returns to the Normal state. Only one occurrence of each event is recognized and serviced upon return to the Normal state.

2.5.4 HALT/Grant Snoop State—State 4

The processor responds to snoop transactions on the system bus while in Stop-Grant state or in AutoHALT Power Down state. During a snoop transaction, the processor enters the HALT/Grant Snoop state. The processor stays in this state until the snoop on the system bus has been serviced (whether by the processor or another agent on the system bus). After the snoop is serviced, the processor returns to the Stop-Grant state or AutoHALT Power Down state, as appropriate.

2.5.5 Sleep State—State 5

The Sleep state is a very low power state in which the processor maintains its context, maintains the phase-locked loop (PLL), and has stopped all internal clocks. The Sleep state can only be entered from the Stop-Grant state. Once in the Stop-Grant state, the SLP# ball can be asserted, causing the processor to enter the Sleep state. The SLP# ball is not recognized in the Normal or AutoHALT states.

Snoop events that occur while in Sleep State or during a transition into or out of Sleep state will cause unpredictable behavior.

In the Sleep state, the processor is incapable of responding to snoop transactions or latching interrupt signals. No transitions or assertions of signals (with the exception of SLP# or RESET#) are allowed on the system bus while the processor is in Sleep state. Any transition on an input signal before the processor has returned to Stop-Grant state will result in unpredictable behavior.

If RESET# is driven active while the processor is in the Sleep state, and held active as specified in the RESET# ball specification, then the processor will reset itself, ignoring the transition through Stop-Grant State. If RESET# is driven active while the processor is in the Sleep State, the SLP# and STPCLK# signals should be deasserted immediately after RESET# is asserted to ensure the processor correctly executes the reset sequence.

2.5.6 Clock Control

BCLK provides the clock signal for the processor and on-die L2 cache. During AutoHALT Power Down and Stop-Grant states, the processor processes a system bus snoop. The processor does not stop the clock to the L2 cache during AutoHALT Power Down or Stop-Grant states. Entrance into the Halt/Grant Snoop state allows the L2 cache to be snooped, similar to the Normal state.

When the processor is in Sleep state, it does not respond to interrupts or snoop transactions. During the Sleep state, the internal clock to the L2 cache is not stopped.

PICCLK should not be removed during the AutoHALT Power Down or Stop-Grant states. PICCLK can be removed during the Sleep state.

2.6 Power and Ground Balls

The operating voltage for the LV Intel Pentium III processor 512K is the same for the core and the L2 cache. VCC_{CORE} is defined as the power balls that supply voltage to the processor's core and cache. The Voltage Regulator Module (VRM) and the Voltage Regulator are controlled by the five voltage identification (VID) signals driven by the processor. The VID signals specify the voltage required by the processor core. Refer to [Section 3.7](#) for further details on the VID voltage settings.

The LV Intel Pentium III processor 512K has 81 VCC_{CORE}, 8 V_{REF}, 38 V_{TT}, and 146 V_{SS} inputs. The V_{REF} inputs are used as the AGTL reference voltage for the processor. The V_{TT} inputs (1.25 V) are used to provide an AGTL termination voltage to the processor. VCC_{CMOS1.5} and VCC_{CMOS1.8} and VCC_{CMOS2.0} are not voltage input balls to the processor. They are voltage sources for the pullup resistors that are connected to CMOS (non-AGTL) input/output signals that are driven to/from the processor. The V_{SS} inputs are ground balls for the processor core and L2 cache.

On the platform, all VCC_{CORE} balls must be connected to a voltage island (an island is a portion of a power plane that has been divided, or it is an entire voltage plane) to minimize any voltage drop that may occur due to trace impedance. It is also highly recommended that the platform provide either a voltage island or a wide trace for the V_{TT} balls. Similarly, all V_{SS} balls must be connected to a system ground plane. Refer to the *LV Intel® Pentium® III Processor 512K Dual Processor Platform Design Guide* for more information.

2.7 Processor System Bus Clock and Processor Clocking

The LV Intel Pentium III processor 512K has an auto-detect mechanism that allows the processor to use either single-ended or differential signaling for the system bus and processor clocking. The processor checks to see if the signal on ball AD1 is toggling. If this signal is toggling then the processor operates in differential mode. Refer to [Figure 3](#) for an example on differential clocking. Resistor values and clock topology are listed in the appropriate platform design guide for a differential implementation.

Note: In this document, references to BCLK also apply to its complement signal (BCLK#) in differential implementations and when noted otherwise.

Figure 3. Differential/Single-Ended Clocking Example

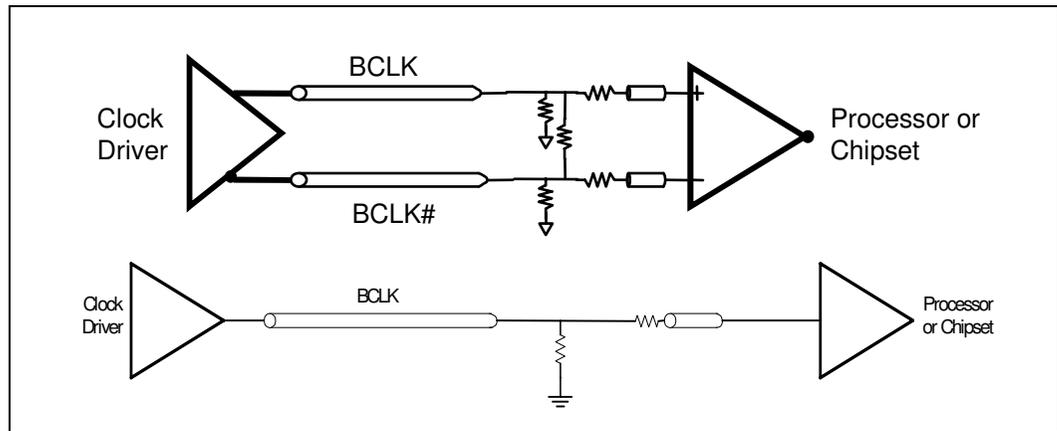

2.8 Processor System Bus Unused Balls

All RESERVED balls must remain unconnected unless specifically noted. Connection of these balls to $V_{CC_{CORE}}$, V_{REF} , V_{SS} , V_{TT} or to any other signal (including each other) can result in component malfunction or incompatibility with future processors. See Section 5.2 for a ball listing of the processor and the location of each ball that should be left unconnected (NC).

For reliable operation, always connect unused inputs or bidirectional signals to their deasserted signal level. The pull-up or pull-down resistor values are system dependent and should be chosen so that the logic high (V_{IH}) and logic low (V_{IL}) requirements are met. See Table 11 for level specifications of non-AGTL signals.

For unused AGTL inputs, the on-die termination will be sufficient. No external R_{TT} is necessary on the motherboard.

For unused CMOS inputs, active low signals should be connected to $V_{CC_{CMOS1.5}}$ through a pull-up resistor and should meet V_{IH} requirements. Unused active high CMOS inputs should be connected to ground (V_{SS}) through a pull-down resistor and should meet V_{IL} requirements. Unused CMOS outputs can be left unconnected. A resistor must be used when tying bidirectional signals to power or ground. When tying a signal to power or ground, a resistor will also allow for system testability.

2.9 LV Intel Pentium III Processor 512K CPUID

After a power-on RESET or when the CPUID version information is loaded, the EAX and EBX registers contain the values shown in Table 2.

Table 2. LV/ULV Intel® Pentium® III Processor 512K CPUID

EAX[31:0]					EBX[7:0]
Reserved [31:14]	Type [13:12]	Family [11:8]	Model [7:4]	Stepping [3:0]	Brand ID
X	0	6	B	X	2
X	0	6	B	X	4

3.0 Electrical Specifications

3.1 Processor System Bus Signal Groups

To simplify the following discussion, the processor system bus signals have been combined into groups by buffer type. All P6 family processor system bus outputs are open drain and require termination resistors. However, the LV Intel Pentium III processor 512K includes on-die termination for AGTL signals. This makes it unnecessary to place termination resistors on the platform, except in the case of the RESET# signal, which still requires external termination.

AGTL input signals have differential input buffers that use V_{REF} as a reference signal. AGTL output signals require termination to 1.25 V. In this document, the term “AGTL Input” refers to the AGTL input group and to the AGTL I/O group when this group is receiving signals. Similarly, “AGTL Output” refers to the AGTL output group and to the AGTL I/O group when this group is driving signals.

The PWRGOOD signal input is a 1.8 V signal level and must be pulled up to $V_{CC_{CMOS1.8}}$. The VTT_PWRGD is *not* 1.8 V tolerant and must be connected to V_{TT} (1.25 V). Other CMOS inputs (A20M#, IGNNE#, INIT#, LINT0/INTR, LINT1/NMI, PREQ#, SMI#, SLP#, and STPCLK#) are only 1.5 V tolerant and must be pulled up to $V_{CC_{CMOS1.5}}$. The CMOS, APIC, and TAP outputs are open drain and must be pulled to the appropriate level to meet the input specifications of the interfacing device.

The groups and the signals contained within each group are shown in [Table 3](#). Refer to “[Processor Interface](#)” on [page 59](#) for a description of these signals.

Table 3. System Bus Signal Groups (Sheet 1 of 2)

Group Name	Signals
AGTL Input	BPRI#, DEFER#, RESET#, RSP#, BR1#
AGTL Output	PRDY#
AGTL I/O	A[35:3]#, ADS#, AERR#, AP[1:0]#, BERR#, BINIT#, BNR#, BP[3:2]#, BPM[1:0]#, BR0#, D[63:0]#, DBSY#, DEP[7:0]#, DRDY#, HIT#, HITM#, LOCK#, REQ[4:0]#, RP#, RS[2:0]#, TRDY#
1.5 V CMOS Input	A20M#, FLUSH#, IGNNE#, INIT#, LINT0/INTR, LINT1/NMI, PREQ#, SLP#, SMI#, STPCLK#
1.8 V CMOS Input	PWRGOOD
1.5 V Open Drain Output	FERR#, IERR#, THERMTRIP#
3.3 V Open Drain Output	BSEL[1:0], VID[3:0, 25mV]
1.25 V input	VTT_PWRGD
Clock	BCLK, BCLK# (Differential Mode)
2.5 V Clock Input	BCLK (Single Ended Mode)

NOTES:

1. $V_{CC_{CORE}}$ is the power supply for the core logic.
2. PLL1 and PLL2 are power/ground for the PLL analog section. See “[Voltage Planes](#)” on [page 21](#) for details.
3. V_{TT} is the power supply for the system bus buffers.
4. V_{REF} is the voltage reference for the AGTL input buffers.
5. V_{SS} is system ground.

Table 3. System Bus Signal Groups (Sheet 2 of 2)

APIC Clock	PICCLK
APIC I/O	PICD[1:0]
Thermal Diode	THERMDN, THERMDP
TAP Input	TCK, TDI, TMS, TRST#
TAP Output	TDO
Power/Other	CLKREF, VCMOS_REF, SLEWCTRL, NCHCTRL, PLL1, PLL2, RTTCTRL, VCCCORE, VTT, VREF, VSS

NOTES:

1. VCCCORE is the power supply for the core logic.
2. PLL1 and PLL2 are power/ground for the PLL analog section. See “Voltage Planes” on page 21 for details.
3. VTT is the power supply for the system bus buffers.
4. VREF is the voltage reference for the AGTL input buffers.
5. VSS is system ground.

3.1.1 Asynchronous vs. Synchronous for System Bus Signals

All AGTL signals are synchronous to BCLK (BCLK/BCLK#). All of the CMOS, Clock, APIC, and TAP signals can be applied asynchronously to BCLK (BCLK/BCLK#). All APIC signals are synchronous to PICCLK. All TAP signals are synchronous to TCK.

3.1.2 System Bus Frequency Select Signals

The BSEL[1:0] (Select Processor System Bus Speed) signals are used to configure the processor for the system bus frequency. The VTT_PWRGD signal informs the processor to output the BSEL signals. During power up the BSEL signals are indeterminate for a small period of time. If the clock generator supports this dynamic BSEL selection, it should not sample the BSEL signals until the VTT_PWRGD signal is asserted. The assertion of the VTT_PWRGD signal indicates that the BSEL signals are stable and driven to a final state by the processor.

Table 4 shows the encoding scheme for BSEL[1:0]. The only supported system bus frequency for the LV Pentium III processor 512K is 133 MHz. If another frequency is used, the processor is not guaranteed to function properly.

Table 4. BSEL[1:0] Encoding

BSEL[1:0]	System Bus Frequency
11	133 MHz

3.2 Single-Ended Clocking BSEL[1:0] Implementation

In an LV Intel Pentium III processor 512K platform that is using single-ended clocking or a clock source that does not support the VTT_PWRGD protocol, the normal BSEL frequency selection process will not work. Since the clock generator is not compatible with dynamic BSEL assertions, all BSEL[1:0] signals should not be connected together. Instead, the BSEL pins on the clock generator should be pulled-up to 3.3 V through a 1 KΩ, 5% resistor. This strapping forces the clock generator into 133 MHz clocking mode. It only supports 133 MHz capable processors.

Figure 4. Single Ended Clock BSEL Circuit (133 MHz)

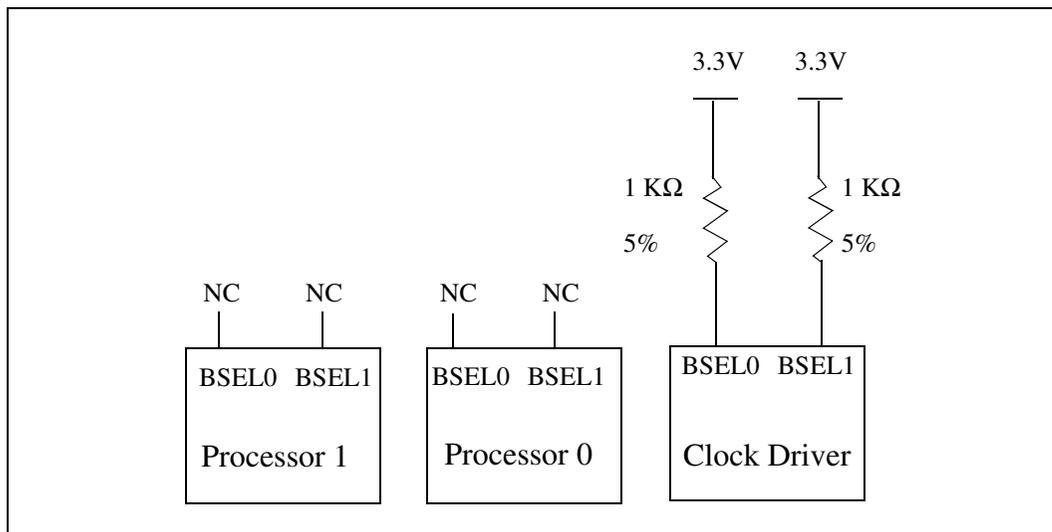

3.3 Differential Host Bus Clocking Routing

LV Intel Pentium III processor 512K dual-processor platforms support differential host bus clock drivers. When operating in differential clocking mode, the BCLK and BCLK#/CLKREF form a differential pair of clock inputs. The differential pair of traces should be routed with special care and using standard differential signaling techniques. Refer to the *LV Intel® Pentium® III Processor 512K Dual Processor Platform Design Guide* for more information.

The following sections contain the recommended topology and routing for differential clocking in the LV Intel Pentium III processor 512K dual-processor platforms.

3.3.1 Differential Clocking BSEL[1:0] Implementation

The System Bus Frequency Select Signals (BSEL[1:0]) are used to select the system bus frequency for the host bus agents. Frequency selection is determined by the processor(s) and driven out to the host bus clock generator. All system bus agents must operate at the same 133 MHz frequency. The BSEL balls for the processor are open drain signals and rely on a 3.3 V pull-up resistor to set the signal to a logic high level. [Figure 5](#) shows the recommended implementation for a differentially clocked system.

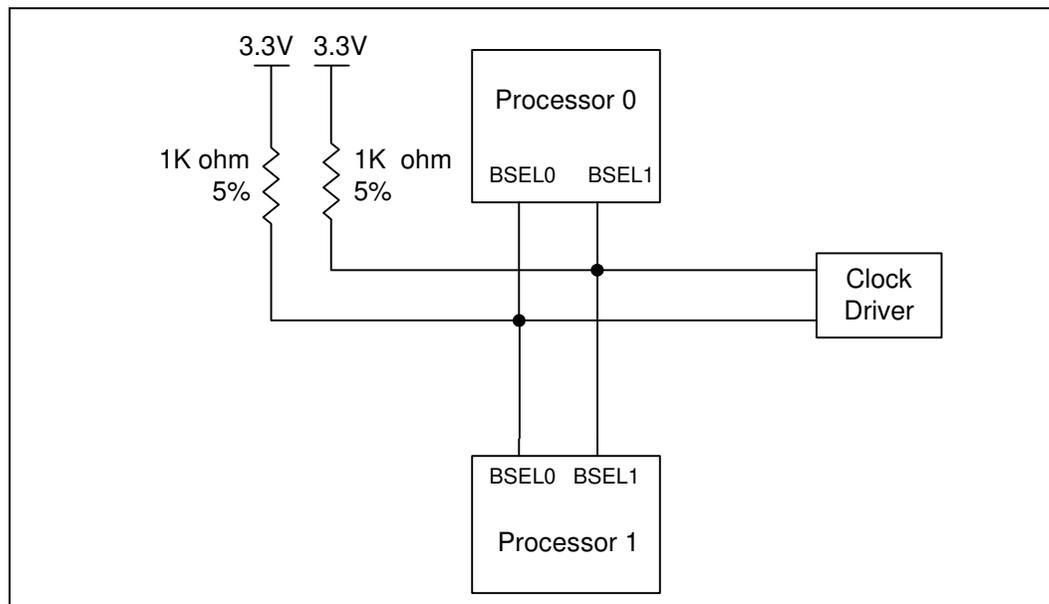
Figure 5. Differential Clock BSEL Circuit

3.4 Signal State in Low-Power States

3.4.1 System Bus Signals

All of the system bus signals have AGTL input, output, or input/output drivers. The system bus signals are tri-stated and pulled up by the termination resistors unless they are servicing snoops.

3.4.2 CMOS and Open-Drain Signals

The CMOS input signals are allowed to be in either the logic high or low state when the processor is in a low-power state. In the Auto Halt state these signals are allowed to toggle. These input buffers have no internal pull-up or pull-down resistors and system logic can use CMOS or open-drain drivers to drive them.

The open-drain output signals have open drain drivers that require external pull-up resistors. One of the two output signals (IERR#) is a catastrophic error indicator and is tri-stated (and pulled-up) when the processor is functioning normally. The FERR# output can be either tri-stated or driven to V_{SS} when the processor is in a low-power state, depending on the condition of the floating-point unit.

3.4.3 Other Signals

The system bus clocks (BCLK, BCLK#) must be driven in all of the low-power states. The APIC clock (PICCLK) must be driven whenever BCLK and BCLK# are driven. Otherwise, it is permitted to turn off PICCLK by holding it at V_{SS} . BCLK and BCLK# must remain within the DC specifications in [Table 20](#) (for differential clocking) and [Table 21](#) (for single-ended clocking).

In the Auto Halt state, the APIC bus data signals (PICD[1:0]) may toggle due to APIC bus messages.

3.5 Test Access Port (TAP) Connection

The TAP interface is an implementation of the IEEE 1149.1 (“JTAG”) standard. Due to the voltage levels supported by the TAP interface, Intel recommends that the LV Intel Pentium III processor 512K and the other 1.5 V JTAG specification compliant devices be placed last in the JTAG chain, behind any system devices with 3.3 V or 5.0 V JTAG interfaces. A translation buffer should be used to reduce the TDO output voltage of the last 3.3/5.0 V device down to the 1.5 V range that the processor can tolerate. Multiple copies of TMS and TRST# must be provided, one for each voltage level.

A Debug Port and connector may be placed at the start and at the end of the JTAG chain that contains the processor, with TDI to the first component coming from the Debug Port, and TDO from the last component going to the Debug Port. There are no requirements for placing the processor in the JTAG chain, except for those that are dictated by the voltage requirements of the TAP signals.

3.6 Power Supply Requirements

3.6.1 Decoupling Guidelines

Due to the large number of transistors and high internal clock speeds, the processor is capable of generating large average current swings between low and full power states. These fluctuations can cause voltages on power planes to sag below their nominal values if bulk decoupling is not adequate. Care must be taken in the board design to ensure that the voltage provided to the processor remains within the specifications listed in [Table 7](#). Failure to do so can result in timing violations (in the event of a voltage sag) or a reduced lifetime of the component (in the event of a voltage overshoot).

3.6.2 Processor VCC_{CORE} Decoupling

The regulator for the VCC_{CORE} input must be capable of delivering the $dI_{CC_{CORE}}/dt$ (defined in [Table 7](#)) while maintaining the required tolerances (defined in [Table 9](#)). Failure to meet these specifications can result in timing violations (during VCC_{CORE} sag) or a reduced lifetime of the component (during VCC_{CORE} overshoot).

The processor requires both high frequency and bulk decoupling on the system motherboard for proper AGTL bus operation. The minimum recommendation for the processor decoupling requirement is listed below.

The LV Intel Pentium III processor 512K has eight 0.68- μ F surface mount decoupling capacitors. Six 0.68- μ F capacitors are on VCC_{CORE} and two 0.68- μ F capacitors are on V_{TT}. In addition to the package capacitors, sufficient board level capacitors are also necessary for power supply decoupling. These guidelines are as follows:

- High and Mid Frequency VCC_{CORE} decoupling – Place twenty-four 0.22- μ F 0603 capacitors directly under the package on the solder side of the motherboard, using at least two vias per capacitor node. Ten 10- μ F X7R 6.3 V 1206-size ceramic capacitors should be placed around the package periphery near the balls. Trace lengths to the vias should be designed to minimize inductance. Avoid bending traces to minimize ESL.
- High and Mid Frequency V_{TT} decoupling – Place ten 1- μ F X7R 0603 ceramic capacitors close to the package. Via and trace guidelines are the same as above.

For additional decoupling requirements, please refer to the appropriate platform design guide for recommended capacitor component value/quantity and placement.

3.6.3 Voltage Planes

All $V_{CC_{CORE}}$ and V_{SS} balls must be connected to the appropriate voltage plane. All V_{TT} and V_{REF} balls must be connected to the appropriate traces on the system electronics. In addition to the main $V_{CC_{CORE}}$, V_{TT} , and V_{SS} power supply signals, PLL1 and PLL2 provide analog decoupling to the PLL section. PLL1 and PLL2 should be connected according to Figure 6. Do not connect PLL2 directly to V_{SS} .

Figure 6. PLL Filter

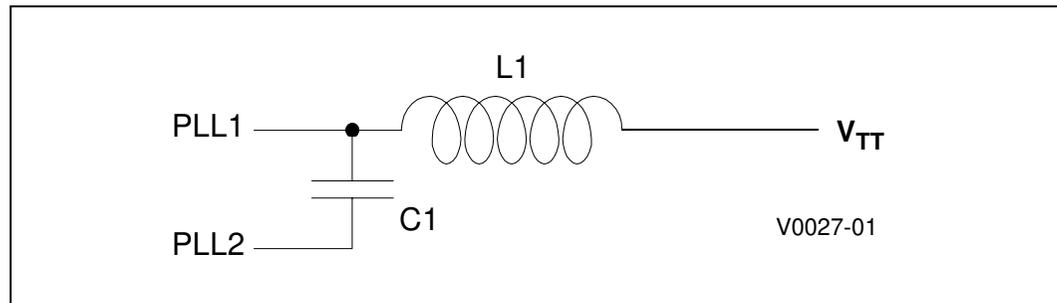

3.7 Voltage Identification

There are five voltage identification (VID) balls on the LV Intel Pentium III processor 512K. These balls can be used to support automatic selection of $V_{CC_{CORE}}$ voltages. The VID balls for the LV Intel Pentium III processor 512K are open drain signals versus opens or shorts. Refer to Table 11 for level specifications for the VID signals. These pull-up resistors may be either external logic on the motherboard or internal to the voltage regulator.

The VID signals rely on a 3.3 V pull-up resistor to set the signal to a logic high level. The VID balls are needed to fully support voltage specification variations on current and future processors. The voltage selection range for the processor is defined in Table 5. The VID25mV signal is a new signal that allows the voltage regulator or voltage regulator module (VRM) to output voltage levels in 25 mV increments. The voltage regulator or VRM must supply the voltage that is requested or disable itself.

In addition to the new signal VID25mV, the LV Intel Pentium III processor 512K has a second new signal labeled VTT_PWRGD. The VTT_PWRGD signal informs the platform that the VID and BSEL signals are stable and should be sampled. During power-up, the VID signals will be in an indeterminate state for a small period of time. The voltage regulator or the VRM should not latch the VID signals until the VTT_PWRGD signal is asserted by the VRM and is sampled active. The assertion of the VTT_PWRGD signal indicates that the VID signals are stable and are driven to the final state by the processor. Refer to Figure 16 for power-up timing sequence for the VTT_PWRGD and the VID signals.

Table 5. LV Intel Pentium III Processor 512K VID Values

VID25mV	VID3	VID2	VID1	VID0	VCC _{CORE}
0	0	1	0	0	1.05
1	0	1	0	0	1.075
0	0	0	1	1	1.10
1	0	0	1	1	1.125
0	0	0	1	0	1.15
1	0	0	1	0	1.175
0	0	0	0	1	1.20
1	0	0	0	1	1.225
0	0	0	0	0	1.25
1	0	0	0	0	1.275
0	1	1	1	1	1.30
1	1	1	1	1	1.325
0	1	1	1	0	1.35
1	1	1	1	0	1.375
0	1	1	0	1	1.40
1	1	1	0	1	1.425
0	1	1	0	0	1.45
1	1	1	0	0	1.475
0	1	0	1	1	1.50
1	1	0	1	1	1.525
0	1	0	1	0	1.55
1	1	0	1	0	1.575
0	1	0	0	1	1.60
1	1	0	0	1	1.625
0	1	0	0	0	1.65
1	1	0	0	0	1.675
0	0	1	1	1	1.70
1	0	1	1	1	1.725
0	0	1	1	0	1.75
1	0	1	1	0	1.775
0	0	1	0	1	1.80
1	0	1	0	1	1.825

NOTES:

1. 0 = Processor ball connected to V_{SS} and 1 = Open on processor; may be pulled up to TTL V_{IH} (3.3V max) on baseboard.

The VID balls should be pulled up to a 3.3-V level. This may be accomplished with pull-ups internal to the voltage regulator, which ensures valid VID pull-up voltage during power-up and power-down sequences. When external resistors are used for the VID[3:0, 25mV] signal, the power source must be guaranteed to be stable whenever the supply to the voltage regulator is stable. This will prevent the possibility of the processor supply going above the specified V_{CC_CORE} in the event of a failure in the supply for the VID lines. In the case of a DC-to-DC converter, this can be accomplished by using the input voltage to the converter for the VID line pull-ups. A resistor equal to 1 K Ω may be used to connect the VID signals to the voltage regulator input.

Important: Intel requires that designs utilize VRM 8.5 and not IMVP-II specifications to meet the LV Intel Pentium III processor 512K requirements.

To re-emphasize, VRM 8.5 introduces two new signals [VID25mV and VTT_PWRGD] that are used by the LV Intel Pentium III processor 512K and platform. Failing to connect these two new balls as documented in the design guidelines (provided in the *LV Intel® Pentium® III Processor 512K Dual Processor Platform Design Guide*) will prevent the LV Intel Pentium III processor 512K from operating at the specified voltage levels and core frequency. Figure 7 provides a high-level interconnection schematic. Please refer to the *VRM 8.5 DC-DC Converter Design Guideline* and the appropriate platform design guidelines for further detailed information on the voltage identification and bus select implementation.

Refer to Figure 16 for VID power-up sequence and timing requirements.

Figure 7. V_{TT} Power Good and Bus Select Interconnect Diagram

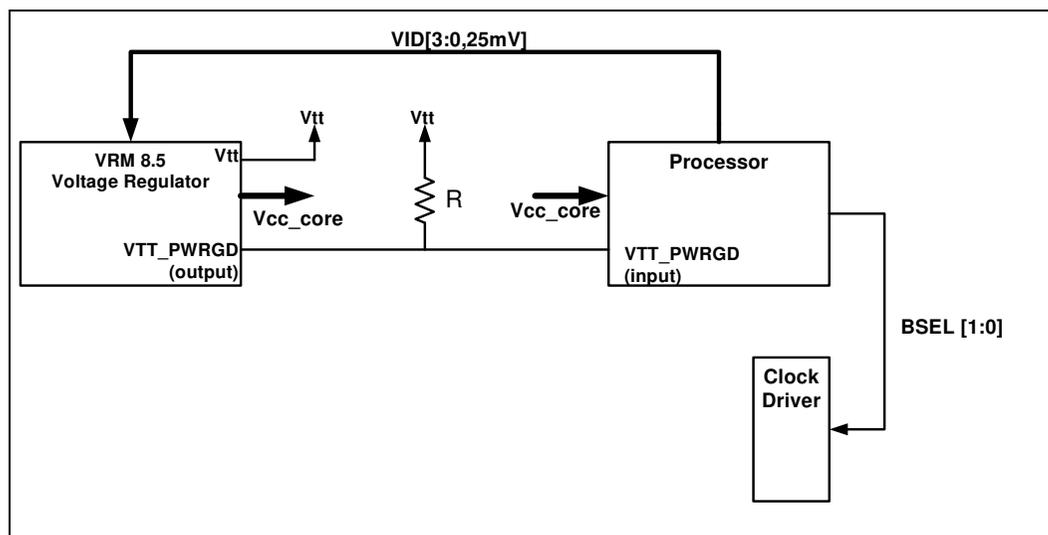

Note: Please refer to the *LV Intel® Pentium® III Processor 512K Dual Processor Platform Design Guide* for VTT_PWRGD implementation for an LV Intel Pentium III processor 512K platform.

Separate VRM 8.5 voltage regulators and processor core voltage planes are required for each processor in a dual-processor system.

3.8 System Bus Clock and Processor Clocking

The BCLK and BCLK# clock inputs directly control the operating speed of the system bus interface. All system bus timing parameters are specified with respect to the crossing point of the rising edge of the BCLK input and the falling edge of the BCLK# input. The LV Intel Pentium III processor 512K core frequency is a multiple of the BCLK frequency. The processor core frequency is configured during manufacturing. The configured bus ratio is visible to software in the power-on configuration register.

Multiplying the bus clock frequency is necessary to increase performance while allowing for easier distribution of signals within the system. Clock multiplication within the processor is provided by the internal Phase Lock Loop (PLL), which requires constant frequency BCLK, BCLK# inputs. During Reset, the PLL requires some amount of time to acquire the phase of BCLK and BCLK#. This time is called the PLL lock latency, which is specified in [Table 17 on page 33](#); see the AC timing parameter for T18.

3.9 Maximum Ratings

[Table 6](#) contains the LV Intel Pentium III processor 512K stress ratings. Functional operation at the absolute maximum and minimum is neither implied nor guaranteed. The processor should not receive a clock while subjected to these conditions. Functional operating conditions are provided in the AC and DC tables. Extended exposure to the maximum ratings may affect device reliability. Furthermore, although the processor contains protective circuitry to resist damage from static electric discharge, one should always take precautions to avoid high static voltages or electric fields.

Table 6. LV Intel Pentium III Processor 512K Absolute Maximum Ratings

Symbol	Parameter	Min	Max	Unit	Notes
$T_{Storage}$	Storage Temperature	-40	85	°C	1
$V_{CCORE(Abs)}$	Supply Voltage with respect to V_{SS}	-0.5	1.75	V	
V_{TT}	System Bus Buffer Voltage with respect to V_{SS}	-0.3	1.75	V	
$V_{IN\ AGTL}$	System Bus Buffer DC Input Voltage with respect to V_{SS}	-0.3	1.75	V	2, 3
V_{IN125}	1.25 V Buffer DC Input Voltage with respect to V_{SS}	-0.3	1.75	V	4
V_{IN15}	1.5 V Buffer DC Input Voltage with respect to V_{SS}	-0.3	2.0	V	5
V_{IN18}	1.8 V Buffer DC Input Voltage with respect to V_{SS}	-0.3	2.0	V	6
V_{IN20}	2.0 V Buffer DC Input Voltage with respect to V_{SS}	-0.3	2.4	V	7
V_{IN25}	2.5 V Buffer DC Input Voltage with respect to V_{SS}	-0.3	3.3	V	8
V_{INVID}	VID ball DC Input Voltage with respect to V_{SS}	—	3.465	V	9
I_{VID}	VID Current	-0.3	3.6	mA	9

NOTES:

1. The shipping container is only rated for 65° C.
2. Parameter applies to the AGTL signal groups only. Compliance with both $V_{IN\ AGTL}$ specifications is required.
3. The voltage on the AGTL signals must never be below -0.3 or above 1.75 V with respect to ground.
4. Parameter applies to CLKREF, TESTHI, VTT_PWRGD signals.
5. Parameter applies to CMOS, Open-drain, APIC, TESTLO and TAP bus signal groups only.
6. Parameter applies to PWRGOOD signal.
7. Parameter applies to PICCLK signal.
8. Parameter applies to BCLK signal in Single-Ended Clocking Mode.
9. Parameter applies to each VID ball individually.

3.10 DC Specifications

Tables 7 through 11 list the DC specifications for the LV Intel Pentium III processor 512K. Specifications are valid only while meeting specifications for the junction temperature, clock frequency, and input voltages. The junction temperature range for all DC specifications is 0° C to 100° C. Care should be taken to read all notes associated with each parameter. The $V_{CC_{CORE}}$ tolerances for the LV Intel Pentium III processor 512K are not specified as a percentage of nominal. The tolerances are instead specified in the form of load lines for the static and transient cases in Table 9. An illustration of the load lines is shown in Figure 9.

Table 7. Power Specifications for LV Intel Pentium III Processor 512K

Symbol	Parameter	Frequency (MHz)	Processor Signature	Min	Typ	Max	Unit	Tolerance
$V_{CC_{CORE}}$	Transient $V_{CC_{CORE}}$ for core logic				1.15		V	
$V_{CC_{CORE,DC}}$	Static $V_{CC_{CORE}}$ for core logic				1.15		V	
$V_{CC_{CMOS1.5}}$	1.5 V CMOS voltage				1.5		V	± 10%
$V_{CC_{CMOS1.8}}$	1.8 V CMOS voltage				1.8		V	± 10%
$V_{CC_{CMOS3.3}}$	3.3 V CMOS voltage				3.3		V	± 10%
V_{TT}	VCC for System Bus Buffers, Transient tolerance			1.13	1.25	1.36	V	± 9%
$V_{TT,DC}$	VCC for System Bus Buffers, Static tolerance			1.21	1.25	1.28	V	±3%
$I_{CC_{CORE}}$	Current for $V_{CC_{CORE}}$ at core frequency	1000 933 800	06B2 06B4			10.94 10.5 9.57	A	
I_{TT}	Current for V_{TT}					2.3	A	
$I_{CC_{CMOS1.5}}$	ICC for $V_{CC_{CMOS1.5}}$					250	mA	
$I_{CC_{CMOS1.8}}$	ICC for $V_{CC_{CMOS1.8}}$					1	mA	
$I_{CC_{CMOS3.3}}$	ICC for $V_{CC_{CMOS3.3}}$					35	mA	
$I_{CC_{CORE,SG}}$	Processor Stop Grant current 1.15 V					4.68	A	
I_{LVID}	VID leakage current					0.5	mA	

Figure 8. Power Supply Current Slew Rate ($dI_{CC_{CORE}}/dt$)

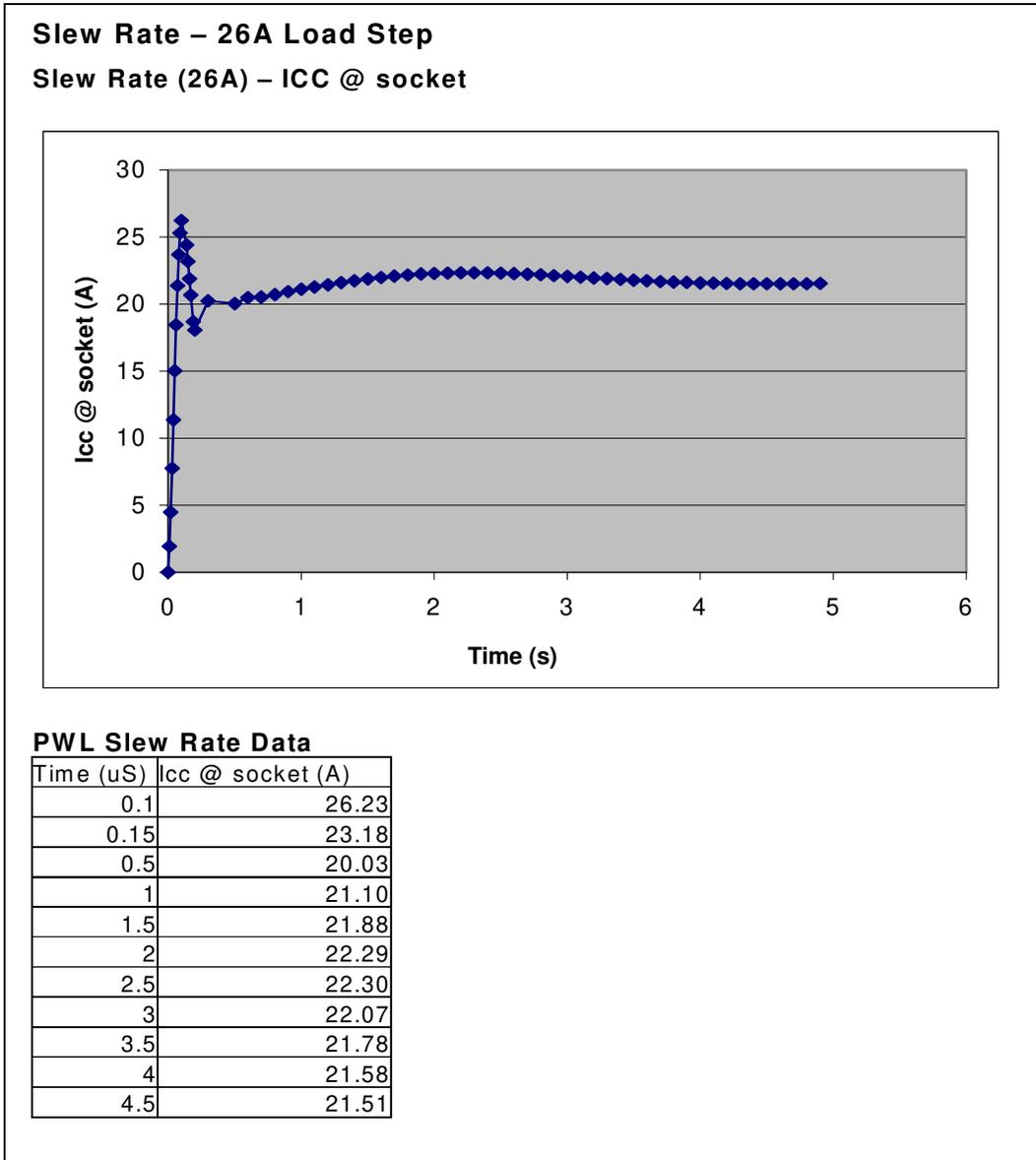
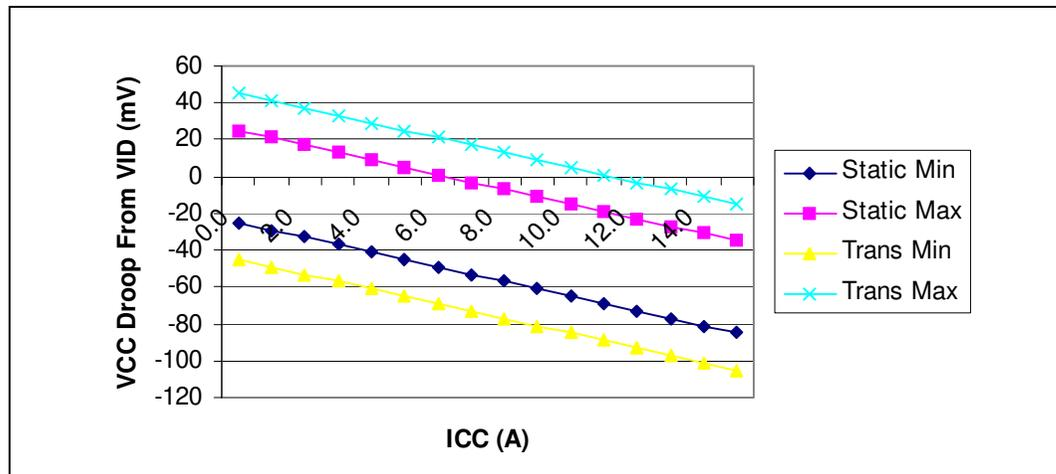

Table 8. VCC_{CORE} Static and Transient Tolerance

I _{CC} (A)	VCC _{CORE} (V)			
	Static Min	Static Max	Trans Min	Trans Max
0.0	-25	25	-45	45
1.0	-29	21	-49	41
2.0	-33	17	-53	37
3.0	-37	13	-57	33
4.0	-41	9	-61	29
5.0	-45	5	-65	25
6.0	-49	1	-69	21
7.0	-53	-3	-73	17
8.0	-57	-7	-77	13
9.0	-61	-11	-81	9
10.0	-65	-15	-85	5
11.0	-69	-19	-89	1
12.0	-73	-23	-93	-3
13.0	-77	-27	-97	-7
14.0	-81	-31	-101	-11
15.0	-85	-35	-105	-15

Figure 9. VCC_{CORE} Static and Transient Tolerance



Note: The VR must meet the specifications defined in Table 8 for every load and load change condition corresponding to the following equations:

- Static minimum regulation requirements: VID set point - 25 mV - (4 mΩ x ICC_{CORE})
- Static maximum regulation requirements: VID set point + 25 mV - (4 mΩ x ICC_{CORE})
- Transient minimum regulation requirements: VID set point - 45 mV - (4 mΩ x ICC_{CORE})
- Transient maximum regulation requirements: VID set point + 45 mV - (4 mΩ x ICC_{CORE})

Table 9. AGTL Signal Group Levels Specifications

Symbol	Parameter	Min	Max	Unit	Notes
V _{IL}	Input Low Voltage		V _{REF} - 0.200	V	
V _{IH}	Input High Voltage	V _{REF} + 0.200		V	1, 2
R _{on}	Buffer On Resistance		16.67	Ω	4
I _L	Leakage Current for inputs, outputs, and I/O		±100	μA	3

NOTES:

1. All inputs, outputs, and I/O balls must comply with the signal quality specifications in [Section 4.0](#).
2. Minimum and maximum V_{TT} are given in [Table 10](#).
3. (0 ≤ V_{IN} ≤ 1.25 V +3%) and (0 ≤ V_{OUT} ≤ 1.25 V+3%).
4. Refer to the processor I/O Buffer Models for I/V characteristics.

Table 10. Processor AGTL Bus Specifications

Symbol	Parameter	Min	Typ	Max	Units	Notes
V _{TT}	Bus Termination Voltage	1.1375	1.25	1.3625	V	1, 2
On-die R _{TT}	Termination Resistor		56 68		Ω	1, 3
V _{REF}	Bus Reference Voltage		2/3V _{TT}		V	1, 4

NOTES:

1. The LV Intel Pentium III processor 512K contains AGTL termination resistors on the processor die, except for the RESET# input.
2. V_{TT} must be held to 1.25V ±9%. It is required that V_{TT} be held to 1.25V ±3% while the processor system bus is idle (static condition). This is measured at the package ball on the Micro-FCBGA part.
3. Uni-processor platforms require a 56 Ω resistor and dual-processor platforms require a 68 Ω resistor. Tolerance for on-die R_{TT} is +/-10%.
4. V_{REF} is generated on the motherboard and should be 2/3 V_{TT} ±5% nominally. Ensure that there is adequate V_{REF} decoupling on the motherboard.

Table 11. CLKREF, APIC, TAP, CMOS, and Open-Drain Signal Group DC Specifications

Symbol	Parameter	Min	Max	Unit	Notes
V_{IL15}	Input Low Voltage, 1.5 V CMOS	-0.15	$V_{CMOS_REFmin} - 300\text{ mV}$	V	
V_{IL18}	Input Low Voltage, 1.8 V CMOS	-0.36	0.36	V	1
V_{IH15}	Input High Voltage, 1.5 V CMOS	$V_{CMOS_REFmax} + 250\text{ mV}$	1.65	V	10
$V_{IH15PICD}$	Input High Voltage, 1.5 V PICD[1:0]	$V_{CMOS_REFmax} + 200\text{ mV}$	1.65	V	11
V_{IH18}	Input High Voltage, 1.8 V CMOS	1.44	2.0	V	1
V_{OH15}	Output High Voltage, 1.5 V CMOS	N/A	1.615	V	12
V_{OH33}	Output High Voltage, 3.3 V signals	2.0	3.465	V	9
V_{OL33}	Output Low Voltage, 3.3 V signals		0.8	V	
V_{OL}	Output Low Voltage		0.3	V	7
V_{CMOS_REF}	CMOSREF Voltage	0.90	1.10	V	3
V_{CLKREF}	CLKREF Voltage	1.187	1.312	V	8
$V_{ILVTPWR}$	Input Low Voltage, VTT_PWRGD		0.4	V	6
$V_{IHVTPWR}$	Input High Voltage, VTT_PWRGD	1.033		V	6
R_{ON}			30	Ω	2
I_{OL}	Output Low Current	10		mA	5
I_L	Leakage Current for Inputs, Outputs and I/Os		± 100	μA	4

NOTES:

1. This parameter applies to the non-AGTL signal PWRGOOD.
2. This value was measured at 9 mA.
3. V_{CMOS_REF} should be created from a stable voltage supply (1.5 V or 1.8 V) using a voltage divider. It must track the voltage supply to maintain noise immunity.
4. ($0 \leq V_{IN/OUT} \leq V_{IHx,max}$)
5. Specified as the minimum amount of current that the output buffer must be able to sink. However, $V_{OL,max}$ cannot be guaranteed if this specification is exceeded.
6. This parameter applies to VTT_PWRGD signal only.
7. This applies to non-AGTL signal PICCLK.
8. $\pm 5\%$ DC tolerance. CLKREF must be generated from a stable source. AC Tolerance must be $< -40\text{dB @ 1 MHz}$.
9. This applies to non-AGTL signals VID[3:0, 25mV] and BSEL[1:0].
10. This applies to all TAP and CMOS signals (not to APIC signals).
11. This applies to PICD[1:0].
12. All outputs are open-drain.

3.11 AC Specifications

3.11.1 System Bus, Clock, APIC, TAP, CMOS, and Open-Drain AC Specifications

The processor system bus timings specified in this section are defined at the processor core (pads).

All system bus AC specifications for the AGTL signal group are relative to the crossing point of the rising edge of the BCLK input and falling edge of the BCLK# input. All AGTL timings are referenced to V_{REF} for both “0” and “1” logic levels unless otherwise specified. All APIC, TAP, CMOS, and open-drain signals except PWRGOOD are referenced to 1.0 V. All minimum and maximum specifications are at points within the power supply ranges shown in Table 6 and junction temperatures (T_j) in the range 0° C to 100° C. T_j must be less than or equal to 100° C for all functional processor states.

Table 12. System Bus Clock AC Specifications (Differential)

Symbol	Parameter	Min	Typ	Max	Unit	Figure	Notes ¹
	System Bus Frequency		133		MHz		
T1	BCLK Period - average	7.5		7.7	ns	12	2
T1abs	BCLK Period – Instantaneous minimum	7.3			ns		2
T2	BCLK Cycle to Cycle Jitter			200	ps		2, 3, 4
T5	BCLK Rise Time	175		467	ps	12	2, 6
T6	BCLK Fall Time	175		467	ps	12	2, 6
	Vcross for 1 V swing	0.51		0.76	V	11	7
	Rise/Fall Time Matching			325	ps		5
	BCLK Duty Cycle	45%		55%			2

NOTES:

1. All AC timings for AGTL and CMOS signals are referenced to the BCLK and BCLK# crossing point.
2. Measured on differential waveform: defined as (BCLK - BCLK#).
3. Not 100% tested. Specified by design/characterization.
4. Due to the difficulty of accurately measuring clock jitter in a system, it is recommended that the clock driver be designed to meet a period stability specification into a test load of 10 to 20 pF. This should be measured on the rising edge of adjacent BCLKs at the BCLK and BCLK# crossing point. The jitter present must be accounted for as a component of BCLK skew between devices. Period difference is measured around 0 V crossing points.
5. Measurement taken from common mode waveform. Measure rise/fall time from 0.41 to 0.86 V. Rise/fall time matching is defined as “the instantaneous difference between maximum BCLK rise (fall) and minimum BCLK# fall (rise) time, or minimum BCLK rise (fall) and maximum BCLK# fall (rise) time”. This parameter is designed to guard waveform symmetry.
6. Rise time is measured from -0.35 V to 0.35 V and fall time is measured from 0.35 V to -0.35 V.
7. Measured on common mode waveform - includes every rise/fall crossing.

Table 13. System Bus Clock AC Specifications (133 MHz, Single-Ended)

Symbol	Parameter	Min	Max	Unit	Figure	Notes ¹
	System Bus Frequency		133		MHz	
T1S	BCLK Period	7.5	7.65	ns	10	2
T1Sabs	BCLK Period – Instantaneous Minimum	7.25				2
T2S	BCLK Period Stability		±250	ps		2, 3, 4
T3S	BCLK High Time	1.4		ns	10	6
T4S	BCLK Low Time	1.4		ns	10	7
T5S	BCLK Rise Time	0.4	1.6	ns	10	5
T6S	BCLK Fall Time	0.4	1.6	ns	10	5

NOTES:

1. All AC timings for GTL+ and CMOS signals are referenced to the BCLK rising edge at 1.25 V.
2. Period, jitter, skew and offset measured at 1.25 V.
3. Not 100% tested. Specified by design/characterization.
4. Measured on the rising edge of adjacent BCLKs at 1.25 V. The jitter present must be accounted for as a component of BCLK skew between devices.
5. Measured between 0.5 V and 2.0 V
6. Measured when the BCLK signal voltage level is above 2.0 V
7. Measured when the BCLK signal voltage level is below 0.5 V

Table 14. Valid LV Intel Pentium III Processor 512K Frequencies

BCLK Frequency (MHz)	Frequency Multiplier	Core Frequency (MHz)	Power-on Configuration bits [27,25:22]
133	6	800	0, 1011
133	7	933	0, 1100
133	8	1000	0, 1101

NOTE: While other combinations of bus and core frequencies are defined, operation at frequencies other than those listed above will not be validated by Intel and are not guaranteed. The frequency multiplier is programmed into the processor when it is manufactured and it cannot be changed.

Table 15. AGTL Signal Groups AC Specifications

R_{TT} internally terminated to V_{TT} ; $V_{REF} = \frac{2}{3}V_{TT}$; load = 50 Ω

Symbol	Parameter	Min	Max	Unit	Figure	Notes ¹
T7	AGTL Output Valid Delay	0.40	3.25	ns	13	
T8	AGTL Input Setup Time	0.95		ns	14	2, 3
T9	AGTL Input Hold Time	1		ns	14	4
T10	RESET# Pulse Width	1		ms	15, 16	5

NOTES:

- All AC timings for AGTL signals are referenced to the crossing point of the BCLK rising edge and the BCLK# falling edge for differential clocking and to the BCLK rising edge at 1.25 V for single-ended clocking. All AGTL signals are referenced at V_{REF} .
- RESET# can be asserted (active) asynchronously, but must be de-asserted synchronously.
- This specification is for a minimum 0.40 V swing from $V_{REF} - 200$ mV to $V_{REF} + 200$ mV.
- This specification is for a maximum 0.80 V swing from $V_{TT} - 0.8$ V to V_{TT} .
- Valid after $V_{CC_{CORE}}$, V_{TT} , and BCLK, BCLK# become stable and PWRGOOD is asserted.

Table 16. CMOS and Open-Drain Signal Groups AC Specifications

Symbol	Parameter	Min	Max	Unit	Figure	Notes ^{1, 2}
T14	1.5 V Input Pulse Width, except PWRGOOD and LINT[1:0]	2		BCLKs	15	5
T14B	LINT[1:0] Input Pulse Width	6		BCLKs	15	3
T15	PWRGOOD Inactive Pulse Width	2		μ s	16	4

NOTES:

- All AC timings for CMOS and open-drain signals are referenced to the crossing point of the BCLK rising edge and BCLK# falling edge for Differential Clocking and to the rising edge of BCLK at 1.25 V for single-ended clocking. All CMOS and open-drain signals are referenced at 1.0 V.
- Minimum output pulse width on CMOS outputs is two BCLKs.
- This specification only applies when the APIC is enabled and the LINT1 or LINT0 signal is configured as an edge triggered interrupt with fixed delivery, otherwise specification T14 applies.
- When driven inactive, or after $V_{CC_{CORE}}$, V_{TT} and BCLK, BCLK# become stable. PWRGOOD must remain below $V_{IL18,MAX}$ until all the voltage planes meet the voltage tolerance specifications in Table 9 and BCLK, BCLK# have met the BCLK, BCLK# AC specifications in Table 20 and Table 21 for at least 2 μ s. PWRGOOD must rise error-free and monotonically to 1.8 V.
- For active and inactive states

Table 17. Reset Configuration AC Specifications and Power On Timings

Symbol	Parameter	Min	Typ	Max	Unit	Figure	Notes
T16	Reset Configuration Signals (A[15:5]#, BR0#, FLUSH#, INIT#, PICD0) Setup Time	4			BCLKs	15	1
T17	Reset Configuration Signals (A[15:5]#, BR0#, FLUSH#, INIT#, PICD0) Hold Time	2		20	BCLKs	15	2
T18	RESET#/PWRGOOD Setup Time	1			ms	16	1, 3
T18A	V _{TT} to VTT_PWRGD Setup Time	1			ms	16	
T18B	VCC _{CORE} to PWRGOOD Setup Time		10		ms	16	
T18C	BSEL, VID valid time before VTT_PWRGD assertion	1			μs	16	
T18D	RESET# inactive to Valid Outputs	1			BCLK	15	
T18E	RESET# inactive to Drive Signals	4			BCLKs	15	

NOTE:

1. Applies before deassertion of RESET#
2. Applies after clock that deasserts RESET#
3. At least 1 ms must pass after PWRGOOD rises above V_{IH18min} and BCLK, BCLK# meet their AC timing specification until RESET# may be deasserted.

Table 18. APIC Bus Signal AC Specifications

Symbol	Parameter	Min	Max	Unit	Figure	Notes ¹
T21	PICCLK Frequency	2	33.3	MHz		2
T22	PICCLK Period	30	500	ns	10	
T23	PICCLK High Time	10.5		ns	10	5
T24	PICCLK Low Time	10.5		ns	10	6
T25	PICCLK Rise Time	0.25	3.0	ns	10	7
T26	PICCLK Fall Time	0.25	3.0	ns	10	8
T27	PICD[1:0] Setup Time	8.0		ns	13	3
T28	PICD[1:0] Hold Time	2.5		ns	13	3
T29	PICD[1:0] Valid Delay (Rising Edge)	1.5	8.7	ns	12	3, 4
	PICD[1:0] Valid Delay (Falling Edge)	1.5	12.0			

NOTES:

1. All AC timings for APIC signals are referenced to the PICCLK rising edge at 1.0 V. All CMOS signals are referenced at 1.0 V.
2. The minimum frequency is 2 MHz when PICD0 is at 1.5 V at reset Referenced to PICCLK Rising Edge.
3. For open-drain signals, Valid Delay is synonymous with Float Delay.
4. Valid delay timings for these signals are specified into 150 Ω to 1.5 V and 0 pF of external load. For real system timings these specifications must be derated for external capacitance at 105 ps/pF.
5. Measured when the PICCLK signal voltage level is above 1.6 V
6. Measured when the PICCLK signal voltage level is below 1.6 V
7. Measured from 0.4 V to 1.6 V
8. Measured from 1.6 V to 0.4 V

Table 19. TAP Signal AC Specifications

Symbol	Parameter	Min	Max	Unit	Figure	Notes ¹
T30	TCK Frequency	—	16.67	MHz		
T31	TCK Period	60	—	ns	10	
T32	TCK High Time	25.0		ns	10	2, 9
T33	TCK Low Time	25.0		ns	10	2, 10
T34	TCK Rise Time		5.0	ns	10	2, 3, 11
T35	TCK Fall Time		5.0	ns	10	2, 3, 12
T36	TRST# Pulse Width	40.0		ns	18	2
T37	TDI, TMS Setup Time	5.0		ns	17	4
T38	TDI, TMS Hold Time	14.0		ns	17	4
T39	TDO Valid Delay	1.0	10.0	ns	17	5, 6
T40	TDO Float Delay		25.0	ns	17	2, 5, 6
T41	All Non-Test Outputs Valid Delay	2.0	25.0	ns	17	5, 7, 8
T42	All Non-Test Outputs Float Delay		25.0	ns	17	2, 5, 7, 8
T43	All Non-Test Inputs Setup Time	5.0		ns	17	4, 7, 8
T44	All Non-Test Inputs Hold Time	13.0		ns	17	4, 7, 8

NOTES:

- All AC timings for TAP signals are referenced to the TCK rising edge at 1.0 V. All TAP and CMOS signals are referenced at 1.0 V.
- Not 100% tested. Specified by design/characterization.
- 1 ns can be added to the maximum TCK rise and fall times for every 1 MHz below 16 MHz.
- Referenced to TCK rising edge
- Referenced to TCK falling edge
- Valid delay timing for this signal is specified into 150 Ω terminated to 1.5 V and 0 pF of external load. For real system timings these specifications must be derated for external capacitance at 105 ps/pF.
- Non-Test Outputs and Inputs are the normal output or input signals (except TCK, TRST#, TDI, TDO, and TMS). These timings correspond to the response of these signals due to boundary scan operations.
- During Debug Port operation use the normal specified timings rather than the TAP signal timings.
- Measured when the TCK signal voltage level is at or above $V_{\text{CMOS_REF}} + 0.2 \text{ V}$.
- Measured when the TCK signal voltage level is at or below $V_{\text{CMOS_REF}} - 0.2 \text{ V}$.
- Measured from $V_{\text{CMOS_REF}} - 0.2 \text{ V}$ to $V_{\text{CMOS_REF}} + 0.2 \text{ V}$
- Measured from $V_{\text{CMOS_REF}} + 0.2 \text{ V}$ to $V_{\text{CMOS_REF}} - 0.2 \text{ V}$

Figure 10. BCLK (Single Ended)/PICCLK/TCK Generic Clock Timing Waveform

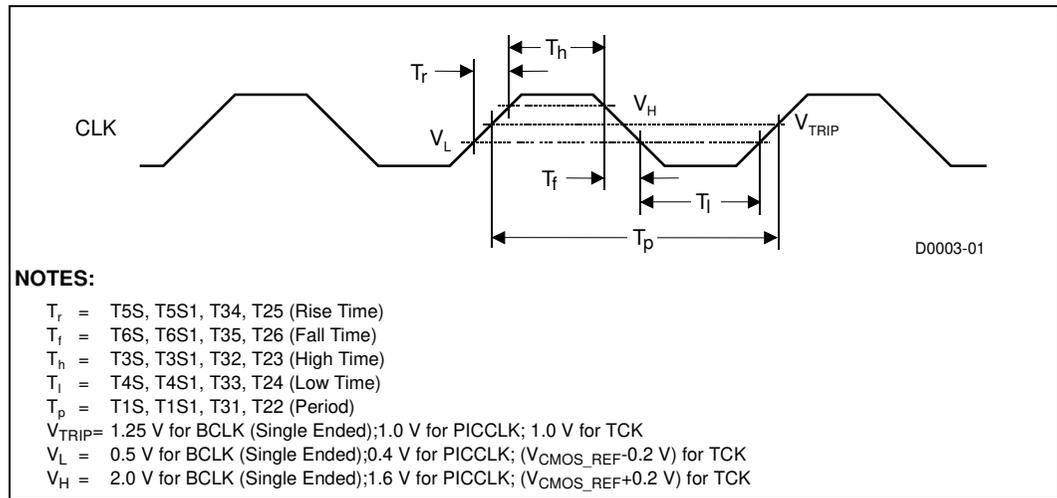

Figure 11. Differential BCLK/BCLK# Waveform (Common Mode)

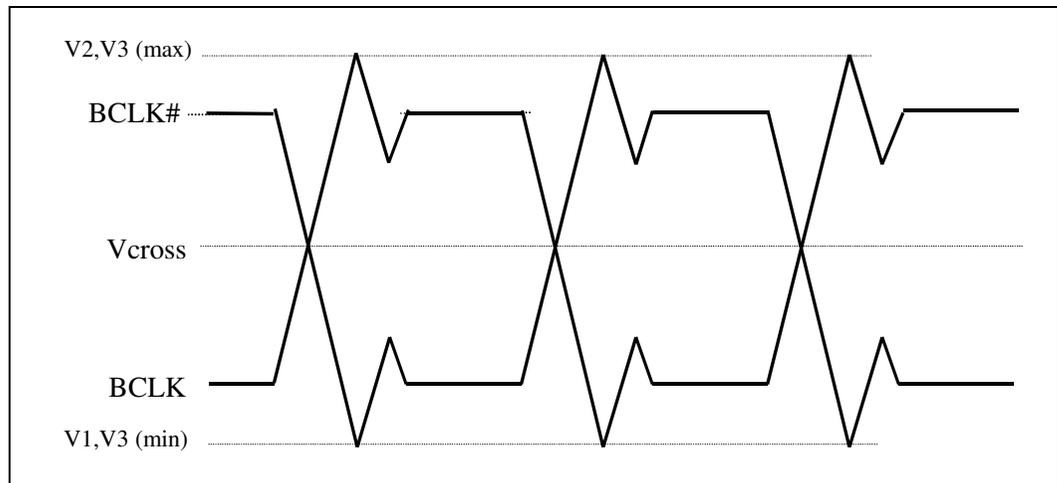

Figure 12. BCLK/BCLK# Waveform (Differential Mode)

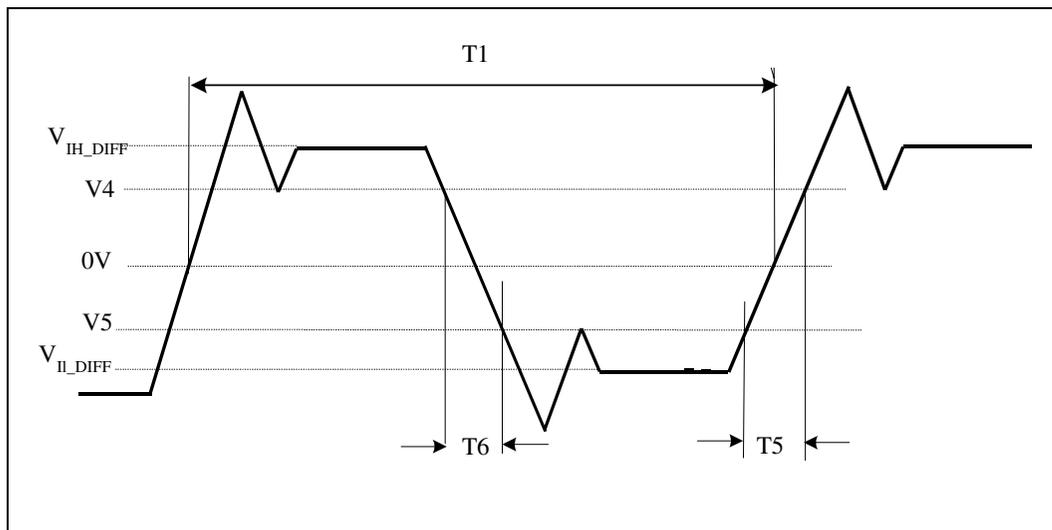

Figure 13. Valid Delay Timings

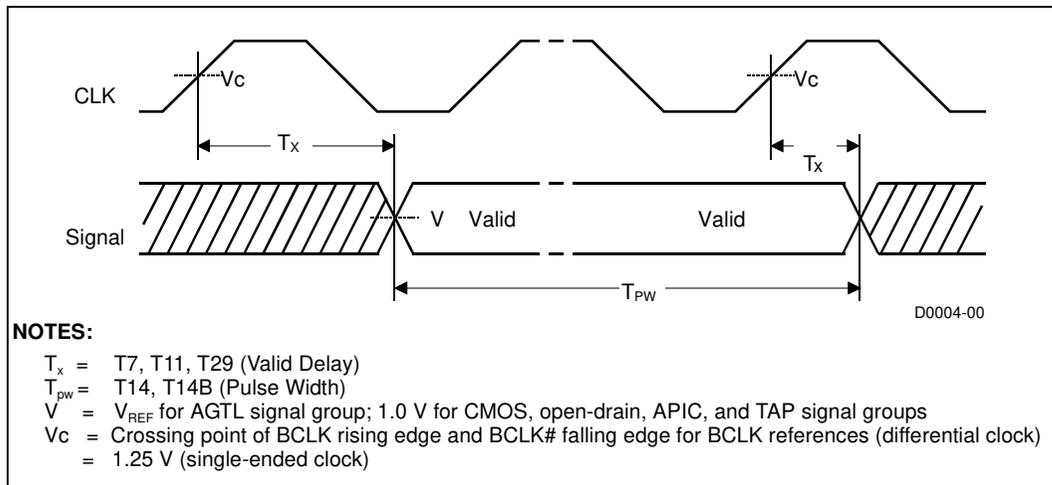

Figure 14. Setup and Hold Timings

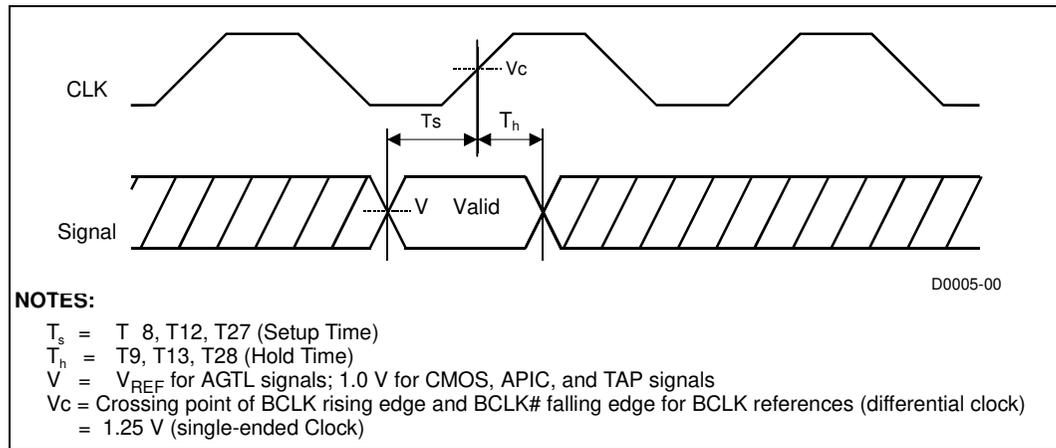

Figure 15. Cold/Warm Reset and Configuration Timings

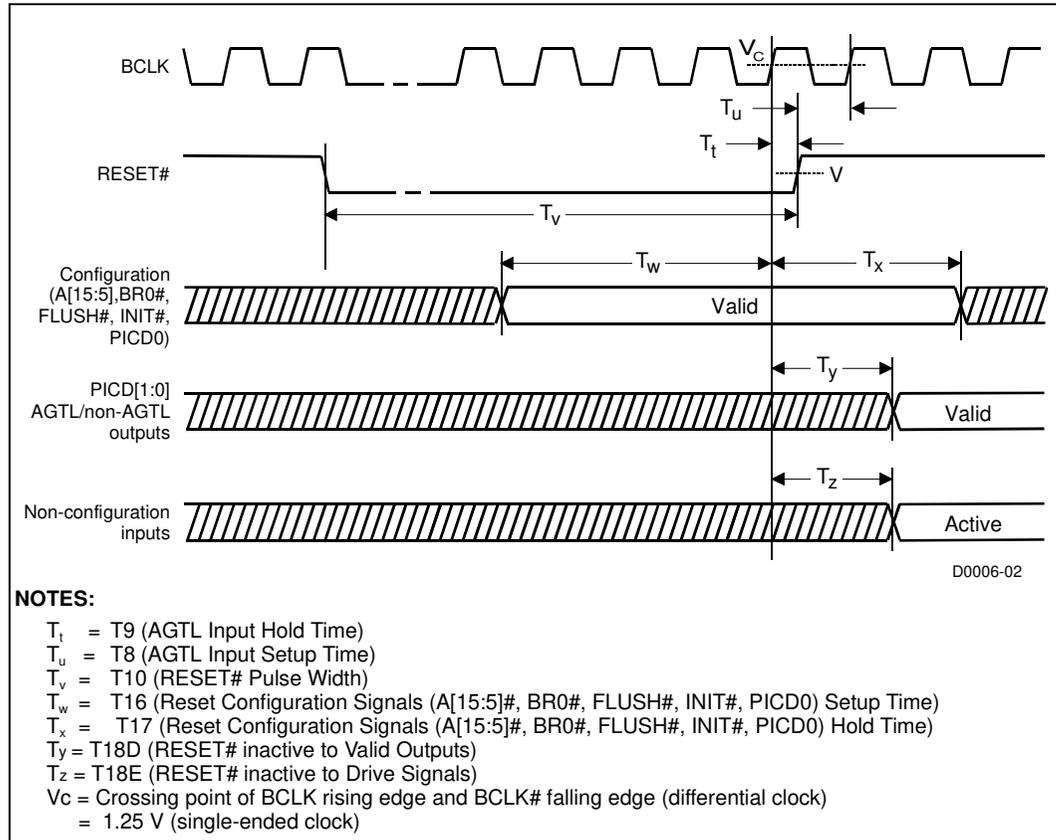

Figure 16. Power-On Sequence and Reset Timings

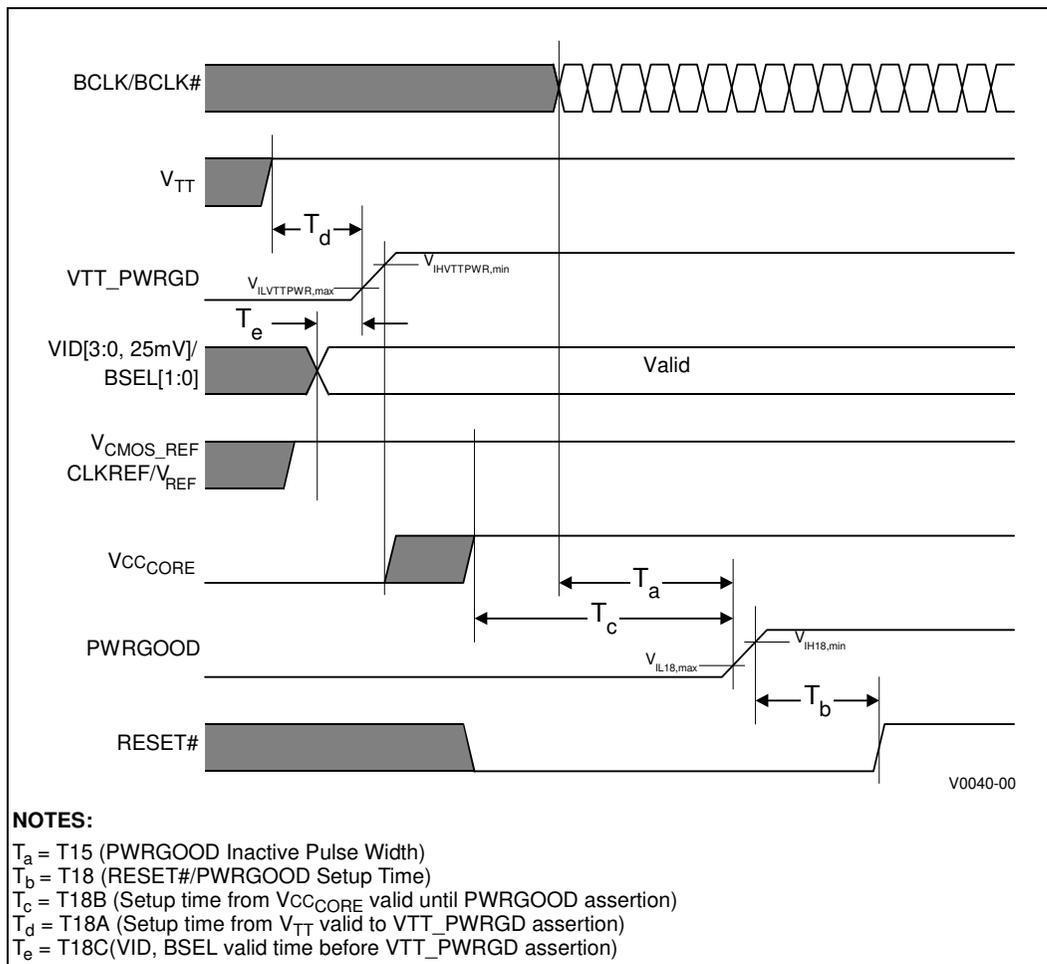

Figure 17. Test Timings (Boundary Scan)

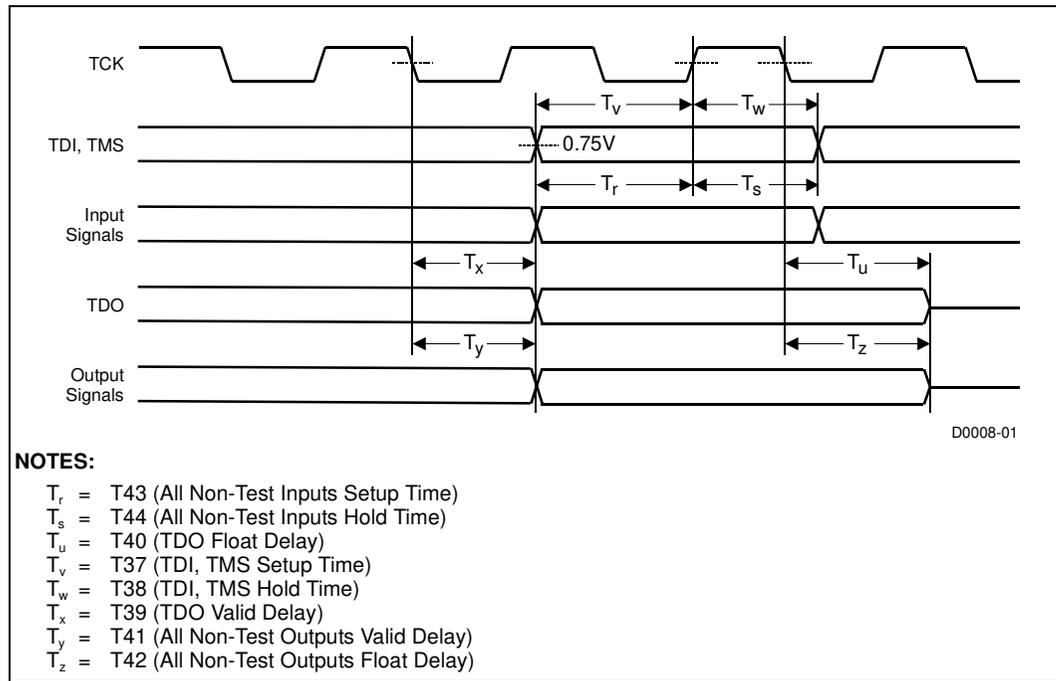
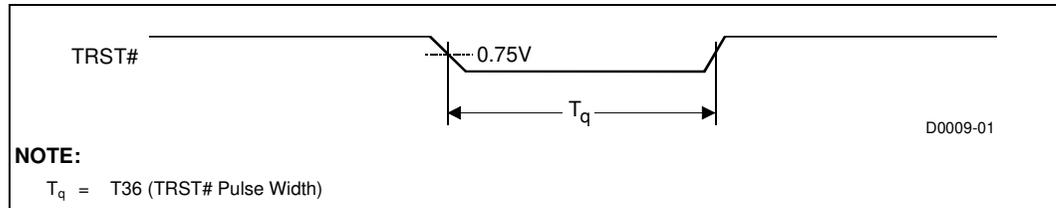

Figure 18. Test Reset Timings



4.0 System Signal Simulations

Systems must be simulated using the LV Intel Pentium III processor 512K IBIS Models to determine if they are compliant with this specification. All references to BCLK signal quality also apply to BCLK# for differential clocking.

4.1 System Bus Clock (BCLK) and PICCLK DC Specifications and AC Signal Quality Specifications

Table 20. BCLK (Differential) DC Specifications and AC Signal Quality Specifications

Symbol	Parameter	Min	Max	Unit	Figure	Notes
V1	$V_{IL,BCLK}$	-0.2	0.35	V	11	1
V2	$V_{IH,BCLK}$	0.92	1.45	V	11	1
V3	V_{IN} Absolute Voltage Range	-0.2	1.45	V	11	2, 4
V4	BCLK Rising Edge Ringback	0.35		V	12	3
V5	BCLK Falling Edge Ringback		-0.35	V	12	3

NOTES:

1. The clock must rise/fall monotonically between $V_{IL,BCLK}$ and $V_{IH,BCLK}$.
2. These specifications apply only when BCLK, BCLK# are running.
3. The rising and falling edge ringback voltage specified is the minimum (rising) or maximum (falling) voltage the differential waveform can go to after passing the V_{IH_DIFF} (rising) or V_{IL_DIFF} (falling) levels.
4. For undershoot and overshoot

Table 21. BCLK (Single-Ended) DC Specifications and AC Signal Quality Specifications

Symbol	Parameter	Min	Max	Unit	Figure	Notes
V1	$V_{IL,BCLK}$		0.3	V	19	1
V2	$V_{IH,BCLK}$	2.2		V	19	1
V3	V_{IN} Absolute Voltage Range	-0.5	3.1	V	19	2, 4
V4	BCLK Rising Edge Ringback	2.0		V	19	3, 5
V5	BCLK Falling Edge Ringback		0.5	V	19	3, 5

NOTES:

1. The clock must rise/fall monotonically between $V_{IL,BCLK}$ and $V_{IH,BCLK}$. BCLK must be stopped in the low state.
2. These specifications apply only when BCLK is running. BCLK may not be above $V_{IH,BCLK,max}$ or below $V_{IL,BCLK,min}$ for more than 50% of the clock cycle.
3. The rising and falling edge ringback voltage specified is the minimum (rising) or maximum (falling) absolute voltage the BCLK signal can go to after passing the $V_{IH,BCLK}$ (rising) or $V_{IL,BCLK}$ (falling) voltage limits.
4. For overshoot and undershoot.
5. Absolute value

Table 22. PICCLK DC Specifications and AC Signal Quality Specifications

Symbol	Parameter	Min	Max	Unit	Figure	Notes
V1	V_{IL20}		0.4	V	19	1
V2	V_{IH20}	1.6		V	19	1
V3	V_{IN} Absolute Voltage Range	-0.4	2.4	V	19	2, 4
V4	PICCLK Rising Edge Ringback	1.6		V	19	3, 5
V5	PICCLK Falling Edge Ringback		0.4	V	19	3, 5

NOTES:

1. The clock must rise/fall monotonically between V_{IL20} and V_{IH20} .
2. These specifications apply only when PICCLK is running. See the DC specifications for when PICCLK is stopped. PICCLK may not be above $V_{IH20,max}$ or below $V_{IL20,min}$ for more than 50% of the clock cycle.
3. The rising and falling edge ringback voltage specified is the minimum (rising) or maximum (falling) absolute voltage the PICCLK signal can go to after passing the V_{IH20} (rising) or V_{IL20} (falling) voltage limits.
4. For overshoot and undershoot
5. Absolute value

Figure 19. BCLK (Single-Ended)/PICCLK Generic Clock Waveform

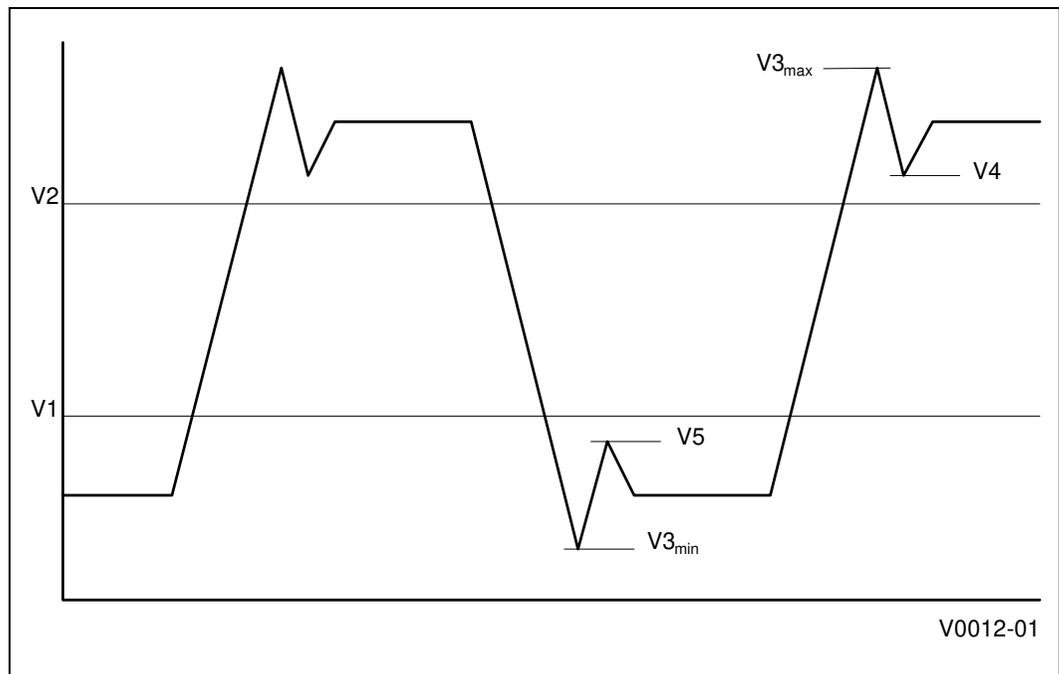

4.2 AGTL AC Signal Quality Specifications

The ringback specifications for the AGTL signals are as follows:

- Ringback below $V_{REF,max} + 200$ mV is not authorized during low to high transitions.
- Ringback above $V_{REF,min} - 200$ mV is not authorized during high to low transitions.

Overshoot and undershoot specifications are documented in Table 23 and illustrated in Figure 20.

Figure 20. Maximum Acceptable Overshoot/Undershoot Waveform

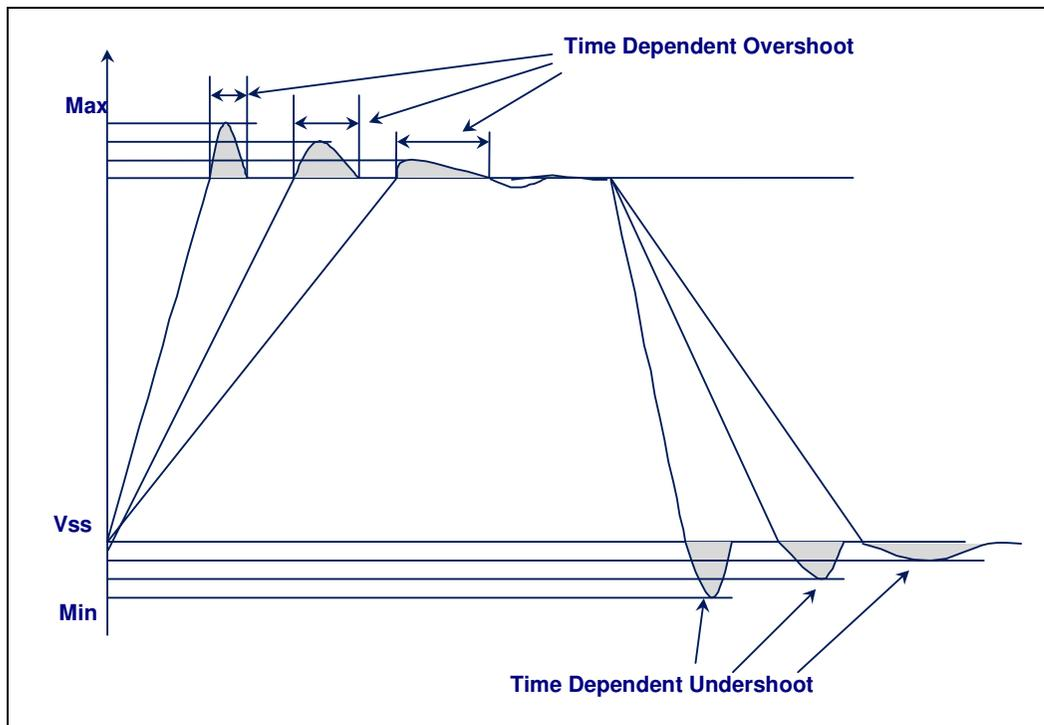

Table 23. 133 MHz AGTL Signal Group Overshoot/Undershoot Tolerance at the Processor Core

Max V_{TT} + Overshoot/Undershoot Magnitude (volts)	Allowed Pulse Duration (ns) [$T_J=100^\circ\text{C}$]		
	Activity Factor = 0.01	Activity Factor = 0.1	Activity Factor = 1
1.78	1.5	0.15	0.015
1.73	3.5	0.35	0.035
1.68	7.2	0.72	0.072
1.63	15	1.5	0.15
1.58	15	3.2	0.32
1.53	15	6.5	0.65
1.48	15	14	1.40

NOTES:

- Under no circumstances should the sum of the Max V_{TT} and absolute value of the Overshoot/Undershoot voltage exceed 1.78 V.
- Activity factor of 1 represents the same toggle rate as the 133-MHz clock.
- Ringbacks below V_{TT} cannot be subtracted from overshoots. Lesser undershoot does not allocate longer or larger overshoot.
- Ringbacks above ground cannot be subtracted from undershoots. Lesser overshoot does not allocate longer or larger undershoot.
- System designers are encouraged to follow Intel provided AGTL layout guidelines.
- All values are specified by design characterization and are not tested.

4.3 Non-AGTL Signal Quality Specifications

Signals driven to the LV Intel Pentium III processor 512K should meet signal quality specifications to ensure that the processor reads data properly and that incoming signals do not affect the long-term reliability of the processor. The overshoot and undershoot specifications for non AGTL signals are shown in [Table 24](#).

Table 24. Non-AGTL Signal Group Overshoot/Undershoot Tolerance at the Processor Core

Max V_{CMOS} + Overshoot/Undershoot Magnitude (volts)	Allowed Pulse Duration (ns) [$T_J=100^\circ\text{C}$]		
	Activity Factor = 0.01	Activity Factor = 0.1	Activity Factor = 1
2.38	6.5	0.65	0.065
2.33	13	1.3	0.13
2.28	29	2.9	0.29
2.23	60	6	0.6
2.18	60	12	1.2
2.13	60	26	2.6
2.08	60	56	5.6

NOTES:

- V_{CMOS} (nominal) = 1.5 V
- Under no circumstances should the sum of the Max V_{CMOS} and absolute value of the Overshoot/Undershoot voltage exceed 2.38 V.
- Activity factor of 1 represents a toggle rate of 33 MHz
- System designers are encouraged to follow Intel provided non-AGTL layout guidelines.
- All values are specified by design characterization, and are not tested.

4.3.1 PWRGOOD Signal Quality Specification

The processor requires PWRGOOD to be a clean indication that clocks and the power supplies ($V_{CC_{CORE}}$, V_{TT} , etc.) are stable and within their specifications. Clean implies that the signal will remain below V_{IL18} and without errors from the time that the power supplies are turned on, until they come within specification. The signal will then transition monotonically to a high (1.8 V) state.

4.3.2 VTT_PWRGD Signal Quality Specification

The VTT_PWRGD signal is an input to the processor that is used to determine that the V_{TT} power is stable and that the VID and BSEL signals should be driven to their final states by the processor. To ensure the processor correctly reads this signal, it must meet the following requirement while the signal is in its transition region of 300 mV to 900 mV:

Parameter	Specification
Amount of Noise (Glitch)	Less than 100 mV

VTT_PWRGD should only enter the transition region once, after V_{TT} is at nominal voltage, for the assertion of the signal. In addition, the VTT_PWRGD signal should have reasonable transition time through the transition region. A sharp edge on the signal transition minimizes the chance of noise causing a glitch on this signal. Intel recommends the following transition time for the VTT_PWRGD signal:

Parameter	Specification
Transition Time (300 mV to 900 mV)	Less than or equal to 100 μ s

4.3.2.1 Transition Region

The transition region covered by this requirement is 300 mV to 900 mV. Once the VTT_PWRGD signal is in that voltage range, the processor is more sensitive to noise that may be present on the signal. The transition region begins when the signal first crosses the 300 mV voltage level and ends before the signal crosses 900 mV.

4.3.2.2 Transition Time

The transition time is defined as the time the signal takes to move through the transition region. A 100 μ s transition time ensures that the processor receives a good transition edge.

4.3.2.3 Noise

The signal quality of the VTT_PWRGD signal is critical to the correct operation of the processor. Every effort should be made to ensure this signal is monotonic in the transition region. If noise or glitches are present on this signal, it must be kept to less than 100 mV of a voltage drop from the highest voltage level received to that point. This glitch must remain less than 100 mV until the excursion ends. The excursion ends when the voltage returns to the highest voltage previously received. [Figure 21](#) provides an example graph of this situation and requirements.

Figure 21. Noise Estimation

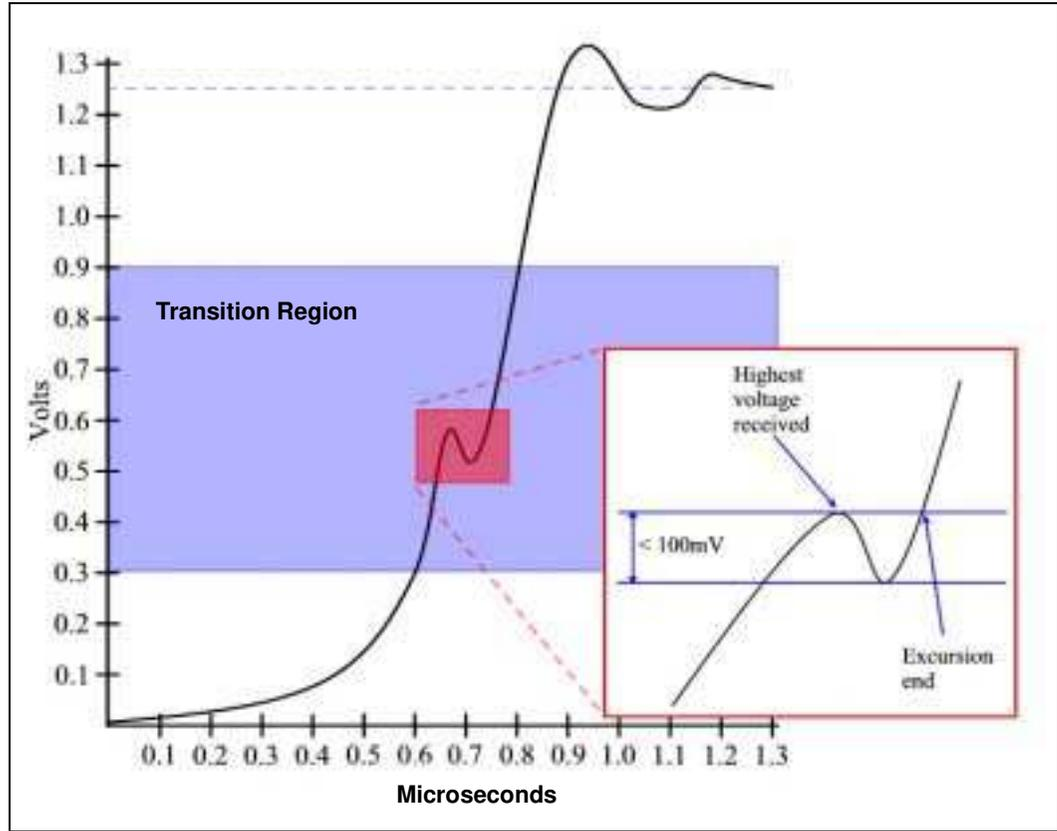

5.0 Mechanical Specifications

5.1 Surface Mount Micro-FCBGA Package

The LV Intel Pentium III processor 512K is available in a surface mount, 479-ball Micro-FCBGA package. Mechanical specifications are shown in Table 25. Figure 22 through Figure 25 illustrate different views of the package.

The Micro-FCBGA package may have capacitors placed in the area surrounding the die. Because the die-side capacitors are electrically conductive, and only slightly shorter than the die height, care should be taken to avoid placing the capacitors in contact with electrically conductive materials. Doing so may short the capacitors, and can damage the device or render it inactive. Consider using an insulating material between the capacitors and the thermal solution to prevent shorting the capacitor.

Table 25. Micro-FCBGA Package Mechanical Specifications

Symbol	Parameter	Min	Max	Unit
A	Overall height, as delivered (1)	2.27	2.77	mm
A2	Die height	0.854		mm
b	Ball diameter	0.78		mm
D	Package substrate length	34.9	35.1	mm
E	Package substrate width	34.9	35.1	mm
D1	Die length	11.18		mm
E1	Die width	7.19		mm
e	Ball pitch	1.27		mm
N	Ball count	479		each
K	Keep-out outline from edge of package	5		mm
K1	Keep-out outline at corner of package	7		mm
K2	Capacitor keep-out height	—	0.7	mm
S	Package edge to first ball center	1.625		mm
--	Solder ball coplanarity	0.2		mm
Pdie	Allowable pressure on the die for thermal solution	—	689	kPa
W	Package weight	4.5		g

NOTES:

1. All dimensions are subject to change.
2. Overall height as delivered. Values were based on design specifications and tolerances. Final height after surface mount depends on OEM motherboard design and SMT process.

Note: All dimensions are in millimeters. Values shown are for reference only.

Figure 22. Micro-FCBGA Package – Top and Bottom Isometric Views

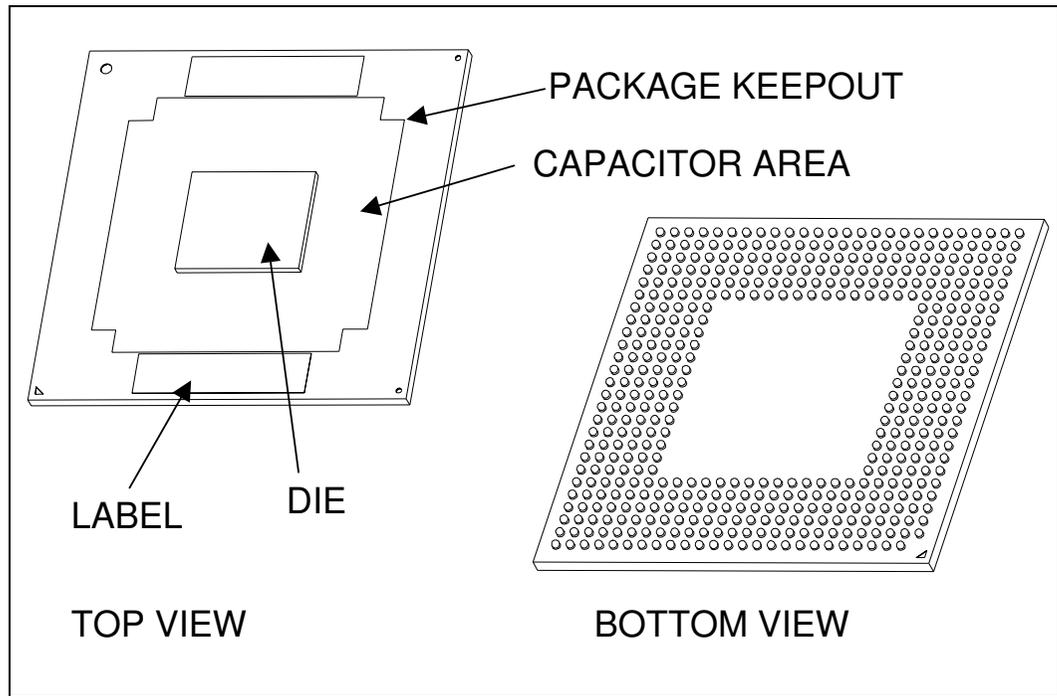

Figure 23. Micro-FCBGA Package – Top and Side Views

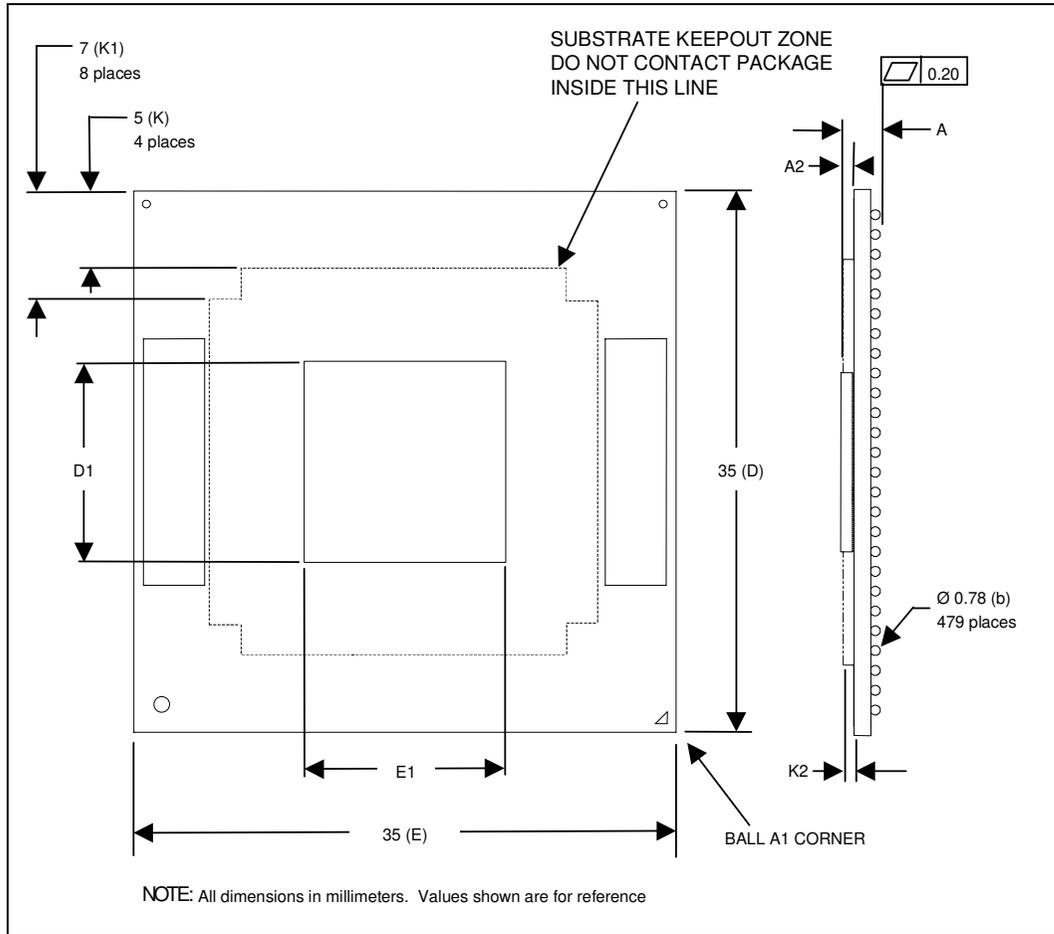
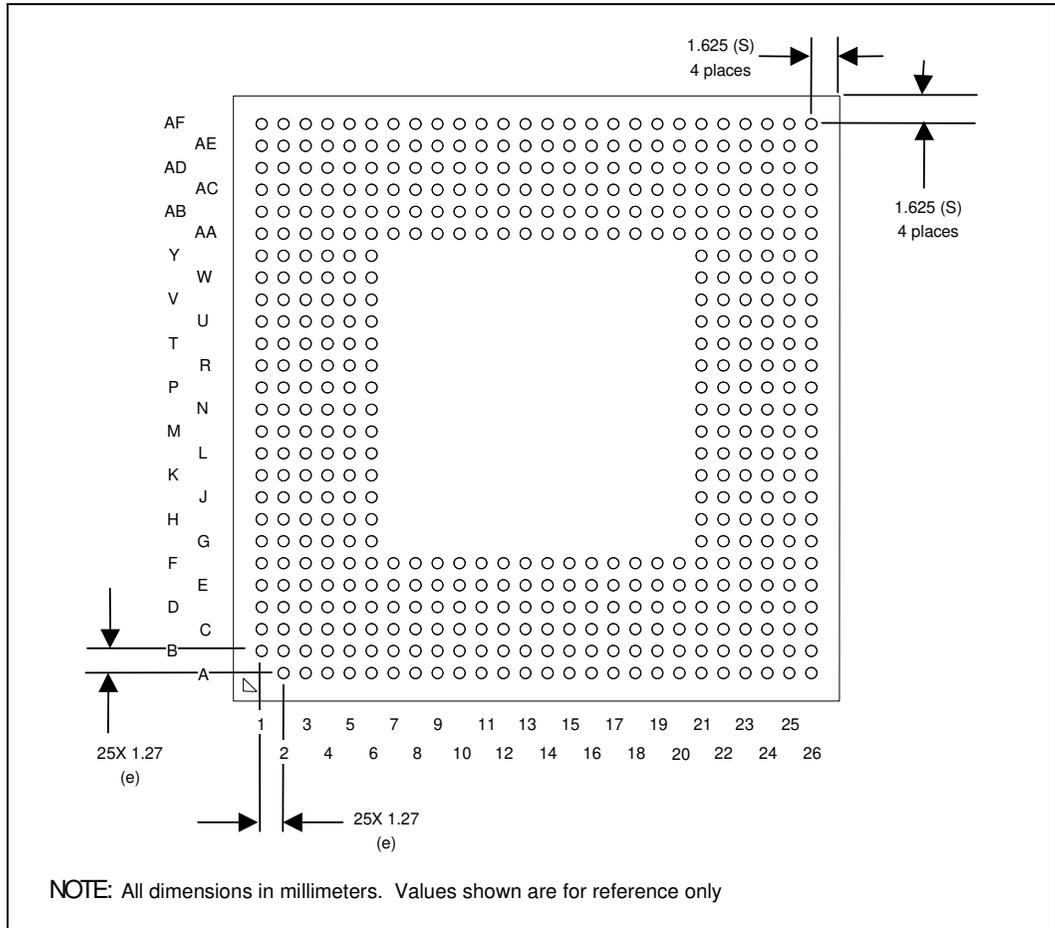

Figure 24. Micro-FCBGA Package - Bottom View



5.2 Signal Listings

Figure 22 is a top-side view of the ball map of the LV Intel Pentium III processor 512K with the voltage balls called out. Table 26 lists the signals in ball number order. Table 27 lists the signals in signal name order.

Figure 25. Ball Map - Top View

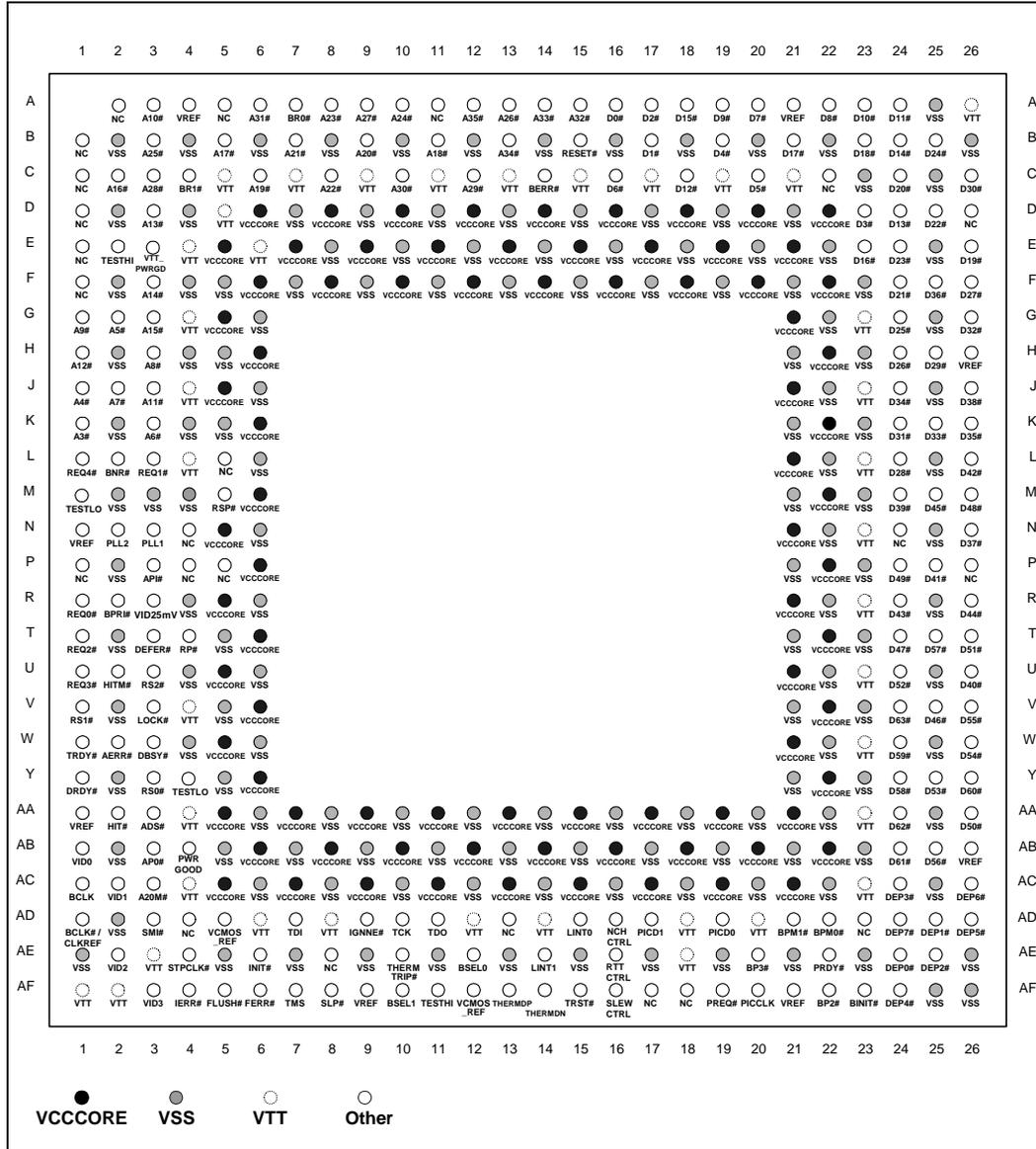

Table 26. Signal List by Ball Number

No.	Signal Name
A2	NC
A3	A10#
A4	VREF
A5	NC
A6	A31#
A7	BR0#
A8	A23#
A9	A27#
A10	A24#
A11	NC
A12	A35#
A13	A26#
A14	A33#
A15	A32#
A16	D0#
A17	D2#
A18	D15#
A19	D9#
A20	D7#
A21	VREF
A22	D8#
A23	D10#
A24	D11#
A25	VSS
A26	VTT
B1	NC
B2	VSS
B3	A25#
B4	VSS
B5	A17#
B6	VSS
B7	A21#
B8	VSS
B9	A20#
B10	VSS
B11	A18#
B12	VSS
B13	A34#
B14	VSS
B15	RESET#
B16	VSS

Table 26. Signal List by Ball Number

No.	Signal Name
B17	D1#
B18	VSS
B19	D4#
B20	VSS
B21	D17#
B22	VSS
B23	D18#
B24	D14#
B25	D24#
B26	VSS
C1	NC
C2	A16#
C3	A28#
C4	BR1#
C5	VTT
C6	A19#
C7	VTT
C8	A22#
C9	VTT
C10	A30#
C11	VTT
C12	A29#
C13	VTT
C14	BERR#
C15	VTT
C16	D6#
C17	VTT
C18	D12#
C19	VTT
C20	D5#
C21	VTT
C22	NC
C23	VSS
C24	D20#
C25	VSS
C26	D30#
D1	NC
D2	VSS
D3	A13#
D4	VSS
D5	VTT

Table 26. Signal List by Ball Number

No.	Signal Name
D6	VCCCORE
D7	VSS
D8	VCCCORE
D9	VSS
D10	VCCCORE
D11	VSS
D12	VCCCORE
D13	VSS
D14	VCCCORE
D15	VSS
D16	VCCCORE
D17	VSS
D18	VCCCORE
D19	VSS
D20	VCCCORE
D21	VSS
D22	VCCCORE
D23	D3#
D24	D13#
D25	D22#
D26	NC
E1	NC
E2	TESTHI
E3	VTT_PWRGD
E4	VTT
E5	VCCCORE
E6	VTT
E7	VCCCORE
E8	VSS
E9	VCCCORE
E10	VSS
E11	VCCCORE
E12	VSS
E13	VCCCORE
E14	VSS
E15	VCCCORE
E16	VSS
E17	VCCCORE
E18	VSS
E19	VCCCORE
E20	VSS

Table 26. Signal List by Ball Number

No.	Signal Name
E21	VCCCORE
E22	VSS
E23	D16#
E24	D23#
E25	VSS
E26	D19#
F1	NC
F2	VSS
F3	A14#
F4	VSS
F5	VSS
F6	VCCCORE
F7	VSS
F8	VCCCORE
F9	VSS
F10	VCCCORE
F11	VSS
F12	VCCCORE
F13	VSS
F14	VCCCORE
F15	VSS
F16	VCCCORE
F17	VSS
F18	VCCCORE
F19	VSS
F20	VCCCORE
F21	VSS
F22	VCCCORE
F23	VSS
F24	D21#
F25	D36#
F26	D27#
G1	A9#
G2	A5#
G3	A15#
G4	VTT
G5	VCCCORE
G6	VSS
G21	VCCCORE
G22	VSS
G23	VTT

Table 26. Signal List by Ball Number

No.	Signal Name
G24	D25#
G25	VSS
G26	D32#
H1	A12#
H2	VSS
H3	A8#
H4	VSS
H5	VSS
H6	VCCCORE
H21	VSS
H22	VCCCORE
H23	VSS
H24	D26#
H25	D29#
H26	VREF
J1	A4#
J2	A7#
J3	A11#
J4	VTT
J5	VCCCORE
J6	VSS
J21	VCCCORE
J22	VSS
J23	VTT
J24	D34#
J25	VSS
J26	D38#
K1	A3#
K2	VSS
K3	A6#
K4	VSS
K5	VSS
K6	VCCCORE
K21	VSS
K22	VCCCORE
K23	VSS
K24	D31#
K25	D33#
K26	D35#
L1	REQ4#
L2	BNR#

Table 26. Signal List by Ball Number

No.	Signal Name
L3	REQ1#
L4	VTT
L5	NC
L6	VSS
L21	VCCCORE
L22	VSS
L23	VTT
L24	D28#
L25	VSS
L26	D42#
M1	TESTLO
M2	VSS
M3	VSS
M4	VSS
M5	RSP#
M6	VCCCORE
M21	VSS
M22	VCCCORE
M23	VSS
M24	D39#
M25	D45#
M26	D48#
N1	VREF
N2	PLL2
N3	PLL1
N4	NC
N5	VCCCORE
N6	VSS
N21	VCCCORE
N22	VSS
N23	VTT
N24	NC
N25	VSS
N26	D37#
P1	NC
P2	VSS
P3	AP1#
P4	NC
P5	NC
P6	VCCCORE
P21	VSS

Table 26. Signal List by Ball Number

No.	Signal Name
P22	VCCCORE
P23	VSS
P24	D49#
P25	D41#
P26	NC
R1	REQ0#
R2	BPRI#
R3	VID25mV
R4	VSS
R5	VCCCORE
R6	VSS
R21	VCCCORE
R22	VSS
R23	VTT
R24	D43#
R25	VSS
R26	D44#
T1	REQ2#
T2	VSS
T3	DEFER#
T4	RP#
T5	VSS
T6	VCCCORE
T21	VSS
T22	VCCCORE
T23	VSS
T24	D47#
T25	D57#
T26	D51#
U1	REQ3#
U2	HITM#
U3	RS2#
U4	VSS
U5	VCCCORE
U6	VSS
U21	VCCCORE
U22	VSS
U23	VTT
U24	D52#
U25	VSS
U26	D40#

Table 26. Signal List by Ball Number

No.	Signal Name
V1	RS1#
V2	VSS
V3	LOCK#
V4	VTT
V5	VSS
V6	VCCCORE
V21	VSS
V22	VCCCORE
V23	VSS
V24	D63#
V25	D46#
V26	D55#
W1	TRDY#
W2	AERR#
W3	DBSY#
W4	VSS
W5	VCCCORE
W6	VSS
W21	VCCCORE
W22	VSS
W23	VTT
W24	D59#
W25	VSS
W26	D54#
Y1	DRDY#
Y2	VSS
Y3	RS0#
Y4	TESTLO
Y5	VSS
Y6	VCCCORE
Y21	VSS
Y22	VCCCORE
Y23	VSS
Y24	D58#
Y25	D53#
Y26	D60#
AA1	VREF
AA2	HIT#
AA3	ADS#
AA4	VTT
AA5	VCCCORE

Table 26. Signal List by Ball Number

No.	Signal Name
AA6	VSS
AA7	VCCCORE
AA8	VSS
AA9	VCCCORE
AA10	VSS
AA11	VCCCORE
AA12	VSS
AA13	VCCCORE
AA14	VSS
AA15	VCCCORE
AA16	VSS
AA17	VCCCORE
AA18	VSS
AA19	VCCCORE
AA20	VSS
AA21	VCCCORE
AA22	VSS
AA23	VTT
AA24	D62#
AA25	VSS
AA26	D50#
AB1	VID0
AB2	VSS
AB3	AP0#
AB4	PWRGOOD
AB5	VSS
AB6	VCCCORE
AB7	VSS
AB8	VCCCORE
AB9	VSS
AB10	VCCCORE
AB11	VSS
AB12	VCCCORE
AB13	VSS
AB14	VCCCORE
AB15	VSS
AB16	VCCCORE
AB17	VSS
AB18	VCCCORE
AB19	VSS
AB20	VCCCORE

Table 26. Signal List by Ball Number

No.	Signal Name
AB21	VSS
AB22	VCCCORE
AB23	VSS
AB24	D61#
AB25	D56#
AB26	VREF
AC1	BCLK
AC2	VID1
AC3	A20M#
AC4	VTT
AC5	VCCCORE
AC6	VSS
AC7	VCCCORE
AC8	VSS
AC9	VCCCORE
AC10	VSS
AC11	VCCCORE
AC12	VSS
AC13	VCCCORE
AC14	VSS
AC15	VCCCORE
AC16	VSS
AC17	VCCCORE
AC18	VSS
AC19	VCCCORE
AC20	VSS
AC21	VCCCORE
AC22	VSS
AC23	VTT
AC24	DEP3#
AC25	VSS
AC26	DEP6#
AD1	BCLK#/ CLKREF
AD2	VSS
AD3	SM#
AD4	NC
AD5	VCMOS_REF
AD6	VTT
AD7	TDI
AD8	VTT

Table 26. Signal List by Ball Number

No.	Signal Name
AD9	IGNNE#
AD10	TCK
AD11	TDO
AD12	VTT
AD13	NC
AD14	VTT
AD15	LINT0
AD16	NCHCTRL
AD17	PICD1
AD18	VTT
AD19	PICD0
AD20	VTT
AD21	BPM1#
AD22	BPM0#
AD23	NC
AD24	DEP7#
AD25	DEP1#
AD26	DEP5#
AE1	VSS
AE2	VID2
AE3	VTT
AE4	STPCLK#
AE5	VSS
AE6	INIT#
AE7	VSS
AE8	NC
AE9	VSS
AE10	THERMTRIP#
AE11	VSS
AE12	BSEL0
AE13	VSS
AE14	LINT1
AE15	VSS
AE16	RTTCTRL
AE17	VSS
AE18	VTT
AE19	VSS
AE20	BP3#
AE21	VSS
AE22	PRDY#
AE23	VSS

Table 26. Signal List by Ball Number

No.	Signal Name
AE24	DEP0#
AE25	DEP2#
AE26	VSS
AF1	VTT
AF2	VTT
AF3	VID3
AF4	IERR#
AF5	FLUSH#
AF6	FERR#
AF7	TMS
AF8	SLP#
AF9	VREF
AF10	BSEL1
AF11	TESTHI
AF12	VCMOS_REF
AF13	THERMDP
AF14	THERMDN
AF15	TRST#
AF16	SLEWCTRL
AF17	NC
AF18	NC
AF19	PREQ#
AF20	PICCLK
AF21	VREF
AF22	BP2#
AF23	BINIT#
AF24	DEP4#
AF25	VSS
AF26	VSS

Table 27. Signal Listing by Signal Name

No.	Signal Name	Signal Buffer Type
K1	A3#	AGTL I/O
J1	A4#	AGTL I/O
G2	A5#	AGTL I/O
K3	A6#	AGTL I/O
J2	A7#	AGTL I/O
H3	A8#	AGTL I/O
G1	A9#	AGTL I/O
A3	A10#	AGTL I/O
J3	A11#	AGTL I/O
H1	A12#	AGTL I/O
D3	A13#	AGTL I/O
F3	A14#	AGTL I/O
G3	A15#	AGTL I/O
C2	A16#	AGTL I/O
B5	A17#	AGTL I/O
B11	A18#	AGTL I/O
C6	A19#	AGTL I/O
B9	A20#	AGTL I/O
AC3	A20M#	1.5 V CMOS Input
B7	A21#	AGTL I/O
C8	A22#	AGTL I/O
A8	A23#	AGTL I/O
A10	A24#	AGTL I/O
B3	A25#	AGTL I/O
A13	A26#	AGTL I/O
A9	A27#	AGTL I/O
C3	A28#	AGTL I/O
C12	A29#	AGTL I/O
C10	A30#	AGTL I/O
A6	A31#	AGTL I/O
A15	A32#	AGTL I/O
A14	A33#	AGTL I/O
B13	A34#	AGTL I/O
A12	A35#	AGTL I/O
AA3	ADS#	AGTL I/O
W2	AERR#	AGTL I/O
AB3	AP0#	AGTL I/O
P3	AP1#	AGTL I/O
AC1	BCLK	Clock Input
AD1	BCLK#/CLKREF	Clock Input
C14	BERR#	AGTL I/O
AF23	BINIT#	AGTL I/O
L2	BNR#	AGTL I/O
AF22	BP2#	AGTL I/O
AE20	BP3#	AGTL I/O
AD22	BPM0#	AGTL I/O
AD21	BPM1#	AGTL I/O
R2	BPRI#	AGTL Input

Table 27. Signal Listing by Signal Name

No.	Signal Name	Signal Buffer Type
A7	BR0#	AGTL I/O
C4	BR1#	AGTL I/O
AE12	BSEL0	3.3 V CMOS Output
AF10	BSEL1	3.3 V CMOS Output
A16	D0#	AGTL I/O
B17	D1#	AGTL I/O
A17	D2#	AGTL I/O
D23	D3#	AGTL I/O
B19	D4#	AGTL I/O
C20	D5#	AGTL I/O
C16	D6#	AGTL I/O
A20	D7#	AGTL I/O
A22	D8#	AGTL I/O
A19	D9#	AGTL I/O
A23	D10#	AGTL I/O
A24	D11#	AGTL I/O
C18	D12#	AGTL I/O
D24	D13#	AGTL I/O
B24	D14#	AGTL I/O
A18	D15#	AGTL I/O
E23	D16#	AGTL I/O
B21	D17#	AGTL I/O
B23	D18#	AGTL I/O
E26	D19#	AGTL I/O
C24	D20#	AGTL I/O
F24	D21#	AGTL I/O
D25	D22#	AGTL I/O
E24	D23#	AGTL I/O
B25	D24#	AGTL I/O
G24	D25#	AGTL I/O
H24	D26#	AGTL I/O
F26	D27#	AGTL I/O
L24	D28#	AGTL I/O
H25	D29#	AGTL I/O
C26	D30#	AGTL I/O
K24	D31#	AGTL I/O
G26	D32#	AGTL I/O
K25	D33#	AGTL I/O
J24	D34#	AGTL I/O
K26	D35#	AGTL I/O
F25	D36#	AGTL I/O
N26	D37#	AGTL I/O
J26	D38#	AGTL I/O
M24	D39#	AGTL I/O
U26	D40#	AGTL I/O
P25	D41#	AGTL I/O
L26	D42#	AGTL I/O
R24	D43#	AGTL I/O

Table 27. Signal Listing by Signal Name

No.	Signal Name	Signal Buffer Type
R26	D44#	AGTL I/O
M25	D45#	AGTL I/O
V25	D46#	AGTL I/O
T24	D47#	AGTL I/O
M26	D48#	AGTL I/O
P24	D49#	AGTL I/O
AA26	D50#	AGTL I/O
T26	D51#	AGTL I/O
U24	D52#	AGTL I/O
Y25	D53#	AGTL I/O
W26	D54#	AGTL I/O
V26	D55#	AGTL I/O
AB25	D56#	AGTL I/O
T25	D57#	AGTL I/O
Y24	D58#	AGTL I/O
W24	D59#	AGTL I/O
Y26	D60#	AGTL I/O
AB24	D61#	AGTL I/O
AA24	D62#	AGTL I/O
V24	D63#	AGTL I/O
W3	DBSY#	AGTL I/O
T3	DEFER#	AGTL Input
AE24	DEP0#	AGTL I/O
AD25	DEP1#	AGTL I/O
AE25	DEP2#	AGTL I/O
AC24	DEP3#	AGTL I/O
AF24	DEP4#	AGTL I/O
AD26	DEP5#	AGTL I/O
AC26	DEP6#	AGTL I/O
AD24	DEP7#	AGTL I/O
Y1	DRDY#	AGTL I/O
AF6	FERR#	1.5 V Open Drain Output
AF5	FLUSH#	1.5 V CMOS Input
AA2	HIT#	AGTL I/O
U2	HITM#	AGTL I/O
AF4	IERR#	1.5 V Open Drain Output
AD9	IGNNE#	1.5 V CMOS Input
AE6	INIT#	1.5 V CMOS Input
AD15	INTR/LINT0	1.5 V CMOS Input
V3	LOCK#	AGTL I/O
AD16	NCHCTRL	AGTL impedance control
AE14	NMI/LINT1	1.5 V CMOS Input
AF20	PICCLK	1.8 V APIC Clock Input
AD19	PICD0	1.5 V Open Drain I/O
AD17	PICD1	1.5 V Open Drain I/O
N3	PLL1	PLL Analog Voltage
N2	PLL2	PLL Analog Voltage
AE22	PRDY#	AGTL Output

Table 27. Signal Listing by Signal Name

No.	Signal Name	Signal Buffer Type
AF19	PREQ#	1.5 V CMOS Input
AB4	PWRGOOD	1.8 V CMOS Input
R1	REQ0#	AGTL I/O
L3	REQ1#	AGTL I/O
T1	REQ2#	AGTL I/O
U1	REQ3#	AGTL I/O
L1	REQ4#	AGTL I/O
B15	RESET#	AGTL Input
T4	RP#	AGTL I/O
Y3	RS0#	AGTL I/O
V1	RS1#	AGTL I/O
U3	RS2#	AGTL I/O
M5	RSP#	AGTL Input
AE16	RTTCTRL	AGTL Pull-up Control
AF16	SLEWCTRL	AGTL Control
AF8	SLP#	1.5 V CMOS Input
AD3	SMI#	1.5 V CMOS Input
AE4	STPCLK#	1.5 V CMOS Input
AD10	TCK	1.5 V JTAG Clock Input
AD7	TDI	JTAG Input
AD11	TDO	JTAG Output
E2	TESTHI	Test Use Only
AF11	TESTHI	Test Use Only
M1	TESTLO	Test Use Only
Y4	TESTLO	Test Use Only
AF14	THERMDN	Thermal Diode Cathode
AF13	THERMDP	Thermal Diode Anode
AE10	THERMTRIP#	1.5 V Open Drain Output
AF7	TMS	JTAG Input
W1	TRDY#	AGTL I/O
AF15	TRST#	JTAG Input
AD5	VCMOS_REF	CMOS Reference Voltage
AF12	VCMOS_REF	CMOS Reference Voltage
AB1	VID0	Voltage Identification
AC2	VID1	Voltage Identification
AE2	VID2	Voltage Identification
R3	VID25mV	Voltage Identification
AF3	VID3	Voltage Identification
A4	VREF	AGTL Reference Voltage
A21	VREF	AGTL Reference Voltage
N1	VREF	AGTL Reference Voltage
AF9	VREF	AGTL Reference Voltage
AF21	VREF	AGTL Reference Voltage
AA1	VREF	AGTL Reference Voltage
AB26	VREF	AGTL Reference Voltage
H26	VREF	AGTL Reference Voltage
E3	VTT_PWRGD	VTT power good signal

Table 28. Voltage and No-Connect Ball Locations

Signal Name	Ball Numbers
NC	A2, A5, A11, B1, C1, C22, D1, D26, E1, F1, L5, N4, N24, P1, P4, P5, P26, AD4, AD13, AD23, AE8, AF17, AF18
VCCCORE	D6, D8, D10, D12, D14, D16, D18, D20, D22, E5, E7, E9, E11, E13, E15, E17, E19, E21, F6, F8, F10, F12, F14, F16, F18, F20, F22, G5, G21, H6, H22, J5, J21, K6, K22, L21, M6, M22, N5, N21, P6, P22, R5, R21, T6, T22, U5, U21, V6, V22, W5, W21, Y6, Y22, AA5, AA7, AA9, AA11, AA13, AA15, AA17, AA19, AA21, AB6, AB8, AB10, AB12, AB14, AB16, AB18, AB20, AB22, AC5, AC7, AC9, AC11, AC13, AC15, AC17, AC19, AC21
VTT	A26, C5, C7, C9, C11, C13, C15, C17, C19, C21, D5, E4, E6, G4, G23, J4, J23, L4, L23, N23, R23, U23, V4, W23, AA4, AA23, AC4, AC23, AD6, AD8, AD12, AD14, AD18, AD20, AE3, AE18, AF1, AF2
VSS	A25, B2, B4, B6, B8, B10, B12, B14, B16, B18, B20, B22, B26, C23, C25, D2, D4, D7, D9, D11, D13, D15, D17, D19, D21, E8, E10, E12, E14, E16, E18, E20, E22, E25, F2, F4, F5, F7, F9, F11, F13, F15, F17, F19, F21, F23, G6, G22, G25, H2, H4, H5, H21, H23, J6, J22, J25, K2, K4, K5, K21, K23, L6, L22, L25, M2, M3, M4, M21, M23, N6, N22, N25, P2, P21, P23, R4, R6, R22, R25, T2, T5, T21, T23, U4, U6, U22, U25, V2, V5, V21, V23, W4, W6, W22, W25, Y2, Y5, Y21, Y23, AA6, AA8, AA10, AA12, AA14, AA16, AA18, AA20, AA22, AA25, AB2, AB5, AB7, AB9, AB11, AB13, AB15, AB17, AB19, AB21, AB23, AC6, AC8, AC10, AC12, AC14, AC16, AC18, AC20, AC22, AC25, AD2, AE1, AE5, AE7, AE9, AE11, AE13, AE15, AE17, AE19, AE21, AE23, AE26, AF25, AF26

6.0 Thermal Specifications and Design Considerations

This section provides needed data for designing a thermal solution. The LV Intel Pentium III processor 512K uses micro flip-chip ball-grid-array packaging technology and has a *junction* temperature (T_J) specified at 100° C.

6.1 Thermal Specifications

Table 29 provides the thermal design power dissipation and maximum temperatures for the LV Intel Pentium III processor 512K. Systems should design for the highest possible processor power, even if a processor with a lower thermal dissipation is planned. A thermal solution should be designed to ensure the junction temperature never exceeds these specifications.

Table 29. LV Intel Pentium III Processor 512K Thermal Design Power

Processor Core Frequency (MHz)	Processor Core Voltage (V)	Processor Signature	L2 Cache Size (Kbytes)	Thermal Design Power ^{1, 2} (Max, in W)	Maximum T_J (°C)
800	1.15	06B2 06B4	512	10.63	100
933	1.15	06B4	512	11.61	100
1000	1.15	06B4	512	12.1	100

NOTES:

1. These values are specified at nominal $V_{CC_{CORE}}$ for the processor balls.
2. Processor power includes the power dissipated by the processor core, the L2 cache, and the AGTL bus termination. The maximum power for each of these components does not occur simultaneously.

6.1.1 THERMTRIP# Requirement

In the event the processor drives the THERMTRIP# signal active during valid operation, both the $V_{CC_{CORE}}$ and V_{TT} supplies to the processor must be turned off to prevent thermal runaway of the processor. Valid operation refers to the operating conditions where the THERMTRIP# signal is guaranteed valid. The time required from THERMTRIP# asserted to $V_{CC_{CORE}}$ rail at 1/2 nominal is 5 seconds and THERMTRIP# asserted to V_{TT} rail at 1/2 nominal is 5 seconds.

Table 30. THERMTRIP# Time Requirement

Power Rail	Power Target	Time required for power drop
$V_{CC_{CORE}}$	1/2 Nominal $V_{CC_{CORE}}$	5 seconds
V_{TT}	1/2 Nominal V_{TT}	5 seconds

NOTE: Once $V_{CC_{CORE}}$ and V_{TT} supplies are turned off the THERMTRIP# signal will be deactivated. System logic should ensure no “unsafe” power cycling occurs due to this deassertion.

6.1.2 Thermal Diode

The LV Intel Pentium III processor 512K has an on-die thermal diode that can be used to monitor the die temperature (T_j). A thermal sensor located on the motherboard, or a stand-alone measurement kit, may monitor the die temperature of the processor for thermal management or instrumentation purposes. Table 31 and Table 32 provide the diode interface and specifications.

Note: The reading of the thermal sensor connected to the thermal diode will not necessarily reflect the temperature of the hottest location on the die. This is due to inaccuracies in the thermal sensor, on-die temperature gradients between the location of the thermal diode and the hottest location on the die, and time based variations in the die temperature measurement. Time based variations can occur when the sampling rate of the thermal diode (by the thermal sensor) is slower than the rate at which the T_j temperature can change.

Table 31. Thermal Diode Interface

Ball Name	Ball Number	Description
THERMDP	AF13	Thermal diode anode
THERMDN	AF14	Thermal diode cathode

Table 32. Thermal Diode Parameters

Symbol	Parameter ¹	Min	Typ	Max	Unit	Notes
n	Diode Ideality Factor (5-150 μ A)	1.0011	1.0067	1.0122		1, 2, 3, 4, 6
n	Diode Ideality Factor (5-300 μ A)	1.0003	1.0091	1.0178		1, 2, 3, 5, 6

NOTES:

- Intel does not support or recommend operation of the thermal diode under reverse bias. Intel does not support or recommend operation of the thermal diode when the processor power supplies are not within their specified tolerance range.
- Characterized at 100° C
- Not 100% tested. Specified by design/characterization.
- Specified for forward bias current = 5 μ A (min) and 150 μ A (max)
- Specified for forward bias current = 5 μ A (min) and 300 μ A (max)
- The ideality factor, n, represents the deviation from ideal diode behavior as exemplified by the diode equation:

$$I_{FW} = I_S \cdot \left(e^{\frac{qV_D}{nkT}} - 1 \right)$$

where I_S = saturation current, q = electronic charge, V_D = voltage across the diode, k = Boltzmann Constant, and T = absolute temperature (Kelvin).

7.0 Processor Interface

7.1 Alphabetical Signals Reference

Table 33. Signal Description (Sheet 1 of 8)

Name	Type	Description
A20M#	I	<p>If the A20M# (Address-20 Mask) input signal is asserted, the processor masks physical address bit 20 (A20#) before looking up a line in any internal cache and before driving a read/write transaction on the bus. Asserting A20M# emulates the 8086 processor's address wrap-around at the 1 MB boundary. Assertion of A20M# is only supported in real mode.</p> <p>A20M# is an asynchronous signal. However, to ensure recognition of this signal following an I/O write instruction, it must be valid along with the TRDY# assertion of the corresponding I/O Write bus transaction.</p>
A[35:3]#	I/O	<p>The A[35:3]# (Address) signals define a 2³⁶-byte physical memory address space. When ADS# is active, these balls transmit the address of a transaction; when ADS# is inactive, these balls transmit transaction type information. These signals must connect the appropriate balls of all agents on the processor system bus. The A[35:24]# signals are parity-protected by the AP1# parity signal, and the A[23:3]# signals are parity-protected by the AP0# parity signal.</p> <p>On the active-to-inactive transition of RESET#, the processors sample the A[35:3]# balls to determine their power-on configuration. See the <i>P6 Family of Processors Hardware Developer's Manual</i> for details.</p>
ADS#	I/O	<p>The ADS# (Address Strobe) signal is asserted to indicate the validity of the transaction address on the A[35:3]# balls. All bus agents observe the ADS# activation to begin parity checking, protocol checking, address decode, internal snoop, or deferred reply ID match operations associated with the new transaction. This signal must connect the appropriate balls on all processor system bus agents.</p>
AERR#	I/O	<p>The AERR# (Address Parity Error) signal is observed and driven by all processor system bus agents, and if used, must connect the appropriate balls on all processor system bus agents. AERR# observation is optionally enabled during power-on configuration; if enabled, a valid assertion of AERR# aborts the current transaction. If AERR# observation is disabled during power-on configuration, a central agent may handle an assertion of AERR# as appropriate to the error handling architecture of the system.</p>
AP[1:0]#	I/O	<p>The AP[1:0]# (Address Parity) signals are driven by the request initiator along with ADS#, A[35:3]#, REQ[4:0]#, and RP#. AP1# covers A[35:24]#, and AP0# covers A[23:3]#. A correct parity signal is high if an even number of covered signals are low and low if an odd number of covered signals are low. This allows parity to be high when all the covered signals are high. AP[1:0]# should connect the appropriate balls of all processor system bus agents.</p>
BCLK/BCLK#	I	<p>The BCLK (Bus Clock) and BCLK# (for differential clock) signals determines the bus frequency. All processor system bus agents must receive this signal to drive their outputs and latch their inputs on the rising edge of BCLK. For differential clocking, all processor system bus agents must receive this signal to drive their outputs and latch their inputs on the BCLK and BCLK# crossing point.</p> <p>All external timing parameters are specified with respect to the BCLK signal.</p>

Table 33. Signal Description (Sheet 2 of 8)

Name	Type	Description
BERR#	I/O	<p>The BERR# (Bus Error) signal is asserted to indicate an unrecoverable error without a bus protocol violation. It may be driven by all processor system bus agents, and must connect the appropriate balls of all such agents, if used. However, the LV Intel Pentium III processor 512K does not observe assertions of the BERR# signal.</p> <p>BERR# assertion conditions are configurable at a system level. Assertion options are defined by the following options:</p> <ul style="list-style-type: none"> • Enabled or disabled. • Asserted optionally for internal errors along with IERR#. • Asserted optionally by the request initiator of a bus transaction after it observes an error. • Asserted by any bus agent when it observes an error in a bus transaction.
BINIT#	I/O	<p>The BINIT# (Bus Initialization) signal may be observed and driven by all processor system bus agents. When used, it must connect the appropriate balls of all such agents. If the BINIT# driver is enabled during power on configuration, BINIT# is asserted to signal any bus condition that prevents reliable future information.</p> <p>If BINIT# observation is enabled during power-on configuration, and BINIT# is sampled asserted, all bus state machines are reset and any data that is in transit is lost. All agents reset their rotating ID for bus arbitration to the state after Reset, and internal count information is lost. The L1 and L2 caches are not affected.</p> <p>If BINIT# observation is disabled during power-on configuration, a central agent may handle an assertion of BINIT# as appropriate to the error handling architecture of the system.</p>
BNR#	I/O	<p>The BNR# (Block Next Request) signal is used to assert a bus stall by any bus agent who is unable to accept new bus transactions. During a bus stall, the current bus owner cannot issue any new transactions.</p> <p>Since multiple agents might need to request a bus stall at the same time, BNR# is a wire-OR signal that must connect the appropriate balls of all processor system bus agents. In order to avoid wire-OR glitches associated with simultaneous edge transitions driven by multiple drivers, BNR# is activated on specific clock edges and sampled on specific clock edges.</p>
BP[3:2]#	I/O	<p>The BP[3:2]# (Breakpoint) signals are outputs from the processor that indicate the status of breakpoints.</p>
BPM[1:0]#	I/O	<p>The BPM[1:0]# (Breakpoint Monitor) signals are breakpoint and performance monitor signals. They are outputs from the processor that indicate the status of breakpoints and programmable counters used for monitoring processor performance.</p>
BPRI#	I	<p>The BPRI# (Bus Priority Request) signal is used to arbitrate for ownership of the processor system bus. It must connect the appropriate balls of all processor system bus agents. Observing BPRI# active (as asserted by the priority agent) causes all other agents to stop issuing new requests, unless such requests are part of an ongoing locked operation. The priority agent keeps BPRI# asserted until all of its requests are completed. It then releases the bus by deasserting BPRI#.</p>

Table 33. Signal Description (Sheet 3 of 8)

Name	Type	Description															
BR0# BR1#	I/O I	<p>The BR0# and BR1#(Bus Request) balls drive the BREQ[1:0]# signals in the system. The BREQ[1:0]# signals are interconnected in a rotating manner to individual processor balls. The following table gives the rotating interconnect between the processor and bus signals.</p> <p>BR0# (I/O) and BR1# Signals Rotating Interconnect</p> <table border="1"> <thead> <tr> <th>Bus Signal</th> <th>Agent 0 Ball</th> <th>Agent 1 Ball</th> </tr> </thead> <tbody> <tr> <td>BREQ0#</td> <td>BR0#</td> <td>BR1#</td> </tr> <tr> <td>BREQ1#</td> <td>BR1#</td> <td>BR0#</td> </tr> </tbody> </table> <p>During power-up configuration, the central agent asserts the BR0# bus signal in the system to assign the symmetric agent ID to the processor. The processor samples its BR0# ball on the active-to-inactive transition of the RESET# to obtain its symmetric agent ID. The processor asserts the BR0# ball to request the system bus. All agents then configure their balls to match the appropriate bus signal protocol, as shown in the following table.</p> <p>BR0# (I/O) and BR1# Signals Rotating Interconnect</p> <table border="1"> <thead> <tr> <th>Ball Sampled Active in RESET#</th> <th>Agent ID</th> </tr> </thead> <tbody> <tr> <td>BR0#</td> <td>0</td> </tr> <tr> <td>BR1#</td> <td>3</td> </tr> </tbody> </table> <p>For uniprocessor designs, BR0# must be connected to a 10-56 Ω resistor to V_{SS}.</p>	Bus Signal	Agent 0 Ball	Agent 1 Ball	BREQ0#	BR0#	BR1#	BREQ1#	BR1#	BR0#	Ball Sampled Active in RESET#	Agent ID	BR0#	0	BR1#	3
Bus Signal	Agent 0 Ball	Agent 1 Ball															
BREQ0#	BR0#	BR1#															
BREQ1#	BR1#	BR0#															
Ball Sampled Active in RESET#	Agent ID																
BR0#	0																
BR1#	3																
BSEL[1:0]	O	<p>The BSEL[1:0] (Select Processor System Bus Speed) signals are used to configure the processor for the system bus frequency. The chipset and system clock generator also uses the BSEL signals. The VTT_PWRGD signal informs the processor to output the BSEL signals. During power up the BSEL signals are indeterminate for a small period of time. The chipset and clock generator should not sample the BSEL signals until the VTT_PWRGD signal is asserted. The assertion of the VTT_PWRGD signal indicates that the BSEL signals are stable and driven to a final state by the processor. Please refer to Figure 16 for the timing relationship between the BSEL and VTT_PWRGD signals.</p> <p>The following table shows the encoding scheme for BSEL[1:0]. The LV Pentium III processor 512K supports only a 133 MHz system bus frequency. If another frequency is used, the processor is not guaranteed to function properly.</p> <table border="1"> <thead> <tr> <th>BSEL[1:0]</th> <th>System Bus Frequency</th> </tr> </thead> <tbody> <tr> <td>11</td> <td>133 MHz</td> </tr> </tbody> </table>	BSEL[1:0]	System Bus Frequency	11	133 MHz											
BSEL[1:0]	System Bus Frequency																
11	133 MHz																
CLKREF	I	<p>In Single-ended clock mode the CLKREF input is a filtered 1.25V supply voltage for the processor PLL. A voltage divider and decoupling solution is provided by the motherboard. Refer to the <i>LV Intel® Pentium® III Processor 512K Dual Processor Platform Design Guide</i> for implementation details.</p> <p>When the processor operates in differential clock mode, this signal becomes BCLK#.</p>															
D[63:0]#	I/O	<p>The D[63:0]# (Data) signals are the data signals. These signals provide a 64-bit data path between the processor system bus agents, and must connect the appropriate balls on all such agents. The data driver asserts DRDY# to indicate a valid data transfer.</p>															

Table 33. Signal Description (Sheet 4 of 8)

Name	Type	Description
DBSY#	I/O	The DBSY# (Data Bus Busy) signal is asserted by the agent responsible for driving data on the processor system bus to indicate that the data bus is in use. The data bus is released after DBSY# is deasserted. This signal must connect the appropriate balls on all processor system bus agents.
DEFER#	I	The DEFER# signal is asserted by an agent to indicate that a transaction cannot be guaranteed in-order completion. Assertion of DEFER# is normally the responsibility of the addressed memory or I/O agent. This signal must connect the appropriate balls of all processor system bus agents.
DEP[7:0]#	I/O	The DEP[7:0]# (Data Bus ECC Protection) signals provide optional ECC protection for the data bus. They are driven by the agent responsible for driving D[63:0]#, and must connect the appropriate balls of all processor system bus agents that use them. The DEP[7:0]# signals are enabled or disabled for ECC protection during power on configuration.
DRDY#	I/O	The DRDY# (Data Ready) signal is asserted by the data driver on each data transfer, indicating valid data on the data bus. In a multi-cycle data transfer, DRDY# may be deasserted to insert idle clocks. This signal must connect the appropriate balls of all processor system bus agents.
FERR#	O	The FERR# (Floating-point Error) signal is asserted when the processor detects an unmasked floating-point error. FERR# is similar to the ERROR# signal on the Intel 387 coprocessor, and is included for compatibility with systems that use MS-DOS [®] -type floating-point error reporting.
FLUSH#	I	<p>When the FLUSH# input signal is asserted, processors write back all data in the Modified state from their internal caches and invalidate all internal cache lines. At the completion of this operation, the processor issues a Flush Acknowledge transaction. The processor does not cache any new data while the FLUSH# signal remains asserted.</p> <p>FLUSH# is an asynchronous signal. However, to ensure recognition of this signal following an I/O Write instruction, it must be valid along with the TRDY# assertion of the corresponding I/O Write bus transaction.</p> <p>On the active-to-inactive transition of RESET#, each processor samples FLUSH# to determine its power-on configuration. See the <i>P6 Family of Processors Hardware Developer's Manual</i> for details.</p> <p>This signal must be connected to a 150 Ω resistor to VCC_{CMOS1.5}. Refer to the <i>LV Intel® Pentium® III Processor 512K Dual Processor Platform Design Guide</i> for implementation details and resistor tolerance.</p>
HIT# HITM#	I/O I/O	The HIT# (Snoop Hit) and HITM# (Hit Modified) signals convey transaction snoop operation results, and must connect the appropriate balls of all processor system bus agents. Any such agent may assert both HIT# and HITM# together to indicate that it requires a snoop stall; it can be continued by reasserting HIT# and HITM# together.
IERR#	O	The IERR# (Internal Error) signal is asserted by a processor as the result of an internal error. Assertion of IERR# is usually accompanied by a SHUTDOWN transaction on the processor system bus. This transaction may be converted to an external error signal (e.g., NMI) by system core logic. The processor keeps IERR# asserted until the assertion of RESET#, BINIT#, or INIT#.
IGNNE#	I	<p>The IGNNE# (Ignore Numeric Error) signal is asserted to force the processor to ignore a numeric error and to continue to execute non-control floating-point instructions. If IGNNE# is deasserted, the processor generates an exception on a non-control floating-point instruction if a previous floating-point instruction caused an error. IGNNE# has no effect when the NE bit in control register 0 is set.</p> <p>IGNNE# is an asynchronous signal. However, to ensure recognition of this signal following an I/O Write instruction, it must be valid along with the TRDY# assertion of the corresponding I/O Write bus transaction.</p>

Table 33. Signal Description (Sheet 5 of 8)

Name	Type	Description
INIT#	I	<p>The INIT# (Initialization) signal, when asserted, resets integer registers inside all processors without affecting their internal (L1 or L2) caches or floating-point registers. Each processor then begins execution at the power-on Reset vector that is configured during power-on configuration. The processor continues to handle snoop requests during INIT# assertion. INIT# is an asynchronous signal and must connect the appropriate balls of all processor system bus agents.</p> <p>When INIT# is sampled active on the active to inactive transition of RESET#, the processor executes its Built-in Self-Test (BIST).</p>
LINT0/INTR LINT1/NMI	I	<p>The LINT[1:0] (Local APIC Interrupt) signals must connect the appropriate balls of all APIC Bus agents, including all processors and the core logic or I/O APIC component. When the APIC is disabled, the LINT0 signal becomes INTR, a maskable interrupt request signal, and LINT1 becomes NMI, a non-maskable interrupt. INTR and NMI are backward compatible with the signals of those names on the Intel® Pentium® processor. Both signals are asynchronous.</p> <p>Both of these signals must be software configured via BIOS programming of the APIC register space that is to be used either as NMI/INTR or LINT[1:0]. Because the APIC is enabled by default after Reset, operation of these balls as LINT[1:0] is the default configuration.</p>
LOCK#	I/O	<p>The LOCK# signal indicates to the system that a transaction must occur atomically. This signal must connect the appropriate balls of all processor system bus agents. For a locked sequence of transactions, LOCK# is asserted from the beginning of the first transaction end of the last transaction.</p> <p>When the priority agent asserts BPRI# to arbitrate for ownership of the processor system bus, it will wait until it observes LOCK# deasserted. This enables symmetric agents to retain ownership of the processor system bus throughout the bus-locked operation and ensure the atomicity of lock.</p>
NCHCTRL	I	<p>The NCHCTRL input signal provides AGTL pull-down strength control. The LV Intel Pentium III processor 512K samples this input to determine the N-channel device strength for pull-down when it is the driving agent. This signal must be connected to a 14 Ω resistor to V_{TT}. Refer to the <i>LV Intel® Pentium® III Processor 512K Dual Processor Platform Design Guide</i> for implementation details.</p>
PICCLK	I	<p>The PICCLK (APIC Clock) signal is an input clock to the processor and core logic or I/O APIC that is required for operation of all processors, core logic, and I/O APIC components on the APIC bus.</p>
PICD[1:0]	I/O	<p>The PICD[1:0] (APIC Data) signals are used for bidirectional serial message passing on the APIC bus. PICD[1:0] must connect the appropriate balls of all processors and core logic or I/O APIC components on the APIC bus.</p>
PLL1, PLL2	I	<p>The LV Intel Pentium III processor 512K has an internal analog PLL clock generator that requires a quiet power supply. PLL1 and PLL2 are inputs to this PLL and must be connected to V_{TT} through a low pass filter that minimizes jitter. Refer to the <i>LV Intel® Pentium® III Processor 512K Dual Processor Platform Design Guide</i> for implementation details.</p>
PRDY#	O	<p>The PRDY (Probe Ready) signal is a processor output used by debug tools to determine processor debug readiness.</p>
PREQ#	I	<p>The PREQ# (Probe Request) signal is used by debug tools to request debug operation of the processors.</p>

Table 33. Signal Description (Sheet 6 of 8)

Name	Type	Description
PWRGOOD	I	<p>The PWRGOOD (Power Good) signal is processor input. The processor requires this signal to be a clean indication that the clocks and power supplies ($V_{CC_{CORE}}$, etc.) are stable and within their specifications. Clean implies that the signal will remain low (capable of sinking leakage current), without glitches, from the time the power supplies are turned on until they come within specification. The signal must then transition monotonically to a high state. PWRGOOD can be driven inactive at any time, but clocks and power must again be stable before a subsequent rising edge of PWRGOOD. It must also meet the minimum pulse width specification in Table 16, and be followed by a 1 ms RESET# pulse.</p> <p>The PWRGOOD signal must be supplied to the processor; it is used to protect internal circuits against voltage sequencing issues. It should be driven high throughout boundary scan operation.</p>
REQ[4:0]#	I/O	<p>The REQ[4:0]# (Request Command) signals must connect the appropriate balls of all processor system bus agents. They are asserted by the current bus owner over two clock cycles to define the currently active transaction type.</p>
RESET#	I	<p>Asserting the RESET# signal resets all processors to known states and invalidates their L1 and L2 caches without writing back any of their contents. For a power-on Reset, RESET# must stay active for at least one millisecond after $V_{CC_{CORE}}$ and CLK have reached their proper specifications. Upon observing active RESET#, all processor system bus agents will deassert their outputs within two clocks.</p> <p>A number of bus signals are sampled at the active-to-inactive transition of RESET# for power-on configuration. These configuration options are described in the <i>P6 Family of Processors Hardware Developer's Manual</i> for details.</p> <p>The processor may have its outputs tri-stated via power-on configuration. Otherwise, if INIT# is sampled active during the active-to-inactive transition of RESET#, the processor will execute its Built-in Self-Test (BIST). Whether or not BIST is executed, the processor will begin program execution at the power on Reset vector (default 0_FFFF_FFF0h). RESET# must connect the appropriate balls of all processor system bus agents.</p> <p>RESET# is the only AGTL signal that does not have on-die termination. Therefore, it is necessary to place a discrete 56 Ω resistor to V_{TT}. Refer to the <i>LV Intel® Pentium® III Processor 512K Dual Processor Platform Design Guide</i> for implementation details.</p>
RP#	I/O	<p>The RP# (Request Parity) signal is driven by the request initiator, and provides parity protection on ADS# and REQ[4:0]#. It must connect the appropriate balls of all processor system bus agents.</p> <p>A correct parity signal is high if an even number of covered signals are low and low if an odd number of covered signals are low. This definition allows parity to be high when all covered signals are high.</p>
RS[2:0]#	I/O	<p>The RS[2:0]# (Response Status) signals are driven by the response agent (the agent responsible for completion of the current transaction), and must connect the appropriate balls of all processor system bus agents.</p>
RSP#	I	<p>The RSP# (Response Parity) signal is driven by the response agent (the agent responsible for completion of the current transaction) during assertion of RS[2:0]#, the signals for which RSP# provides parity protection. It must connect the appropriate balls of all processor system bus agents.</p> <p>A correct parity signal is high if an even number of covered signals are low and low if an odd number of covered signals are low. When RS[2:0]# = 000, RSP# is also high, since this indicates it is not being driven by an agent that can guarantee correct parity.</p>
RTTCTRL	I	<p>The RTTCTRL input signal provides AGTL termination control. The LV Intel Pentium III processor 512K samples this input to set the termination resistance value for the on-die AGTL termination. This signal must be connected to a 56 Ω resistor to V_{SS} on a uniprocessor platform or a 68 Ω resistor to V_{SS} on a dual-processor platform. Refer to the <i>LV Intel® Pentium® III Processor 512K Dual Processor Platform Design Guide</i> for implementation details.</p>

Table 33. Signal Description (Sheet 7 of 8)

Name	Type	Description
SLEWCTRL	I	The SLEWCTRL input signal provides AGTL slew rate control. The LV Intel Pentium III processor 512K samples this input to determine the slew rate for AGTL signals when it is the driving agent. This signal must be connected to a 110 Ω resistor to V _{SS} . Refer to the <i>LV Intel® Pentium® III Processor 512K Dual Processor Platform Design Guide</i> for implementation details.
SLP#	I	The SLP# (Sleep) signal, when asserted in Stop-Grant state, causes processors to enter the Sleep state. During Sleep state, the processor stops providing internal clock signals to all units, leaving only the Phase-Locked Loop (PLL) still operating. Processors in this state will not recognize snoops or interrupts. The processor will only recognize assertions of the SLP#, STPCLK#, and RESET# signals while in Sleep state. If SLP# is deasserted, the processor exits Sleep state and returns to Stop-Grant state, restarting its internal clock signals to the bus and APIC processor core units.
SMI#	I	The SMI# (System Management Interrupt) signal is asserted asynchronously by system logic. Upon accepting a System Management Interrupt, processors save the current state and enter System Management Mode (SMM). An SMI Acknowledge transaction is issued, and the processor begins program execution from the SMM handler.
STPCLK#	I	The STPCLK# (Stop Clock) signal, when asserted, causes processors to enter a low power Stop-Grant state. The processor issues a Stop-Grant Acknowledge transaction, and stops providing internal clock signals to all processor core units except the bus and APIC units. The processor continues to snoop bus transactions and latch interrupts while in Stop-Grant state. When STPCLK# is deasserted, the processor restarts its internal clock to all units, services pending interrupts while in the Stop-Grant state, and resumes execution. The assertion of STPCLK# has no effect on the bus clock; STPCLK# is an asynchronous input.
TCK	I	The TCK (Test Clock) signal provides the clock input for the processor Test Bus (also known as the Test Access Port).
TDI	I	The TDI (Test Data In) signal transfers serial test data into the processor. TDI provides the serial input that is needed for JTAG specification support.
TDO	O	The TDO (Test Data Out) signal transfers serial test data out of the processor. TDO provides the serial output that is needed for JTAG specification support.
TESTHI[2:1]	I	The TESTHI[2:1] (Test input High) signals are used during processor test and need to be individually pulled up to V _{TT} during normal operation. Refer to the <i>LV Intel® Pentium® III Processor 512K Dual Processor Platform Design Guide</i> for implementation details.
TESTLO[2:1]	I	The TESTLO[2:1] (Test input Low) signals are used during processor test and need to be pulled to ground during normal operation. Refer to the <i>LV Intel® Pentium® III Processor 512K Dual Processor Platform Design Guide</i> for implementation details.
THERMDN	O	Thermal Diode Cathode. Used to calculate core (junction) temperature. See Section 6.0 .
THERMDP	I	Thermal Diode Anode. Used to calculate core (junction) temperature. See Section 6.0 .

Table 33. Signal Description (Sheet 8 of 8)

Name	Type	Description
THERMTRIP#	O	<p>The processor protects itself from catastrophic overheating through the use of an internal thermal sensor. This sensor is set well above the normal operating temperature to ensure that there are no false trips. The processor stops all execution when the junction temperature exceeds approximately 135 °C. This is signaled to the system by the THERMTRIP# (Thermal Trip) ball. Once activated, the signal remains latched, and the processor remains stopped, until RESET# goes active or core power is removed. There is no hysteresis built into the thermal sensor itself; when the die temperature drops below the trip level, a RESET# pulse will reset the processor and execution continues. If the temperature does not drop below the trip level, the processor drives THERMTRIP# and remains stopped.</p> <p>In the event the processor drives the THERMTRIP# signal active during valid operation, both the V_{CC}CORE and V_{TT} supplies to the processor must be turned off to prevent thermal runaway of the processor. Valid operation refers to the operating conditions where the THERMTRIP# signal is guaranteed valid. The time required from THERMTRIP# asserted to V_{CC}CORE rail at 1/2 nominal is 5 seconds and THERMTRIP# asserted to V_{TT} rail at 1/2 nominal is 5 seconds. Once V_{CC}CORE and V_{TT} supplies are turned off the THERMTRIP# signal is deactivated. System logic should ensure that no “unsafe” power cycling occurs due to this deassertion.</p>
TMS	I	The TMS (Test Mode Select) signal is a JTAG specification support signal used by debug tools.
TRDY#	I/O	The TRDY# (Target Ready) signal is asserted by the target to indicate that it is ready to receive a write or implicit writeback data transfer. TRDY# must connect the appropriate balls of all processor system bus agents.
TRST#	I	The TRST# (Test Reset) signal resets the Test Access Port (TAP) logic. TRST# must be driven low during power on Reset.
V _{CMOS_REF}	I	<p>The V_{CMOS_REF} input ball supplies non-AGTL reference voltage; the voltage level should be nominally 2/3 of V_{CMOS}. V_{CMOS_REF} is used by the non-AGTL receivers to determine if a signal is a logical 0 or a logical 1.</p> <p>The Thevenin equivalent impedance of the V_{CMOS_REF} generation circuits must be less than 0.5 KΩ/1 KΩ (i.e., top resistor 500 Ω, bottom resistor 1 KΩ). Refer to the <i>LV Intel® Pentium® III Processor 512K Dual Processor Platform Design Guide</i> for implementation details.</p>
VID [3:0,25mV]	O	The VID[3:0, 25 mV] (Voltage ID) balls can be used to support automatic selection of power supply voltages. These balls are CMOS signals that must be pulled up to 3.3 V power rail with 1 KΩ resistors. The VID balls are needed to cleanly support voltage specification variations on processors. See Table 5 for definitions of these balls. The power supply must supply the voltage that is requested by these balls, or disable itself.
V _{REF}	I	The V _{REF} input balls supply the AGTL reference voltage; the voltage level is typically 2/3 of V _{TT} . V _{REF} is used by the AGTL receivers to determine if a signal is a logical 0 or a logical 1.
V _{TT_PWRGD}	I	The V _{TT_PWRGD} signal informs the system that the VID/BSEL signals are in their correct logic state. During Power-up, the VID signals will be in an indeterminate state for a small period of time. The voltage regulator or the VRM should not sample and/or latch the VID signals until the V _{TT_PWRGD} signal is asserted. The assertion of the V _{TT_PWRGD} signal indicates that the VID signals are stable and are driven to the final state by the processor. Refer to Figure 16 for the power-up timing sequence for the V _{TT_PWRGD} and the VID signals.

7.2 Signal Summaries

Table 34. Input Signals

Name	Active Level	Clock	Signal Group	Qualified
A20M#	Low	Asynch	CMOS	Always
BCLK	High	—	System Bus	Always
BCLK#	Low	—	System Bus	Always
BPRI#	Low	BCLK	System Bus	Always
DEFER#	Low	BCLK	System Bus	Always
FLUSH#	Low	Asynch	CMOS	Always
IGNNE#	Low	Asynch	CMOS	Always
INIT#	Low	Asynch	CMOS	Always
INTR	High	Asynch	CMOS	APIC disabled mode
LINT[1:0]	High	Asynch	CMOS	APIC enabled mode
NCHCTRL	N/A	Asynch	Power/Other	
NMI	High	Asynch	CMOS	APIC disabled mode
PICCLK	High	—	APIC	Always
PREQ#	Low	Asynch	CMOS	Always
PWRGOOD	High	Asynch	CMOS	Always
RESET#	Low	BCLK	System Bus	Always
RSP#	Low	BCLK	System Bus	Always
RTTCTRL	N/A	Asynch	Power/Other	
SLEWCTRL	N/A	Asynch	Power/Other	
SLP#	Low	Asynch	Implementation	
SMI#	Low	Asynch	CMOS	Always
STPCLK#	Low	Asynch	CMOS	Always
TCK	High	—	JTAG	
TDI	High	TCK	JTAG	
TMS	High	TCK	JTAG	
TRST#	Low	Asynch	JTAG	
VRI#	Low	BCLK	System Bus	Always
VTT_PWRGD	High	Asynch	Power/Other	

Table 35. Output Signals

Name	Active Level	Clock	Signal Group
BSEL[1:0]	High	Asynch	Open-Drain
FERR#	Low	Asynch	Open-Drain
IERR#	Low	Asynch	Open-Drain
PRDY#	Low	BCLK	System Bus
TDO	High	TCK	JTAG
THERMTRIP#	Low	Asynch	Open-Drain
VID[3:0, 25mV]		Asynch	Power/Other

Table 36. Input/Output Signals (Single Driver)

Name	Active Level	Clock	Signal Group	Qualified
A[35:3]#	Low	BCLK	System Bus	ADS#, ADS#+1
ADS#	Low	BCLK	System Bus	Always
AP[1:0]#	Low	BCLK	System Bus	ADS#, ADS#+1
BP[3:2]#	Low	BCLK	System Bus	Always
BPM[1:0]#	Low	BCLK	System Bus	Always
BR0#	Low	BCLK	System Bus	Always
D[63:0]#	Low	BCLK	System Bus	DRDY#
DBSY#	Low	BCLK	System Bus	Always
DEP[7:0]#	Low	BCLK	System Bus	DRDY#
DRDY#	Low	BCLK	System Bus	Always
LOCK#	Low	BCLK	System Bus	Always
REQ[4:0]#	Low	BCLK	System Bus	ADS#, ADS#+1
RP#	Low	BCLK	System Bus	ADS#, ADS#+1
RS[2:0]#	Low	BCLK	System Bus	Always
TRDY#	Low	BCLK	System Bus	Response phase

Table 37. Input/Output Signals (Multiple Driver)

Name	Active Level	Clock	Signal Group	Qualified
AERR#	Low	BCLK	System Bus	ADS#+3
BERR#	Low	BCLK	System Bus	Always
BINIT#	Low	BCLK	System Bus	Always
BNR#	Low	BCLK	System Bus	Always
HIT#	Low	BCLK	System Bus	Always
HITM#	Low	BCLK	System Bus	Always
PICD[1:0]	High	PICCLK	APIC	Always

1	Related Documents	9
2	LV/ULV Intel® Pentium® III Processor 512K CPUID	15
3	System Bus Signal Groups	16
4	BSEL[1:0] Encoding	17
5	LV Intel Pentium III Processor 512K VID Values	22
6	LV Intel Pentium III Processor 512K Absolute Maximum Ratings	24
7	Power Specifications for LV Intel Pentium III Processor 512K	25
8	V _{CC} _{CORE} Static and Transient Tolerance	27
9	AGTL Signal Group Levels Specifications	28
10	Processor AGTL Bus Specifications	28
11	CLKREF, APIC, TAP, CMOS, and Open-Drain Signal Group DC Specifications	29
12	System Bus Clock AC Specifications (Differential)	30
13	System Bus Clock AC Specifications (133 MHz, Single-Ended)	31
14	Valid LV Intel Pentium III Processor 512K Frequencies	32
15	AGTL Signal Groups AC Specifications	32
16	CMOS and Open-Drain Signal Groups AC Specifications	32
17	Reset Configuration AC Specifications and Power On Timings	33
18	APIC Bus Signal AC Specifications	33
19	TAP Signal AC Specifications	34
20	BCLK (Differential) DC Specifications and AC Signal Quality Specifications	40
21	BCLK (Single-Ended) DC Specifications and AC Signal Quality Specifications	40
22	PICCLK DC Specifications and AC Signal Quality Specifications	41
23	133 MHz AGTL Signal Group Overshoot/Undershoot Tolerance at the Processor Core	43
24	Non-AGTL Signal Group Overshoot/Undershoot Tolerance at the Processor Core	43
25	Micro-FCBGA Package Mechanical Specifications	46
26	Signal List by Ball Number	51
27	Signal Listing by Signal Name	54
28	Voltage and No-Connect Ball Locations	56
29	LV Intel Pentium III Processor 512K Thermal Design Power	57
30	THERMTRIP# Time Requirement	57
31	Thermal Diode Interface	58
32	Thermal Diode Parameters	58
33	Signal Description	59
34	Input Signals	67
35	Output Signals	68
36	Input/Output Signals (Single Driver)	68
37	Input/Output Signals (Multiple Driver)	68



1	AGTL Bus Topology	11
2	Stop Clock State Machine	12
3	Differential/Single-Ended Clocking Example	15
4	Single Ended Clock BSEL Circuit (133 MHz)	18
5	Differential Clock BSEL Circuit	19
6	PLL Filter	21
7	V_{TT} Power Good and Bus Select Interconnect Diagram	23
8	Power Supply Current Slew Rate ($dlcc_{CORE}/dt$)	26
9	$V_{CC_{CORE}}$ Static and Transient Tolerance	27
10	BCLK (Single Ended)/PICCLK/TCK Generic Clock Timing Waveform.....	35
11	Differential BCLK/BCLK# Waveform (Common Mode)	35
12	BCLK/BCLK# Waveform (Differential Mode).....	36
13	Valid Delay Timings	36
14	Setup and Hold Timings	37
15	Cold/Warm Reset and Configuration Timings	37
16	Power-On Sequence and Reset Timings	38
17	Test Timings (Boundary Scan)	39
18	Test Reset Timings.....	39
19	BCLK (Single-Ended)/PICCLK Generic Clock Waveform	41
20	Maximum Acceptable Overshoot/Undershoot Waveform.....	42
21	Noise Estimation.....	45
22	Micro-FCBGA Package – Top and Bottom Isometric Views.....	47
23	Micro-FCBGA Package – Top and Side Views	48
24	Micro-FCBGA Package - Bottom View	49
25	Ball Map - Top View.....	50



1.0	Introduction	7
1.1	Overview.....	7
1.2	Terminology.....	8
1.3	Related Documents.....	9
2.0	Processor Features	10
2.1	512-Kbyte On-Die Integrated L2 Cache.....	10
2.2	Data Prefetch Logic.....	10
2.3	Processor System Bus and V_{REF}	10
2.4	Differential Clocking.....	11
2.5	Clock Control and Low Power States.....	11
2.5.1	Normal State—State 1.....	12
2.5.2	AutoHALT Power Down State—State 2.....	12
2.5.3	Stop-Grant State—State 3.....	13
2.5.4	HALT/Grant Snoop State—State 4.....	13
2.5.5	Sleep State—State 5.....	13
2.5.6	Clock Control.....	14
2.6	Power and Ground Balls.....	14
2.7	Processor System Bus Clock and Processor Clocking.....	14
2.8	Processor System Bus Unused Balls.....	15
2.9	LV Intel Pentium III Processor 512K CPUID.....	15
3.0	Electrical Specifications	16
3.1	Processor System Bus Signal Groups.....	16
3.1.1	Asynchronous vs. Synchronous for System Bus Signals.....	17
3.1.2	System Bus Frequency Select Signals.....	17
3.2	Single-Ended Clocking BSEL[1:0] Implementation.....	17
3.3	Differential Host Bus Clocking Routing.....	18
3.3.1	Differential Clocking BSEL[1:0] Implementation.....	18
3.4	Signal State in Low-Power States.....	19
3.4.1	System Bus Signals.....	19
3.4.2	CMOS and Open-Drain Signals.....	19
3.4.3	Other Signals.....	19
3.5	Test Access Port (TAP) Connection.....	20
3.6	Power Supply Requirements.....	20
3.6.1	Decoupling Guidelines.....	20
3.6.2	Processor VCC_{CORE} Decoupling.....	20
3.6.3	Voltage Planes.....	21
3.7	Voltage Identification.....	21
3.8	System Bus Clock and Processor Clocking.....	24
3.9	Maximum Ratings.....	24
3.10	DC Specifications.....	25
3.11	AC Specifications.....	30
3.11.1	System Bus, Clock, APIC, TAP, CMOS, and Open-Drain AC Specifications.....	30
4.0	System Signal Simulations	40
4.1	System Bus Clock (BCLK) and PICCLK DC Specifications and AC Signal Quality Specifications.....	40
4.2	AGTL AC Signal Quality Specifications.....	42
4.3	Non-AGTL Signal Quality Specifications.....	43

4.3.1	PWRGOOD Signal Quality Specification.....	44
4.3.2	VTT_PWRGD Signal Quality Specification.....	44
5.0	Mechanical Specifications.....	46
5.1	Surface Mount Micro-FCBGA Package	46
5.2	Signal Listings.....	50
6.0	Thermal Specifications and Design Considerations.....	57
6.1	Thermal Specifications	57
6.1.1	THERMTRIP# Requirement	57
6.1.2	Thermal Diode	58
7.0	Processor Interface	59
7.1	Alphabetical Signals Reference.....	59
7.2	Signal Summaries.....	67