

# 1.4 pC Charge Injection, 100 pA Leakage, Quad SPST Switches

## DESCRIPTION

The DG611E, DG612E, and DG613E contain four independently selectable SPST switches. They offer improved performance over the industry standard DG611 and DG611A series. The DG611E and DG612E have all switches normally closed and normally open respectively, while the DG613E has 2 normally open and 2 normally closed switches.

They are designed to operate from a 3 V to 16 V single supply or from  $\pm 3$  V to  $\pm 8$  V dual supplies and are fully specified at +3 V, +5 V and  $\pm 5$  V. All control logic inputs have guaranteed 2 V logic high limits when operating from +5 V or  $\pm 5$  V supplies and 1.4 V when operating from a +3 V supply.

The DG611E, DG612E, and DG613E switches conduct equally well in both directions and offer rail to rail analog signal handling.

1.4 pC low charge injection, coupled with very low switch capacitance: 3 pF, fast switching speed:  $t_{on}/t_{off}$  23 ns/14 ns and excellent 3 dB bandwidth: 1 GHz, make these products ideal for precision instrumentation, high-end data acquisition, automated test equipment and high speed communication applications.

Operation temperature is specified from  $-40$  °C to  $+125$  °C.

The DG611E, DG612E, and DG613E are available in 16 lead SOIC, TSSOP and the space saving 1.8 mm x 2.6 mm miniQFN packages.

## FEATURES

- 3 V to 16 V single supply or  $\pm 3$  V to  $\pm 8$  V dual supply
- Low charge injection (1.4 pC typ.)
- Leakage current  $< 0.25$  nA at 85 °C
- Low switch capacitance ( $C_{soff}$  3 pF typ.)
- Fully specified with single supply operation at 3 V, 5 V, and dual supplies at  $\pm 5$  V
- Low voltage, 2.5 V CMOS/TTL compatible
- 1 GHz, 3 dB bandwidth
- Excellent isolation performance (-59 dB at 10 MHz)
- Excellent crosstalk performance (-74 dB at 10 MHz)
- Fully specified from  $-40$  °C to  $+85$  °C and  $-40$  °C to  $+125$  °C
- 16 lead SOIC, TSSOP and miniQFN package (1.8 mm x 2.6 mm)
- Material categorization: for definitions of compliance please see [www.vishay.com/doc?99912](http://www.vishay.com/doc?99912)



## APPLICATIONS

- Precision instrumentation
- Medical instrumentation
- Automated test equipment
- High speed communications applications
- High-end data acquisition
- Sample and hold applications
- Sample and hold systems

## FUNCTIONAL BLOCK DIAGRAM AND PIN CONFIGURATION

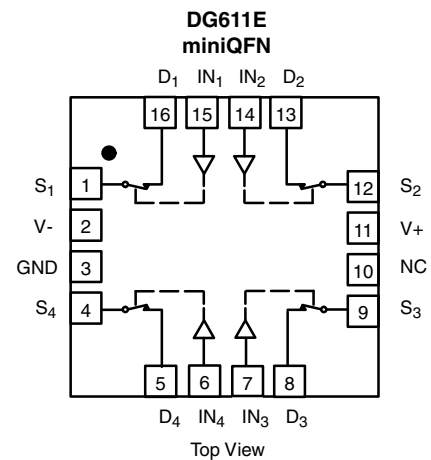
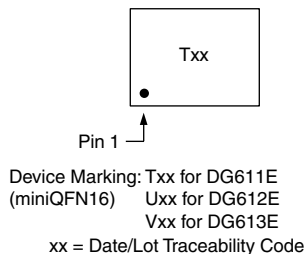
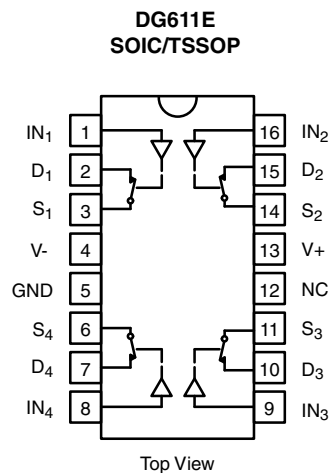

TRUTH TABLE		
LOGIC	DG611E	DG612E
0	On	Off
1	Off	On

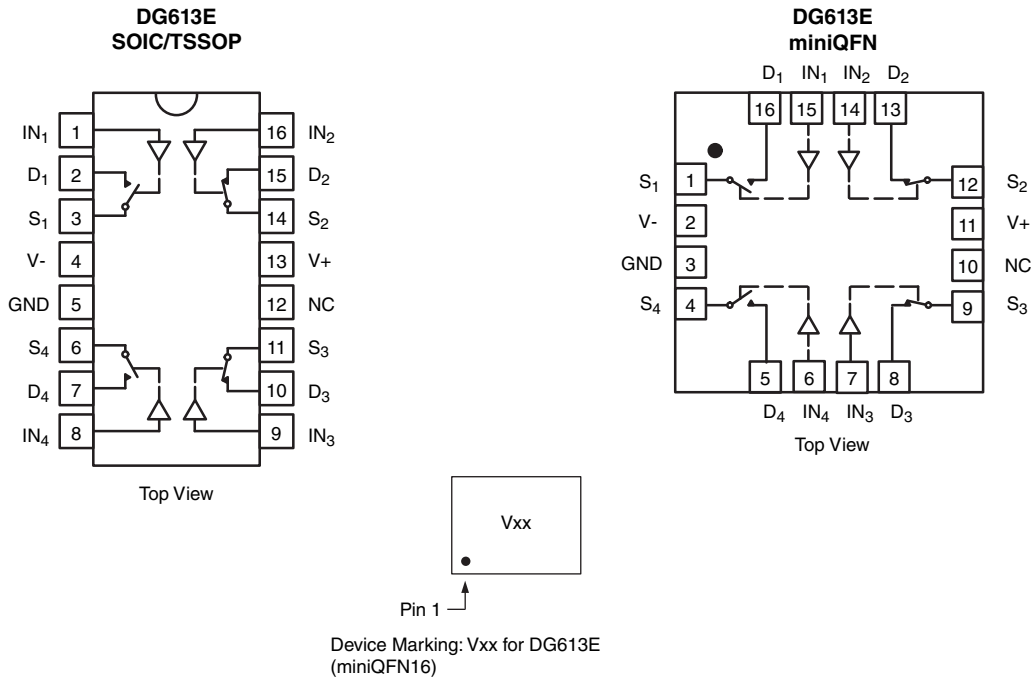
**FUNCTIONAL BLOCK DIAGRAM AND PIN CONFIGURATION**

TRUTH TABLE		
LOGIC	SW1, SW4	SW2, SW3
0	Off	On
1	On	Off

ORDERING INFORMATION		
TEMP. RANGE	PACKAGE	PART NUMBER
-40 °C to +125 °C <sup>a</sup>	16-pin TSSOP	DG611EEQ-T1-GE4
		DG612EEQ-T1-GE4
		DG613EEQ-T1-GE4
	16-pin narrow SOIC	DG611EEY-T1-GE4
		DG612EEY-T1-GE4
		DG613EEY-T1-GE4
	16-pin miniQFN	DG611EEN-T1-GE4
		DG612EEN-T1-GE4
		DG613EEN-T1-GE4

**Note**

a. -40 °C to +85 °C datasheet limits apply



<b>ABSOLUTE MAXIMUM RATINGS</b> ( $T_A = 25\text{ }^\circ\text{C}$ , unless otherwise noted)			
<b>PARAMETER</b>		<b>LIMIT</b>	<b>UNIT</b>
V+ to V-		-0.3 to +18	V
GND to V-		18	
$V_S, V_D$		(V-) - 0.3 to (V+) + 0.3 or 30 mA, whichever occurs first	
Digital inputs <sup>a</sup>		(GND) - 0.3 to 18	
Continuous current (any terminal)		30	mA
Peak current, S or D (pulsed 1 ms, 10 % duty cycle)		100	
Storage temperature		-65 to +150	$^\circ\text{C}$
Power dissipation (package) <sup>b</sup>	16-pin TSSOP <sup>c</sup>	450	mW
	16-pin miniQFN <sup>d</sup>	525	
	16-pin narrow SOIC <sup>e</sup>	640	
Thermal resistance (package) <sup>b</sup>	16-pin TSSOP	178	$^\circ\text{C}/\text{W}$
	16-pin miniQFN	152	
	16-pin narrow SOIC	125	
ESD / HBM	EIA / JESD22-A114-A	2K	V
ESD / CDM	EIA / JESD22-C101-A	1K	
Latch up	JESD78	300	mA

**Notes**

- a. Signals on SX, DX, or INX exceeding V+ or V- will be clamped by internal diodes. Limit forward diode current to maximum current ratings
- b. All leads welded or soldered to PC board
- c. Derate 5.6 mW/ $^\circ\text{C}$  above 70  $^\circ\text{C}$
- d. Derate 6.6 mW/ $^\circ\text{C}$  above 70  $^\circ\text{C}$
- e. Derate 8 mW/ $^\circ\text{C}$  above 70  $^\circ\text{C}$
- f. Manual soldering with iron is not recommended for leadless components. The miniQFN-16 is a leadless package. The end of the lead terminal is exposed copper (not plated) as a result of the singulation process in manufacturing. A solder fillet at the exposed copper lip cannot be guaranteed and is not required to ensure adequate bottom side solder interconnection



SPECIFICATIONS FOR DUAL SUPPLIES (V+ = +5 V, V- = -5 V)										
PARAMETER	SYMBOL	TEST CONDITIONS UNLESS OTHERWISE SPECIFIED V+ = +5 V, V- = -5 V VIN = 2 V, 0.8 V <sup>a</sup>	TEMP. <sup>b</sup>	LIMITS					UNIT	
				TYP. <sup>c</sup>	-40 °C to +125 °C		-40 °C to +85 °C			
					MIN. <sup>d</sup>	MAX. <sup>d</sup>	MIN. <sup>d</sup>	MAX. <sup>d</sup>		
<b>Analog Switch</b>										
Analog signal range <sup>e</sup>	V <sub>ANALOG</sub>		Full	-	-5	5	-5	5	V	
Drain-source on-resistance	R <sub>DS(on)</sub>	I <sub>S</sub> = 1 mA, V <sub>D</sub> = -3 V, 0 V, +3 V	Room	72	-	115	-	115	Ω	
			Full	-	-	160	-	140		
On-resistance match	ΔR <sub>DS(on)</sub>	I <sub>S</sub> = 1 mA, V <sub>D</sub> = ± 3 V	Room	0.6	-	2.5	-	2.5	Ω	
			Full	-	-	5	-	4.5		
On-resistance flatness	R <sub>flat(on)</sub>	I <sub>S</sub> = 1 mA, V <sub>D</sub> = -3 V, 0 V, +3 V	Room	15	-	20	-	20	Ω	
			Full	-	-	30	-	25		
Switch off leakage current	I <sub>S(off)</sub>	V+ = 5.5 V, V- = -5.5 V V <sub>D</sub> = +4.5 V / -4.5 V V <sub>S</sub> = -4.5 V / +4.5 V	Room	±0.0005	-0.1	0.1	-0.1	0.1	nA	
			Full	-	-2	2	-0.25	0.25		
	Room		±0.006	-0.1	0.1	-0.1	0.1			
	Full		-	-2	2	-0.25	0.25			
Switch on leakage current	I <sub>D(on)</sub>	V+ = 5.5 V, V- = -5.5 V V <sub>D</sub> = V <sub>S</sub> = ± 4.5 V	Room	±0.008	-0.1	0.1	-0.1	0.1	nA	
			Full	-	-6	6	-0.25	0.25		
<b>Digital Control</b>										
Input current, V <sub>IN</sub> low	I <sub>IL</sub>	V <sub>IN</sub> under test = 0.8 V	Full	0.01	-0.1	0.1	-0.1	0.1	μA	
Input current, V <sub>IN</sub> high	I <sub>IH</sub>	V <sub>IN</sub> under test = 2 V	Full	0.01	-0.1	0.1	-0.1	0.1		
Input capacitance <sup>e</sup>	C <sub>IN</sub>	f = 1 MHz	Room	3	-	-	-	-	pF	
<b>Dynamic Characteristics</b>										
Turn-on time	t <sub>ON</sub>	R <sub>L</sub> = 300 Ω, C <sub>L</sub> = 35 pF V <sub>S</sub> = ± 3 V	Room	23	-	50	-	50	ns	
			Full	-	-	75	-	60		
Turn-off time	t <sub>OFF</sub>		Room	14	-	35	-	35		
			Full	-	-	50	-	45		
Break-before-make time delay	t <sub>BBM</sub>		DG613E only, V <sub>S</sub> = 3 V R <sub>L</sub> = 300 Ω, C <sub>L</sub> = 35 pF	Room	15	-	-	-		-
				Full	-	2	-	2		-
Charge injection <sup>e</sup>	Q <sub>INJ</sub>	V <sub>g</sub> = 0 V, R <sub>g</sub> = 0 Ω, C <sub>L</sub> = 1 nF	Room	1.4	-	-	-	-	pC	
Off isolation <sup>e</sup>	OIRR	R <sub>L</sub> = 50 Ω, C <sub>L</sub> = 5 pF f = 10 MHz	Room	-59	-	-	-	-	dB	
Channel-to-channel crosstalk <sup>e</sup>	X <sub>TALK</sub>		Room	-74	-	-	-	-		
Bandwidth <sup>e</sup>	BW	R <sub>L</sub> = 50 Ω, C <sub>L</sub> = 5 pF	Room	1	-	-	-	-	GHz	
Source off capacitance <sup>e</sup>	C <sub>S(off)</sub>	f = 1 MHz; V <sub>S</sub> = 0 V	Room	3	-	-	-	-	pF	
Drain off capacitance <sup>e</sup>	C <sub>D(off)</sub>		Room	3	-	-	-	-		
Drain on capacitance <sup>e</sup>	C <sub>D(on)</sub>		f = 1 MHz; V <sub>S</sub> = V <sub>D</sub> = 0 V	Room	7	-	-	-		-
Total harmonic distortion <sup>e</sup>	THD	Signal = 1 V <sub>RMS</sub> , 20 Hz to 20 kHz, R <sub>L</sub> = 600 Ω	Room	0.13	-	-	-	-	%	
<b>Power Supplies</b>										
Power supply current	I+	V+ = +5 V, V- = -5 V V <sub>IN</sub> = 0 V or 5 V	Room	0.001	-	0.1	-	0.1	μA	
			Full	-	-	1	-	1		
Negative supply current	I-		Room	-0.001	-0.1	-	-0.1	-		
			Full	-	-1	-	-1	-		
Ground current	I <sub>GND</sub>		Room	-0.001	-0.1	-	-0.1	-		
			Full	-	-1	-	-1	-		



SPECIFICATIONS FOR SINGLE SUPPLIES (V+ = +5 V, V- = 0 V)										
PARAMETER	SYMBOL	TEST CONDITIONS UNLESS OTHERWISE SPECIFIED V+ = +5 V, V- = 0 V VIN = 2 V, 0.8 V <sup>a</sup>	TEMP. <sup>b</sup>	LIMITS					UNIT	
				TYP. <sup>c</sup>	-40 °C to +125 °C		-40 °C to +85 °C			
					MIN. <sup>d</sup>	MAX. <sup>d</sup>	MIN. <sup>d</sup>	MAX. <sup>d</sup>		
<b>Analog Switch</b>										
Analog signal range <sup>e</sup>	V <sub>ANALOG</sub>		Full	-	0	5	0	5	V	
Drain-source on-resistance	R <sub>DS(on)</sub>	V+ = 5 V, V- = 0 V IS = 1 mA, VD = +3.5 V	Room	130	-	170	-	170	Ω	
			Full	-	-	235	-	215		
On-resistance match	ΔR <sub>DS(on)</sub>	V+ = 5 V, V- = 0 V, IS = 1 mA, VD = 3.5 V	Room	0.6	-	5	-	5	Ω	
			Full	-	-	12	-	10		
On-resistance flatness	R <sub>flat(on)</sub>	V+ = 5 V, V- = 0 V, IS = 1 mA, VD = 0 V, 3.5 V	Room	29	-	50	-	50	Ω	
			Full	-	-	100	-	90		
Switch off leakage current	IS(off)	V+ = 5.5 V, V- = 0 V VD = 4.5 V / 1 V VS = 1 V / 4.5 V	Room	±0.0005	-0.1	0.1	-0.1	0.1	nA	
			Full	-	-2	2	-0.25	0.25		
	Room		±0.006	-0.1	0.1	-0.1	0.1			
	Full		-	-2	2	-0.25	0.25			
Switch on leakage current	ID(on)	V+ = 5.5 V, V- = 0 V VD = VS = 1 V / 4.5 V	Room	±0.008	-0.1	0.1	-0.1	0.1	nA	
			Full	-	-6	6	-0.25	0.25		
<b>Digital Control</b>										
Input current, VIN low	IL	VIN under test = 0.8 V	Full	0.01	-0.1	0.1	-0.1	0.1	μA	
Input current, VIN high	I <sub>H</sub>	VIN under test = 2 V	Full	0.01	-0.1	0.1	-0.1	0.1		
Input capacitance <sup>e</sup>	C <sub>IN</sub>	f = 1 MHz	Room	4	-	-	-	-	pF	
<b>Dynamic Characteristics</b>										
Turn-on time <sup>e</sup>	t <sub>ON</sub>	RL = 300 Ω, CL = 35 pF VS = 3 V	Room	33	-	60	-	60	ns	
			Full	-	-	90	-	80		
Turn-off time <sup>e</sup>	t <sub>OFF</sub>		Room	14	-	35	-	35		
			Full	-	-	45	-	40		
Break-before-make time delay <sup>e</sup>	t <sub>BBM</sub>		DG613E only, VS = 3 V RL = 300 Ω, CL = 35 pF	Room	19	-	-	-		-
				Full	-	2	-	2		-
Charge injection <sup>e</sup>	Q <sub>INJ</sub>	Vg = 0 V, Rg = 0 Ω, CL = 1 nF	Full	1.5	-	-	-	-	pC	
Off isolation <sup>e</sup>	OIRR	RL = 50 Ω, CL = 5 pF f = 10 MHz	Room	-59	-	-	-	-	dB	
Channel-to-channel crosstalk <sup>e</sup>	X <sub>TALK</sub>		Room	-70	-	-	-	-		
Bandwidth <sup>e</sup>	BW	RL = 50 Ω, CL = 5 pF	Room	880	-	-	-	-	MHz	
Source off capacitance <sup>e</sup>	CS(off)	f = 1 MHz; VS = 0 V	Room	3	-	-	-	-	pF	
Drain off capacitance <sup>e</sup>	CD(off)		Room	3	-	-	-	-		
Drain on capacitance <sup>e</sup>	CD(on)	f = 1 MHz; VS = VD = 0 V	Room	7	-	-	-	-	pF	
<b>Power Supplies</b>										
Power supply current	I+	VIN = 0 V or 5 V	Room	0.001	-	0.1	-	0.1	μA	
			Full	-	-	1	-	1		
Negative supply current	I-		Room	-0.001	-0.1	-	-0.1	-		
			Full	-	-1	-	-1	-		
Ground current	IGND		Room	-0.001	-0.1	-	-0.1	-		
			Full	-	-1	-	-1	-		



SPECIFICATIONS FOR SINGLE SUPPLIES (V+ = +3 V, V- = 0 V)										
PARAMETER	SYMBOL	TEST CONDITIONS UNLESS OTHERWISE SPECIFIED V+ = +3 V, V- = 0 V VIN = 1.4 V, 0.6 V <sup>a</sup>	TEMP. <sup>b</sup>	LIMITS					UNIT	
				TYP. <sup>c</sup>	-40 °C to +125 °C		-40 °C to +85 °C			
					MIN. <sup>d</sup>	MAX. <sup>d</sup>	MIN. <sup>d</sup>	MAX. <sup>d</sup>		
<b>Analog Switch</b>										
Analog signal range <sup>e</sup>	V <sub>ANALOG</sub>		Full	-	0	3	0	3	V	
Drain source On-resistance	R <sub>DS(on)</sub>	I <sub>S</sub> = 1 mA, V <sub>D</sub> = +1.5 V	Room	305	-	420	-	420	Ω	
			Full	-	-	600	-	500		
Switch off leakage current	I <sub>S(off)</sub>	V+ = 3.3 V, V- = 0 V V <sub>D</sub> = 3 V / 0.3 V V <sub>S</sub> = 0.3 V / 3 V	Room	±0.0005	-0.1	0.1	-0.1	0.1	nA	
			Full	-	-2	2	-0.25	0.25		
	Room		±0.006	-0.1	0.1	-0.1	0.1			
	Full		-	-2	2	-0.25	0.25			
Switch on leakage current	I <sub>D(on)</sub>	V+ = 3.3 V, V- = 0 V V <sub>D</sub> = V <sub>S</sub> = 0.3 V / 3 V	Room	±0.008	-0.1	0.1	-0.1	0.1		
			Full	-	-6	6	-0.25	0.25		
<b>Digital Control</b>										
Input current, V <sub>IN</sub> low	I <sub>IL</sub>	V <sub>IN</sub> under test = 0.6 V	Full	0.01	-0.1	0.1	-0.1	0.1	μA	
Input current, V <sub>IN</sub> high	I <sub>IH</sub>	V <sub>IN</sub> under test = 1.4 V	Full	0.01	-0.1	0.1	-0.1	0.1		
Input capacitance <sup>e</sup>	C <sub>IN</sub>	f = 1 MHz	Room	4	-	-	-	-	pF	
<b>Dynamic Characteristics</b>										
Turn-on time	t <sub>ON</sub>	R <sub>L</sub> = 300 Ω, C <sub>L</sub> = 35 pF V <sub>S</sub> = 2 V	Room	76	-	115	-	115	ns	
			Full	-	-	180	-	155		
Turn-off time	t <sub>OFF</sub>		Room	31	-	58	-	58		
			Full	-	-	65	-	60		
Break-before-make time delay	t <sub>BBM</sub>		DG613 only, V <sub>S</sub> = 2 V R <sub>L</sub> = 300 Ω, C <sub>L</sub> = 35 pF	Room	60	-	-	-		-
				Full	-	10	-	10		-
Charge injection <sup>e</sup>	Q <sub>INJ</sub>	V <sub>g</sub> = 0 V, R <sub>g</sub> = 0 Ω, C <sub>L</sub> = 1 nF	Room	1.4	-	-	-	-	pC	
Off isolation <sup>e</sup>	OIRR	R <sub>L</sub> = 50 Ω, C <sub>L</sub> = 5 pF f = 10 MHz	Room	-59	-	-	-	-	dB	
Channel-to-channel crosstalk <sup>e</sup>	X <sub>TALK</sub>		Room	-71	-	-	-	-		
Bandwidth <sup>e</sup>	BW		R <sub>L</sub> = 50 Ω, C <sub>L</sub> = 5 pF	Room	830	-	-	-		-
Source off capacitance <sup>e</sup>	C <sub>S(off)</sub>	f = 1 MHz; V <sub>S</sub> = 0 V	Room	3	-	-	-	-	pF	
Drain off capacitance <sup>e</sup>	C <sub>D(off)</sub>		Room	4	-	-	-	-		
Drain on capacitance <sup>e</sup>	C <sub>D(on)</sub>		f = 1 MHz; V <sub>S</sub> = V <sub>D</sub> = 0 V	Room	7	-	-	-		-
<b>Power Supplies</b>										
Power supply current	I+	V <sub>IN</sub> = 0 V or 3 V	Room	0.001	-	0.1	-	0.1	μA	
			Full	-	-	1	-	1		
Negative supply current	I-		Room	-0.001	-0.1	-	-0.1	-		
			Full	-	-1	-	-1	-		
Ground current	I <sub>GND</sub>		Room	-0.001	-0.1	-	-0.1	-		
			Full	-	-1	-	-1	-		

**Notes**

- a. V<sub>IN</sub> = input voltage to perform proper function
- b. Room = 25 °C, Full = as determined by the operating temperature suffix
- c. Typical values are for DESIGN AID ONLY, not guaranteed nor subject to production testing
- d. The algebraic convention whereby the most negative value is a minimum and the most positive a maximum, is used in this datasheet
- e. Guaranteed by design, not subject to production test

Stresses beyond those listed under "Absolute Maximum Ratings" may cause permanent damage to the device. These are stress ratings only, and functional operation of the device at these or any other conditions beyond those indicated in the operational sections of the specifications is not implied. Exposure to absolute maximum rating conditions for extended periods may affect device reliability.



TYPICAL CHARACTERISTICS (25 °C, unless otherwise noted)

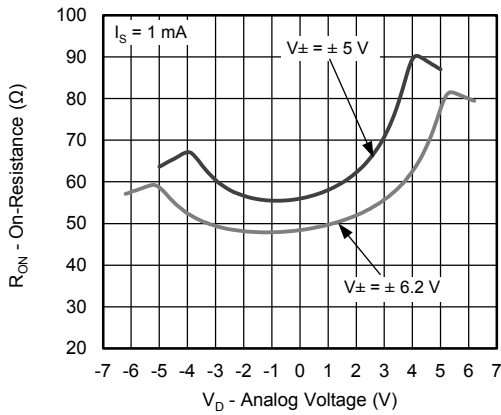

On-Resistance vs.  $V_D$  (Dual Supply)

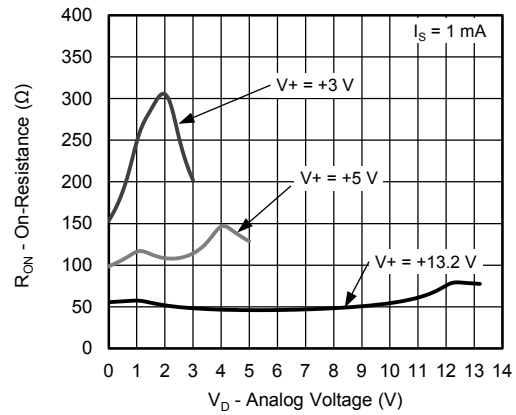

On-Resistance vs.  $V_D$  (Single Supply)

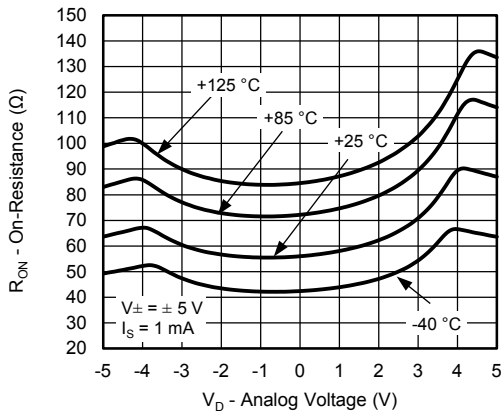

On-Resistance vs. Temperature (Dual Supply)

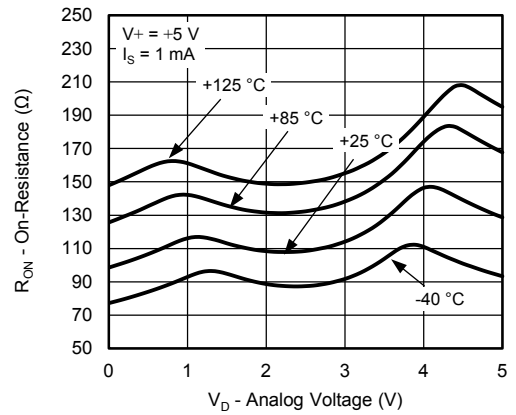

On-Resistance vs. Temperature (Single Supply)

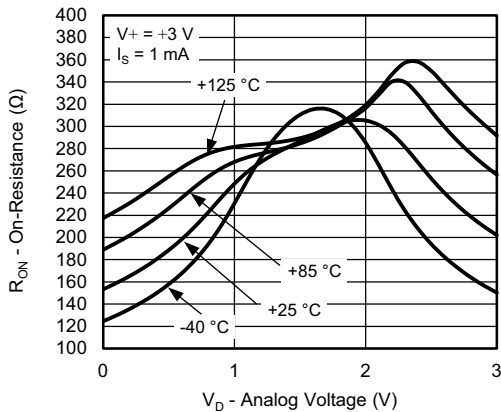

On-Resistance vs. Temperature (Single Supply)

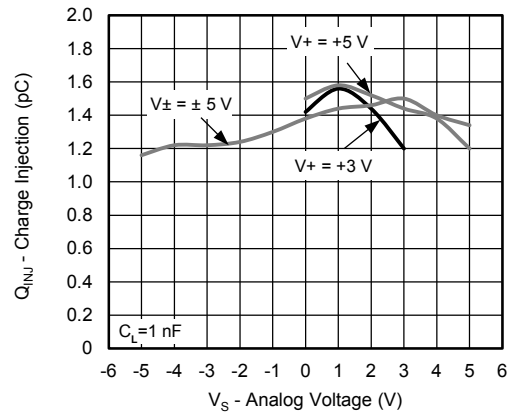

Charge Injection vs. Analog Voltage



TYPICAL CHARACTERISTICS (25 °C, unless otherwise noted)

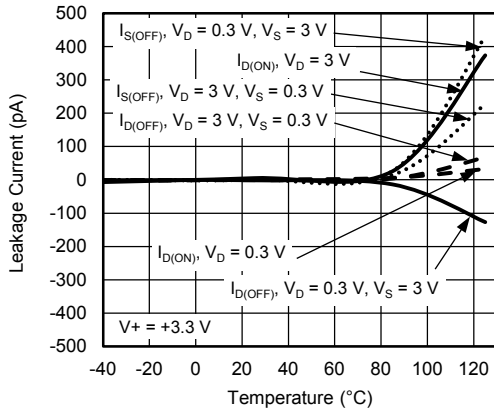

Leakage Current vs. Temperature

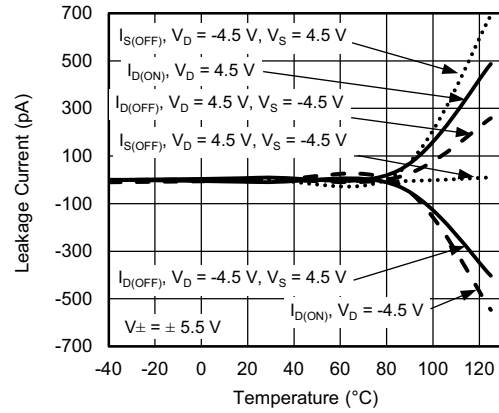

Leakage Current vs. Temperature

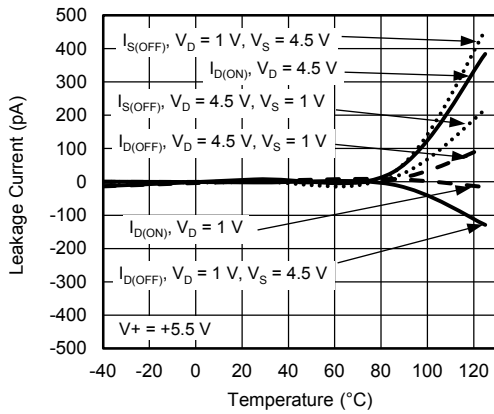

Leakage Current vs. Temperature

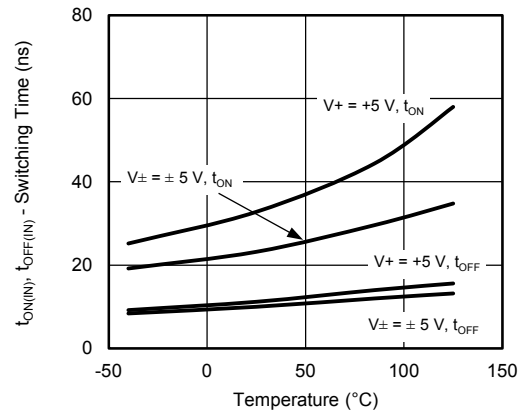

Switching Time vs. Temperature

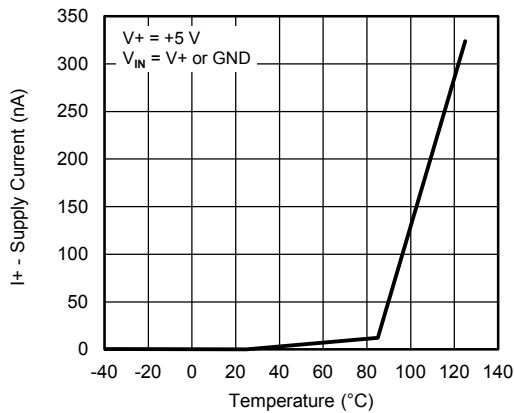

Supply Current vs. Temperature

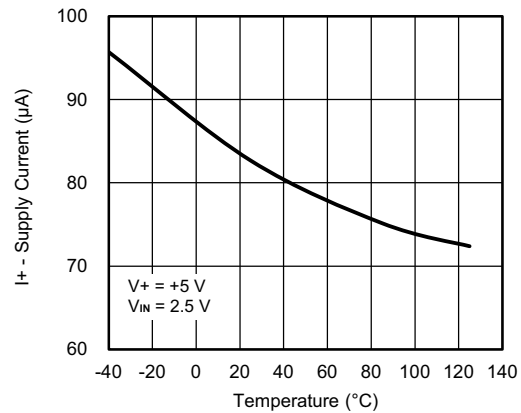

Supply Current vs. Temperature





TYPICAL CHARACTERISTICS (25 °C, unless otherwise noted)

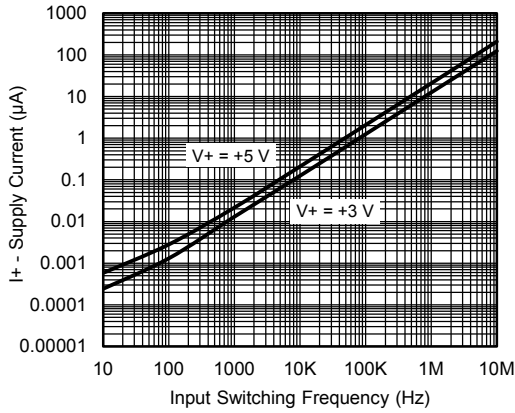

Supply Current vs. Switching Frequency

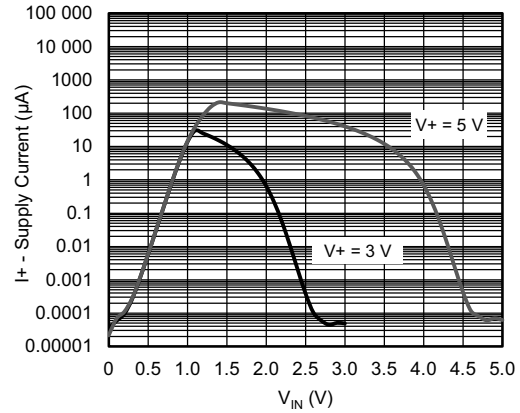

Supply Current vs. Input Voltage

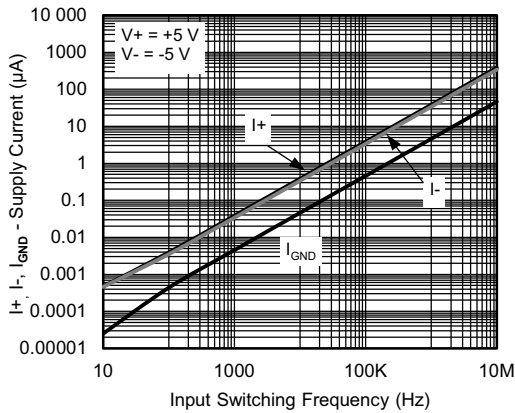

Supply Current vs. Switching Frequency

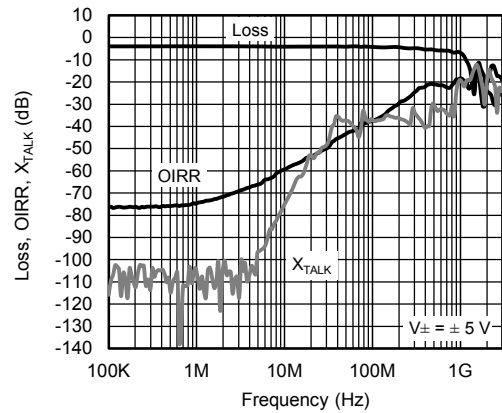

Insertion Loss, Off-Isolation, Crosstalk vs. Frequency

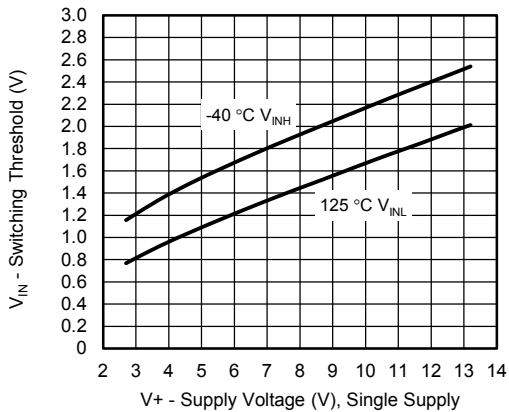

Switching Threshold vs. Supply Voltage (Single Supply)

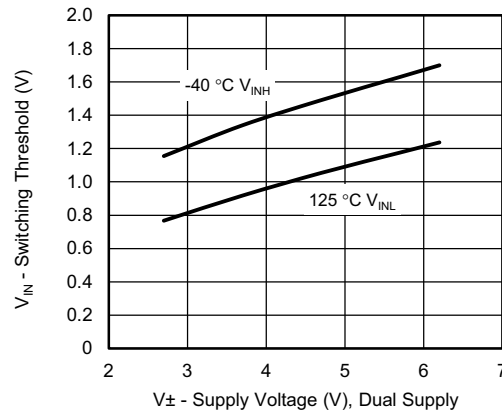

Switching Threshold vs. Supply Voltage (Dual Supply)

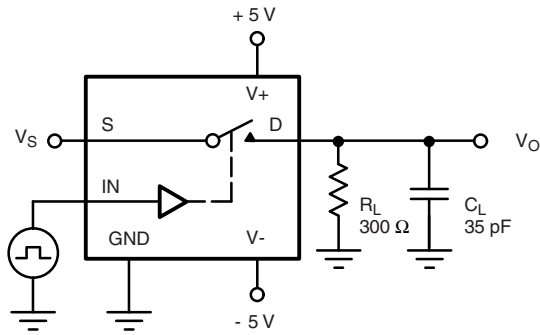
**TEST CIRCUITS**

 $C_L$  (includes fixture and stray capacitance)

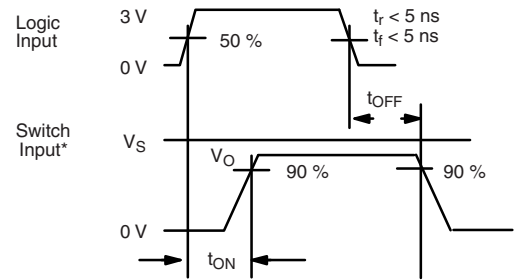
$$V_O = V_S \frac{R_L}{R_L + r_{DS(on)}}$$

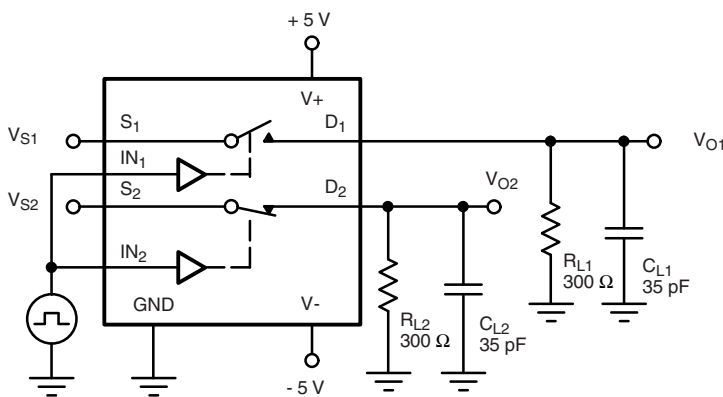
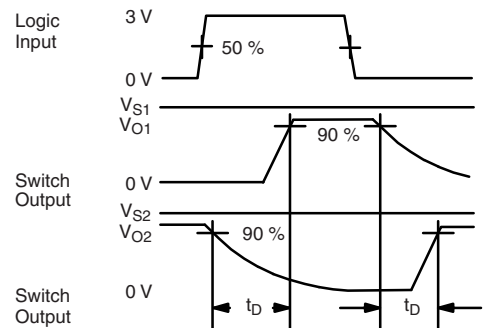
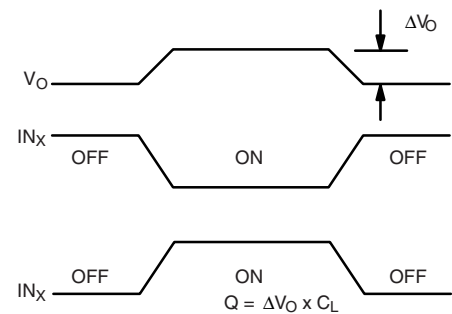
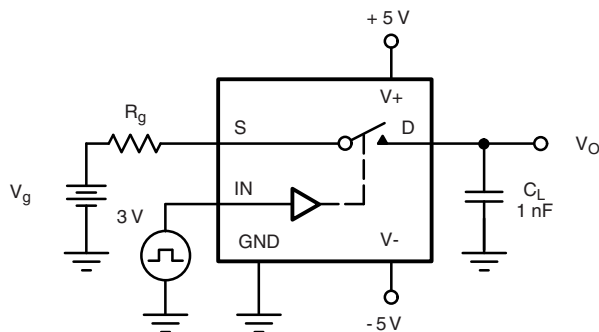

Note: Logic input waveform is inverted for switches that have the opposite logic sense control

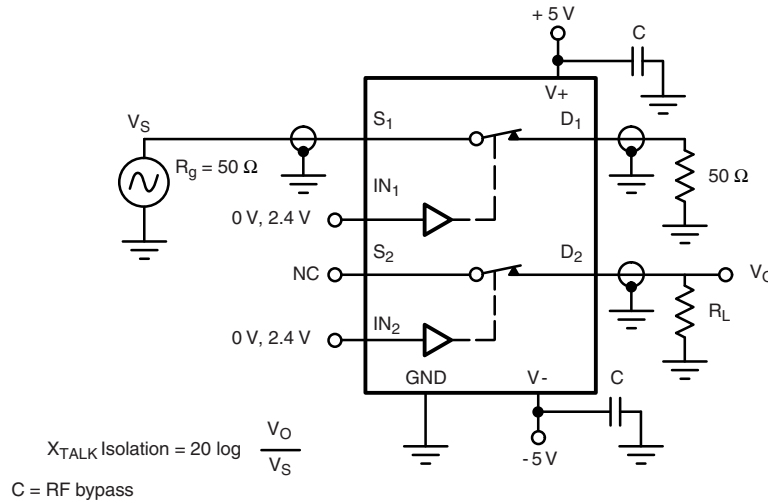
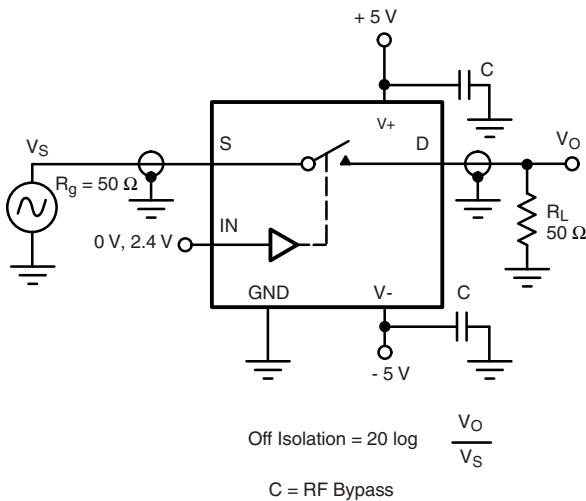
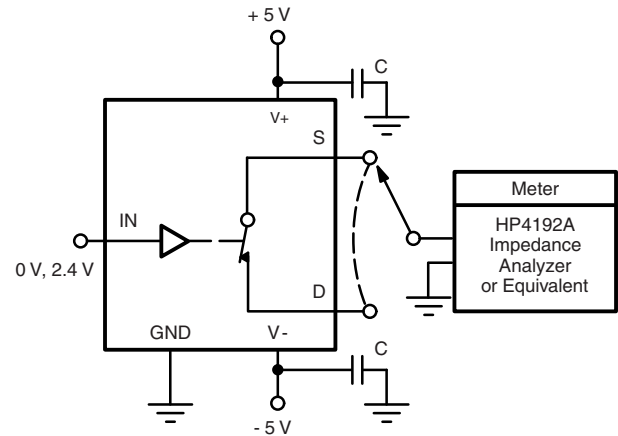
**Fig. 1 - Switching Time**

 $C_L$  (includes fixture and stray capacitance)

**Fig. 2 - Break-Before-Make (DG613E)**

**Fig. 3 - Charge Injection**

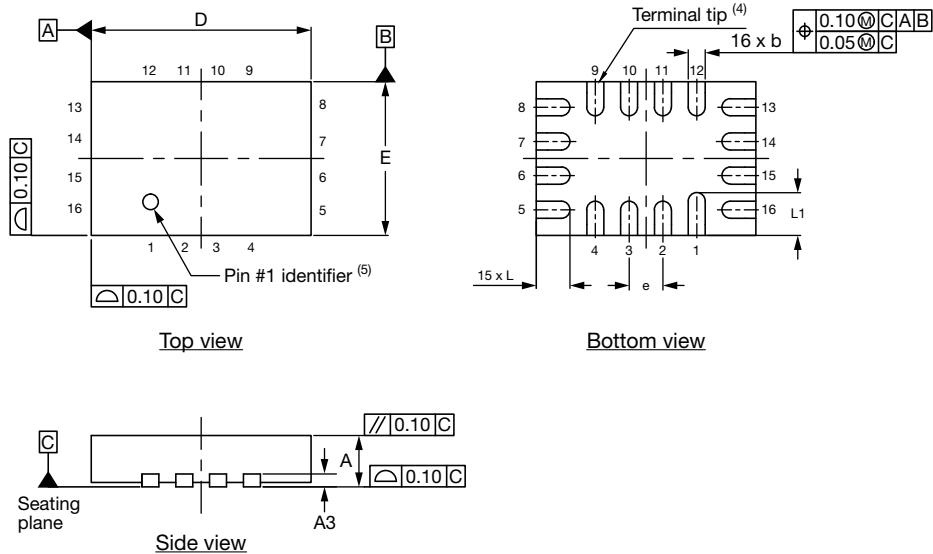
**TEST CIRCUITS**

**Fig. 4 - Crosstalk**

**Fig. 5 - Off-Isolation**

**Fig. 6 - Source / Drain Capacitances**

Vishay Siliconix maintains worldwide manufacturing capability. Products may be manufactured at one of several qualified locations. Reliability data for Silicon Technology and Package Reliability represent a composite of all qualified locations. For related documents such as package / tape drawings, part marking, and reliability data, see [www.vishay.com/ppg?78910](http://www.vishay.com/ppg?78910).

## Thin miniQFN16 Case Outline



DIMENSIONS	MILLIMETERS <sup>(1)</sup>			INCHES		
	MIN.	NOM.	MAX.	MIN.	NOM.	MAX.
A	0.50	0.55	0.60	0.020	0.022	0.024
A1	0	-	0.05	0	-	0.002
A3	0.15 ref.			0.006 ref.		
b	0.15	0.20	0.25	0.006	0.008	0.010
D	2.50	2.60	2.70	0.098	0.102	0.106
e	0.40 BSC			0.016 BSC		
E	1.70	1.80	1.90	0.067	0.071	0.075
L	0.35	0.40	0.45	0.014	0.016	0.018
L1	0.45	0.50	0.55	0.018	0.020	0.022
N <sup>(3)</sup>	16			16		
Nd <sup>(3)</sup>	4			4		
Ne <sup>(3)</sup>	4			4		

### Notes

- (1) Use millimeters as the primary measurement.
- (2) Dimensioning and tolerances conform to ASME Y14.5M. - 1994.
- (3) N is the number of terminals. Nd and Ne is the number of terminals in each D and E site respectively.
- (4) Dimensions b applies to plated terminal and is measured between 0.15 mm and 0.30 mm from terminal tip.
- (5) The pin 1 identifier must be existed on the top surface of the package by using identification mark or other feature of package body.
- (6) Package warpage max. 0.05 mm.

ECN: T16-0226-Rev. B, 09-May-16  
DWG: 6023



**SOIC (NARROW): 16-LEAD**  
JEDEC Part Number: MS-012

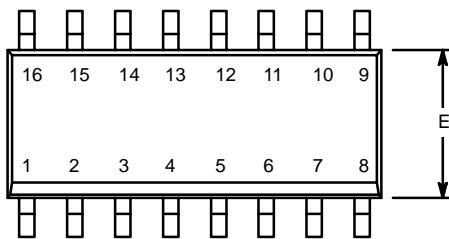

Dim	MILLIMETERS		INCHES	
	Min	Max	Min	Max
A	1.35	1.75	0.053	0.069
A <sub>1</sub>	0.10	0.20	0.004	0.008
B	0.38	0.51	0.015	0.020
C	0.18	0.23	0.007	0.009
D	9.80	10.00	0.385	0.393
E	3.80	4.00	0.149	0.157
e	1.27 BSC		0.050 BSC	
H	5.80	6.20	0.228	0.244
L	0.50	0.93	0.020	0.037
∅	0°	8°	0°	8°

ECN: S-03946—Rev. F, 09-Jul-01  
DWG: 5300

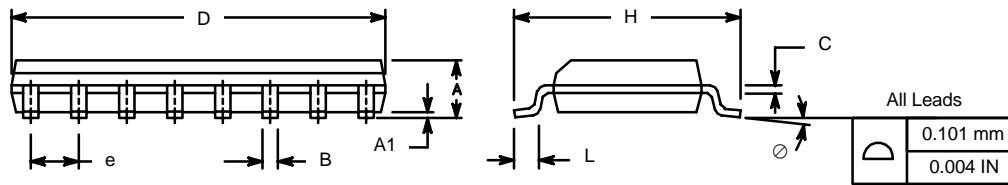

## TSSOP: 16-LEAD

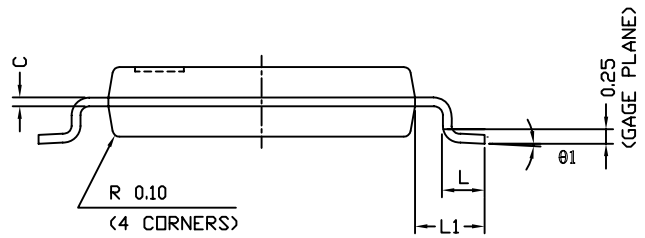
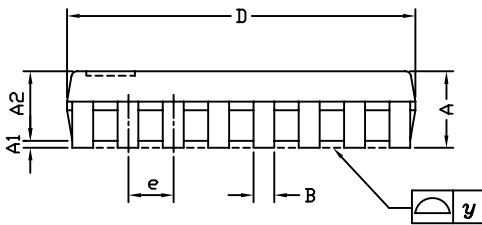
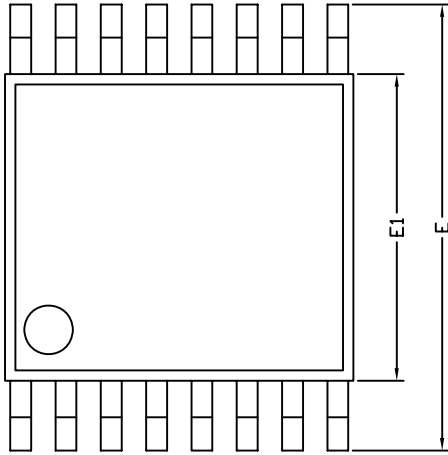

Symbols	DIMENSIONS IN MILLIMETERS		
	Min	Nom	Max
A	-	1.10	1.20
A1	0.05	0.10	0.15
A2	-	1.00	1.05
B	0.22	0.28	0.38
C	-	0.127	-
D	4.90	5.00	5.10
E	6.10	6.40	6.70
E1	4.30	4.40	4.50
e	-	0.65	-
L	0.50	0.60	0.70
L1	0.90	1.00	1.10
y	-	-	0.10
theta1	0°	3°	6°

ECN: S-61920-Rev. D, 23-Oct-06  
DWG: 5624



## RECOMMENDED MINIMUM PAD FOR TSSOP-16

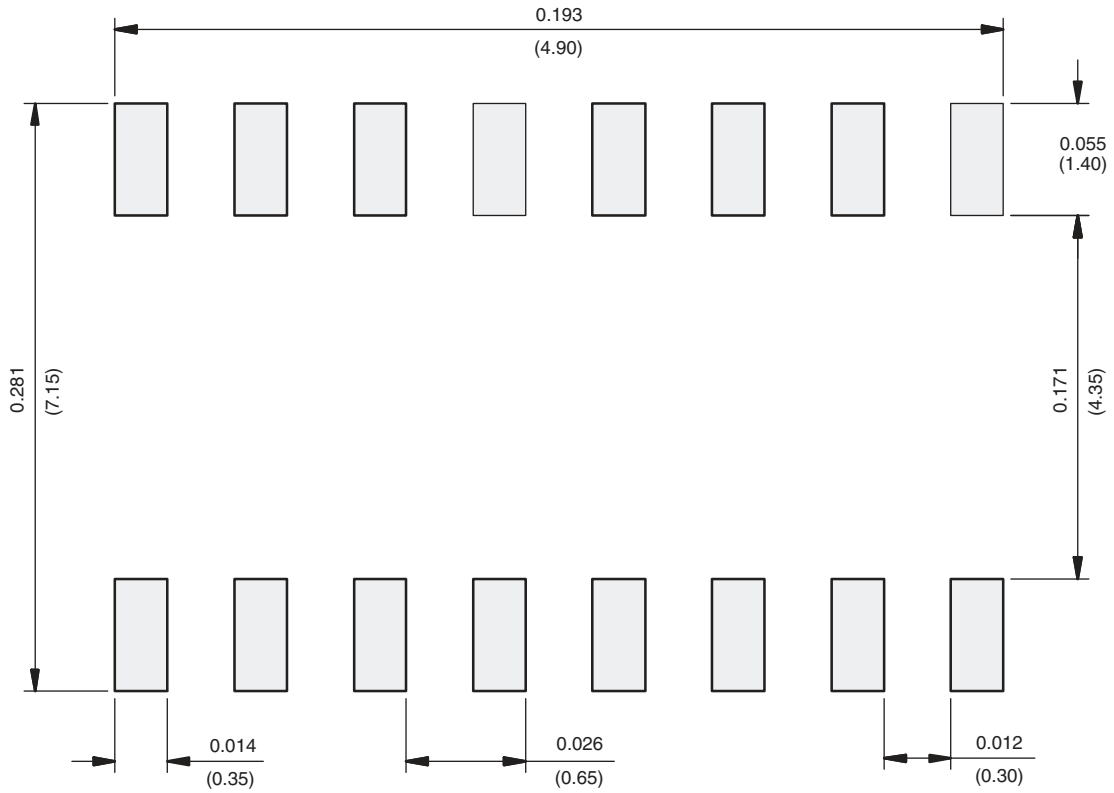

Recommended Minimum Pads  
Dimensions in inches (mm)

**RECOMMENDED MINIMUM PADS FOR MINI QFN 16L**

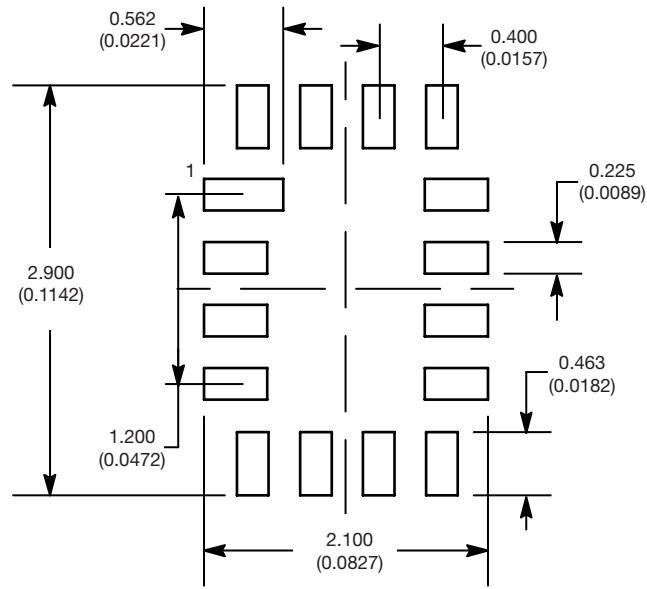

Mounting Footprint  
Dimensions in mm (inch)



## RECOMMENDED MINIMUM PADS FOR SO-16

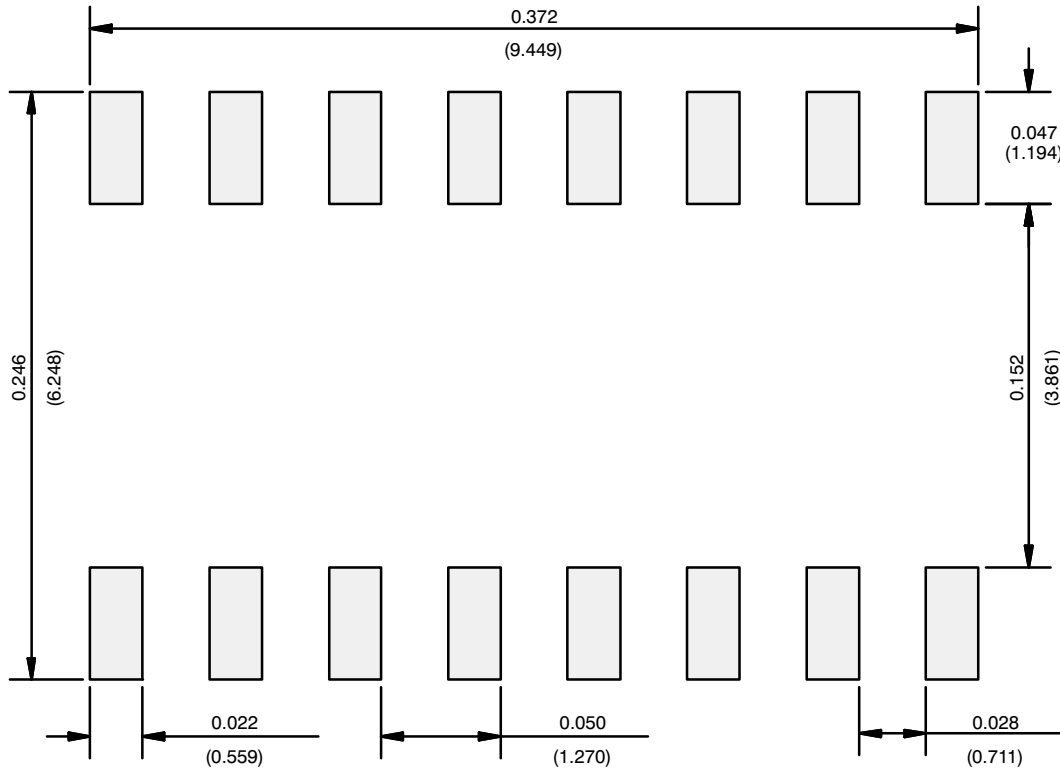

Recommended Minimum Pads  
Dimensions in Inches/(mm)

[Return to Index](#)



## **Disclaimer**

ALL PRODUCT, PRODUCT SPECIFICATIONS AND DATA ARE SUBJECT TO CHANGE WITHOUT NOTICE TO IMPROVE RELIABILITY, FUNCTION OR DESIGN OR OTHERWISE.

Vishay Intertechnology, Inc., its affiliates, agents, and employees, and all persons acting on its or their behalf (collectively, "Vishay"), disclaim any and all liability for any errors, inaccuracies or incompleteness contained in any datasheet or in any other disclosure relating to any product.

Vishay makes no warranty, representation or guarantee regarding the suitability of the products for any particular purpose or the continuing production of any product. To the maximum extent permitted by applicable law, Vishay disclaims (i) any and all liability arising out of the application or use of any product, (ii) any and all liability, including without limitation special, consequential or incidental damages, and (iii) any and all implied warranties, including warranties of fitness for particular purpose, non-infringement and merchantability.

Statements regarding the suitability of products for certain types of applications are based on Vishay's knowledge of typical requirements that are often placed on Vishay products in generic applications. Such statements are not binding statements about the suitability of products for a particular application. It is the customer's responsibility to validate that a particular product with the properties described in the product specification is suitable for use in a particular application. Parameters provided in datasheets and / or specifications may vary in different applications and performance may vary over time. All operating parameters, including typical parameters, must be validated for each customer application by the customer's technical experts. Product specifications do not expand or otherwise modify Vishay's terms and conditions of purchase, including but not limited to the warranty expressed therein.

Hyperlinks included in this datasheet may direct users to third-party websites. These links are provided as a convenience and for informational purposes only. Inclusion of these hyperlinks does not constitute an endorsement or an approval by Vishay of any of the products, services or opinions of the corporation, organization or individual associated with the third-party website. Vishay disclaims any and all liability and bears no responsibility for the accuracy, legality or content of the third-party website or for that of subsequent links.

Except as expressly indicated in writing, Vishay products are not designed for use in medical, life-saving, or life-sustaining applications or for any other application in which the failure of the Vishay product could result in personal injury or death. Customers using or selling Vishay products not expressly indicated for use in such applications do so at their own risk. Please contact authorized Vishay personnel to obtain written terms and conditions regarding products designed for such applications.

No license, express or implied, by estoppel or otherwise, to any intellectual property rights is granted by this document or by any conduct of Vishay. Product names and markings noted herein may be trademarks of their respective owners.