



MICROCHIP

**MCP6L2 and PIC18F66J93
Energy Meter
Reference Design**

Note the following details of the code protection feature on Microchip devices:

- Microchip products meet the specification contained in their particular Microchip Data Sheet.
- Microchip believes that its family of products is one of the most secure families of its kind on the market today, when used in the intended manner and under normal conditions.
- There are dishonest and possibly illegal methods used to breach the code protection feature. All of these methods, to our knowledge, require using the Microchip products in a manner outside the operating specifications contained in Microchip's Data Sheets. Most likely, the person doing so is engaged in theft of intellectual property.
- Microchip is willing to work with the customer who is concerned about the integrity of their code.
- Neither Microchip nor any other semiconductor manufacturer can guarantee the security of their code. Code protection does not mean that we are guaranteeing the product as "unbreakable."

Code protection is constantly evolving. We at Microchip are committed to continuously improving the code protection features of our products. Attempts to break Microchip's code protection feature may be a violation of the Digital Millennium Copyright Act. If such acts allow unauthorized access to your software or other copyrighted work, you may have a right to sue for relief under that Act.

Information contained in this publication regarding device applications and the like is provided only for your convenience and may be superseded by updates. It is your responsibility to ensure that your application meets with your specifications. MICROCHIP MAKES NO REPRESENTATIONS OR WARRANTIES OF ANY KIND WHETHER EXPRESS OR IMPLIED, WRITTEN OR ORAL, STATUTORY OR OTHERWISE, RELATED TO THE INFORMATION, INCLUDING BUT NOT LIMITED TO ITS CONDITION, QUALITY, PERFORMANCE, MERCHANTABILITY OR FITNESS FOR PURPOSE. Microchip disclaims all liability arising from this information and its use. Use of Microchip devices in life support and/or safety applications is entirely at the buyer's risk, and the buyer agrees to defend, indemnify and hold harmless Microchip from any and all damages, claims, suits, or expenses resulting from such use. No licenses are conveyed, implicitly or otherwise, under any Microchip intellectual property rights.

Trademarks

The Microchip name and logo, the Microchip logo, dsPIC, FlashFlex, KEELOQ, KEELOQ logo, MPLAB, PIC, PICmicro, PICSTART, PIC³² logo, rPIC, SST, SST Logo, SuperFlash and UNI/O are registered trademarks of Microchip Technology Incorporated in the U.S.A. and other countries.

FilterLab, Hampshire, HI-TECH C, Linear Active Thermistor, MTP, SEEVAL and The Embedded Control Solutions Company are registered trademarks of Microchip Technology Incorporated in the U.S.A.

Silicon Storage Technology is a registered trademark of Microchip Technology Inc. in other countries.

Analog-for-the-Digital Age, Application Maestro, BodyCom, chipKIT, chipKIT logo, CodeGuard, dsPICDEM, dsPICDEM.net, dsPICworks, dsSPEAK, ECAN, ECONOMONITOR, FanSense, HI-TIDE, In-Circuit Serial Programming, ICSP, Mindi, MiWi, MPASM, MPF, MPLAB Certified logo, MPLIB, MPLINK, mTouch, Omniscent Code Generation, PICC, PICC-18, PICDEM, PICDEM.net, PICkit, PICtail, REAL ICE, rLAB, Select Mode, SQI, Serial Quad I/O, Total Endurance, TSHARC, UniWinDriver, WiperLock, ZENA and Z-Scale are trademarks of Microchip Technology Incorporated in the U.S.A. and other countries.

SQTP is a service mark of Microchip Technology Incorporated in the U.S.A.

GestIC and ULPP are registered trademarks of Microchip Technology Germany II GmbH & Co. & KG, a subsidiary of Microchip Technology Inc., in other countries.

All other trademarks mentioned herein are property of their respective companies.

© 2012-2013, Microchip Technology Incorporated, Printed in the U.S.A., All Rights Reserved.

 Printed on recycled paper.

ISBN: 978-1-62076-090-4

QUALITY MANAGEMENT SYSTEM
CERTIFIED BY DNV
== ISO/TS 16949 ==

Microchip received ISO/TS-16949:2009 certification for its worldwide headquarters, design and wafer fabrication facilities in Chandler and Tempe, Arizona; Gresham, Oregon and design centers in California and India. The Company's quality system processes and procedures are for its PIC[®] MCUs and dsPIC[®] DSCs, KEELOQ[®] code hopping devices, Serial EEPROMs, microperipherals, nonvolatile memory and analog products. In addition, Microchip's quality system for the design and manufacture of development systems is ISO 9001:2000 certified.

Object of Declaration: MCP6L2 and PIC18F66J93 Energy Meter Reference Design

EU Declaration of Conformity

This declaration of conformity is issued by the manufacturer.

The development/evaluation tool is designed to be used for research and development in a laboratory environment. This development/evaluation tool is not intended to be a finished appliance, nor is it intended for incorporation into finished appliances that are made commercially available as single functional units to end users. This development/evaluation tool complies with EU EMC Directive 2004/108/EC and as supported by the European Commission's Guide for the EMC Directive 2004/108/EC (8th February 2010).

This development/evaluation tool complies with EU RoHS2 Directive 2011/65/EU.

For information regarding the exclusive, limited warranties applicable to Microchip products, please see Microchip's standard terms and conditions of sale, which are printed on our sales documentation and available at www.microchip.com.

Signed for and on behalf of Microchip Technology Inc. at Chandler, Arizona, USA



Derek Carlson
VP Development Tools

02-MAY-12
Date

MCP6L2 and PIC18F66J93 Energy Meter Reference Design

NOTES:

Table of Contents

Preface	9
Introduction.....	9
Document Layout	10
Conventions Used in this Guide	11
Recommended Reading.....	12
The Microchip Web Site	12
Customer Support	12
Document Revision History	12
 Chapter 1. Product Overview	
1.1 Introduction	13
1.2 What Does the MCP6L2 and PIC18F66J93 Energy Meter Kit Include?	14
1.3 Getting Started	14
1.3.1 Step 1: Wiring Connections	14
1.3.2 Step 2: Turn On Line/Load Power to the Meter (Power the Meter)	14
 Chapter 2. Hardware	
2.1 Overview	15
2.2 Input and Analog Front End	18
2.3 Power Supply Circuit	20
 Chapter 3. Calculation Engine and Register Description	
3.1 COHERENT SAMPLING ALGORITHM	21
3.1.1 The Advantages of the Coherent Sampling in this Energy Metering Design	21
3.1.2 Coherent Sampling Algorithm	22
3.2 Calculation Engine Signal Flow Summary	23
3.3 Complete Register List	24
3.4 METER_VERSION_ID	25
3.5 METER_STATUS	25
3.6 CAL_CONTROL	26
3.7 RAW_I_RMS	26
3.8 I_RMS	27
3.9 RAW_V_RMS	27
3.10 V_RMS	27
3.11 FREQUENCY	27
3.12 POWER_ACT	27
3.13 POWER_REACT	28
3.14 POWER_APP	28

MCP6L2 and PIC18F66J93 Energy Meter Reference Design

3.15 POWER_FACTOR	28
3.16 PHASE_COMPENSATION	28
3.17 GAIN_I_RMS	29
3.18 GAIN_POWER_ACT	29
3.19 GAIN_POWER_REACT	29
3.20 GAIN_NUMR_ENERGY_ACT	29
3.21 GAIN_DENR_ENERGY_ACT	30
3.22 GAIN_NUMR_ENERGY_REACT	30
3.23 GAIN_DENR_ENERGY_REACT	30
3.24 PHASE_COMPENSATION_LOW	30
3.25 PHASE_COMPENSATION_HIGH	31
3.26 GAIN_V_RMS	31
3.27 GAIN_I_RMS_LOW	31
3.28 GAIN_I_RMS_HIGH	31
3.29 GAIN_POWER_ACT_LOW	31
3.30 GAIN_POWER_ACT_HIGH	32
3.31 GAIN_NUMR_ENERGY_ACT_LOW	32
3.32 GAIN_NUMR_ENERGY_ACT_HIGH	32
3.33 GAIN_DENR_ENERGY_ACT_LOW	32
3.34 GAIN_DENR_ENERGY_ACT_HIGH	32
3.35 GAIN_POWER_REACT_LOW	32
3.36 GAIN_POWER_REACT_HIGH	33
3.37 GAIN_NUMR_ENERGY_REACT_LOW	33
3.38 GAIN_NUMR_ENERGY_REACT_HIGH	33
3.39 GAIN_DENR_ENERGY_REACT_LOW	33
3.40 GAIN_DENR_ENERGY_REACT_HIGH	33
3.41 METER_CONSTANT	34
3.42 PULSE_WIDTH	34
3.43 NO_LOAD_THRESHOLD_I_RMS	34
3.44 LINE_CYC	34
3.45 ENERGY_ACT	35
3.46 ENERGY_REACT	35

Chapter 4. Communication Protocol

4.1 Protocol	37
4.1.1 Command Description	37

Chapter 5. Microchip Energy Meter Software

5.1 Overview	41
5.2 The Main Screen	41
5.3 Debug Mode	43
5.3.1 Refreshing Registers Status	43
5.3.2 Monitoring Individual Registers	44
5.3.3 Writing to Individual Registers	44

Chapter 6. Energy Meter Calibration

6.1 Introduction	45
6.2 Calibration Registers	45
6.3 Closed Loop Calibration	46
6.3.1 Closed Loop Calibration Principle	46
6.3.2 Closed Loop Calibration with Microchip Energy Meter Software	47
6.4 Open Loop Calibration	50
6.4.1 Open Loop Calibration Principle	50
6.4.2 Open Loop Calibration with Energy Meter GUI	51
6.5 Auto-Calibration	54
6.5.1 Auto-Calibration Principle	54
6.5.2 Auto-Calibration with Energy Meter GUI	55

Appendix A. Schematic and Layouts

A.1 Introduction	57
A.2 Schematics and PCB Layout	57
A.3 Board – Schematic – Analog-to-Digital Converter	58
A.4 Board – Schematic – Microcontroller	59
A.5 Board – Schematic – LCD - USB	60
A.6 Board – Top Silk	61
A.7 Board – Top Copper	62
A.8 Board – Top Silk and Copper	63
A.9 Board – Bottom Silk	64
A.10 Board – Bottom Copper	65
A.11 Board – Bottom Silk and Copper	66

Appendix B. Bill of Materials (BOM)

Worldwide Sales and Service	70
-----------------------------------	----

MCP6L2 and PIC18F66J93 Energy Meter Reference Design

NOTES:



MCP6L2 AND PIC18F66J93 ENERGY METER REFERENCE DESIGN

Preface

NOTICE TO CUSTOMERS

All documentation becomes dated, and this manual is no exception. Microchip tools and documentation are constantly evolving to meet customer needs, so some actual dialogs and/or tool descriptions may differ from those in this document. Please refer to our web site (www.microchip.com) to obtain the latest documentation available.

Documents are identified with a “DS” number. This number is located on the bottom of each page, in front of the page number. The numbering convention for the DS number is “DSXXXXA”, where “XXXX” is the document number and “A” is the revision level of the document.

For the most up-to-date information on development tools, see the MPLAB® IDE online help. Select the Help menu, and then Topics to open a list of available online help files.

INTRODUCTION

This chapter contains general information that will be useful to know before using the MCP6L2 and PIC18F66J93 Energy Meter Reference Design. Items discussed in this chapter include:

- Document Layout
- Conventions Used in this Guide
- Recommended Reading
- The Microchip Web Site
- Customer Support
- Document Revision History

MCP6L2 and PIC18F66J93 Energy Meter Reference Design

DOCUMENT LAYOUT

This document describes how to use the MCP6L2 and PIC18F66J93 Energy Meter as a development tool to emulate and debug firmware on a target board. The manual layout is as follows:

- **Chapter 1. “Product Overview”** – Important information on using the MCP6L2 and PIC18F66J93 Energy Meter including a Getting Started section that describes wiring the line and load connections.
- **Chapter 2. “Hardware”** – Includes details about the function blocks of the meter including the analog front-end and power supply design.
- **Chapter 3. “Calculation Engine and Register Description”** – This section describes the digital signal flow for all power output quantities such as RMS current, RMS voltage, active power, reactive power and apparent power. This section also includes the registers’ detail.
- **Chapter 4. “Communication Protocol”** – The protocol used for accessing the registers is described. It includes commands that are used to interface to the meter.
- **Chapter 5. “Microchip Energy Meter Software”** – Describes the functionality of the Graphical User Interface (GUI) that runs on the PC.
- **Chapter 6. “Energy Meter Calibration”** – Information on calibration of the energy meter using the GUI.
- **Appendix A. “Schematic and Layouts”** – Shows the schematic and layout diagrams
- **Appendix B. “Bill of Materials (BOM)”** – Lists the parts used to build the MCP6L2 and PIC18F66J93 Energy Meter.

CONVENTIONS USED IN THIS GUIDE

This manual uses the following documentation conventions:

DOCUMENTATION CONVENTIONS

Description	Represents	Examples
Arial font:		
Italic characters	Referenced books	<i>MPLAB[®] IDE User's Guide</i>
	Emphasized text	...is the <i>only</i> compiler...
Initial caps	A window	the Output window
	A dialog	the Settings dialog
	A menu selection	select Enable Programmer
Quotes	A field name in a window or dialog	"Save project before build"
Underlined, italic text with right angle bracket	A menu path	<u><i>File>Save</i></u>
Bold characters	A dialog button	Click OK
	A tab	Click the Power tab
N'Rnnnn	A number in verilog format, where N is the total number of digits, R is the radix and n is a digit.	4'b0010, 2'hF1
Text in angle brackets < >	A key on the keyboard	Press <Enter>, <F1>
Courier New font:		
Plain Courier New	Sample source code	#define START
	Filenames	autoexec.bat
	File paths	c:\mcc18\h
	Keywords	_asm, _endasm, static
	Command-line options	-Opa+, -Opa-
	Bit values	0, 1
	Constants	0xFF, 'A'
Italic Courier New	A variable argument	<i>file.o</i> , where <i>file</i> can be any valid filename
Square brackets []	Optional arguments	mcc18 [options] <i>file</i> [options]
Curly brackets and pipe character: { }	Choice of mutually exclusive arguments; an OR selection	errorlevel {0 1}
Ellipses...	Replaces repeated text	var_name [, var_name...]
	Represents code supplied by user	void main (void) { ... }

MCP6L2 and PIC18F66J93 Energy Meter Reference Design

RECOMMENDED READING

This user's guide describes how to use the MCP6L2 and PIC18F66J93 Energy Meter. Other useful documents are listed below. The following Microchip documents are available and recommended as supplemental reference resources.

- **MCP6L2 Data Sheet – “2.8 MHz, 200 μ A Op Amps” (DS22135)**

This data sheet provides detailed information regarding the MCP6L2 device.

- **PIC18F66J93 Data Sheet – “64/80-Pin, High-Performance Microcontrollers with LCD Driver, 12-Bit A/D and nanoWatt Technology” (DS39948)**

This data sheet provides detailed information regarding the PIC18F66J93 device.

- **PIC18F87J72 Single-Phase Energy Meter Calibration User's Guide (DS51964)**

This User's Guide describes the calibration registers and Universal Asynchronous Receiver/Transmitter (UART) communication protocol used on the PIC18F87J72 Single-Phase Energy Meter Reference Design. Only some of the information applies to the MCP6L2 and PIC18F66J93 Energy Meter Reference Design. The chapters recommended for reading will be specified later in this document.

THE MICROCHIP WEB SITE

Microchip provides online support via our web site at www.microchip.com. This web site is used as a means to make files and information easily available to customers. Accessible by using your favorite Internet browser, the web site contains the following information:

- **Product Support** – Data sheets and errata, application notes and sample programs, design resources, user's guides and hardware support documents, latest software releases and archived software
- **General Technical Support** – Frequently Asked Questions (FAQs), technical support requests, online discussion groups, Microchip consultant program member listing
- **Business of Microchip** – Product selector and ordering guides, latest Microchip press releases, listing of seminars and events, listings of Microchip sales offices, distributors and factory representatives

CUSTOMER SUPPORT

Users of Microchip products can receive assistance through several channels:

- Distributor or Representative
- Local Sales Office
- Field Application Engineer (FAE)
- Technical Support

Customers should contact their distributor, representative or field application engineer (FAE) for support. Local sales offices are also available to help customers. A listing of sales offices and locations is included in the back of this document.

Technical support is available through the web site at:

<http://www.microchip.com/support>.

DOCUMENT REVISION HISTORY

Revision B (February 2013)

- Updated [Figure 1-2](#).

Revision A (August 2012)

- Initial Release of this Document.

Chapter 1. Product Overview

1.1 INTRODUCTION

The MCP6L2 and PIC18F66J93 Energy Meter is a fully functional single-phase meter that uses the 12-bit successive approximation analog-to-digital converter (SAR ADC) integrated in the microcontroller. This low-cost design has a shunt as the current sensor. The signal from the shunt is amplified by two external operational amplifiers and applied to the input of the ADC. The PIC18F66J93 directly drives the LCD and communicates via UART with the MCP2200, offering an isolated USB connection for meter calibration and access to the device power calculations. The system calculates active and reactive energy; active, reactive and apparent power; power factor; RMS current; RMS voltage, and line frequency.

The Microchip energy meter software is used to calibrate and monitor the system. The calibration can be done in closed loop or open loop. When connected to a stable source of voltage and current, the meter can do an auto-calibration by including the open loop calibration routine and formulas in the firmware.

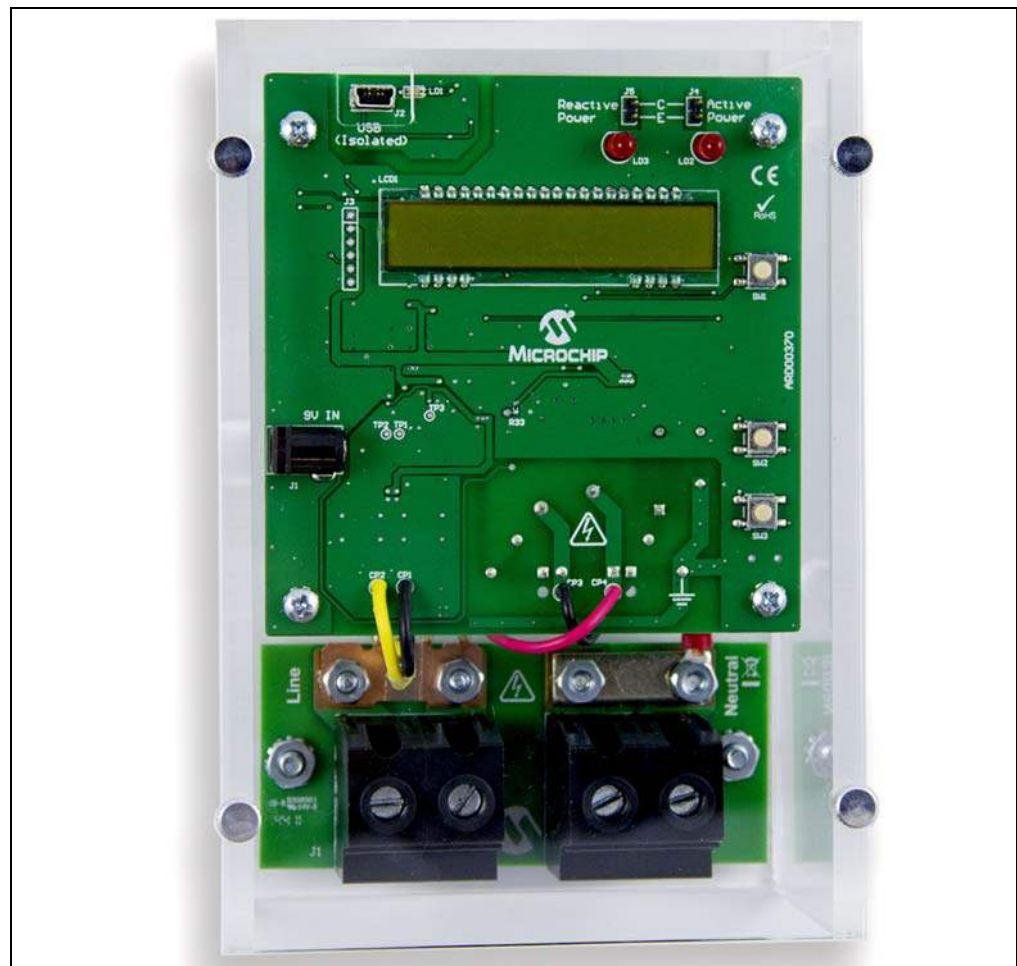

FIGURE 1-1: MCP6L2 and PIC18F66J93 Energy Meter Reference Design.

MCP6L2 and PIC18F66J93 Energy Meter Reference Design

1.2 WHAT DOES THE MCP6L2 AND PIC18F66J93 ENERGY METER KIT INCLUDE?

This MCP6L2 and PIC18F66J93 Energy Meter kit includes:

- MCP6L2 and PIC18F66J93 Energy Meter (ARD00370)
- Important Information Sheet

1.3 GETTING STARTED

To illustrate how to use the MCP6L2 and PIC18F66J93 Energy Meter, the following example is shown using a two-wire 1-phase, 220 VAC line voltage and connections using energy meter calibrator equipment, or other programmable load source. The nominal current (I_N) is 5A, and the maximum current (I_{MAX}) is 60A. The energy meter was designed for 50 Hz line systems.

All connections described in this section are dependent upon the choice of the current sensing element. A secondary external transformer may be required in higher current meter designs. To test a calibrated meter, the following connections apply for a two-wire connection.

1.3.1 Step 1: Wiring Connections

Figure 1-2 is identifying the line and load connections of the MCP6L2 and PIC18F66J93 Energy Meter.

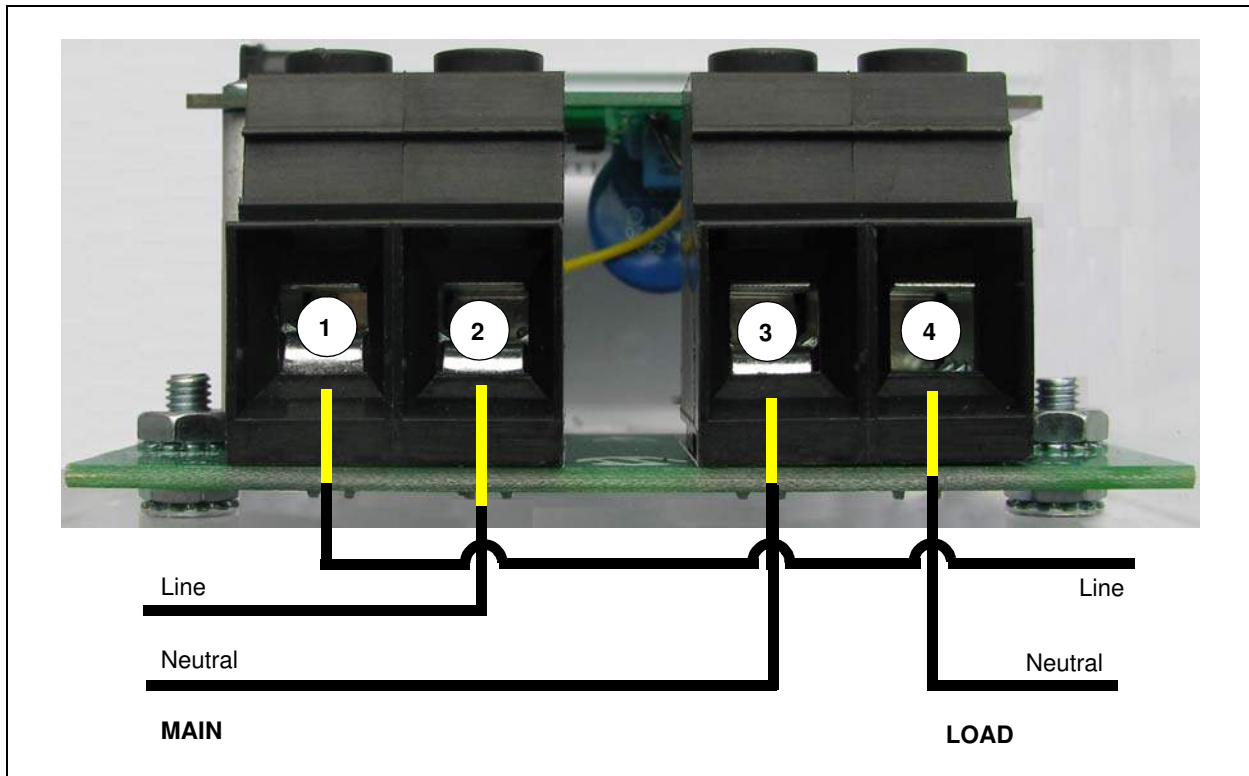

FIGURE 1-2: Example Connections using a Two-Wire System.

1.3.2 Step 2: Turn On Line/Load Power to the Meter (Power the Meter)

The meter will turn on when the line connection has 220V connected. The LCD display will show the total energy accumulated.

Chapter 2. Hardware

2.1 OVERVIEW

Figures 2-1 and 2-2 show the MCP6L2 and PIC18F66J93 Energy Meter:

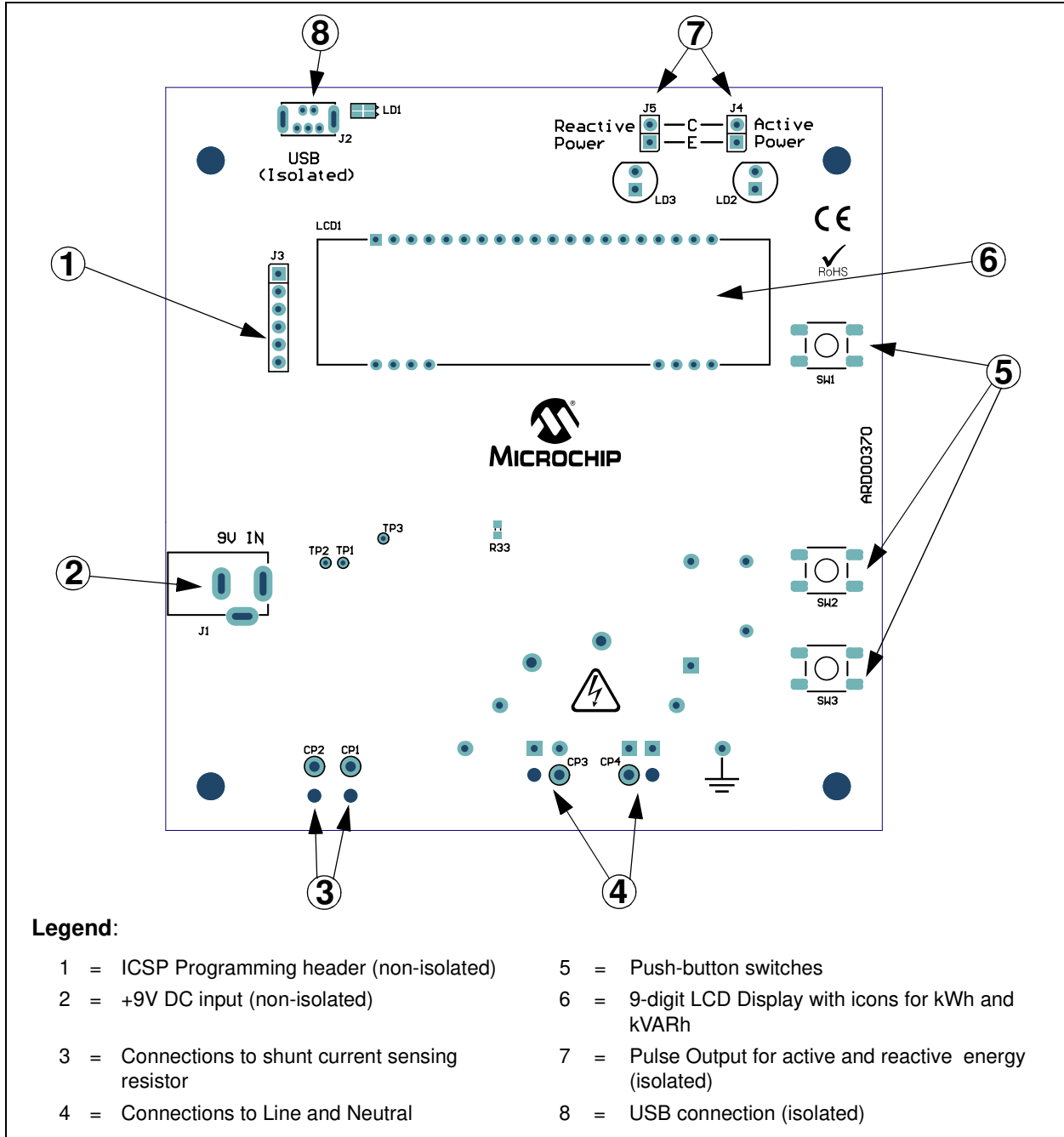

FIGURE 2-1: Top View – Hardware Components.

MCP6L2 and PIC18F66J93 Energy Meter Reference Design

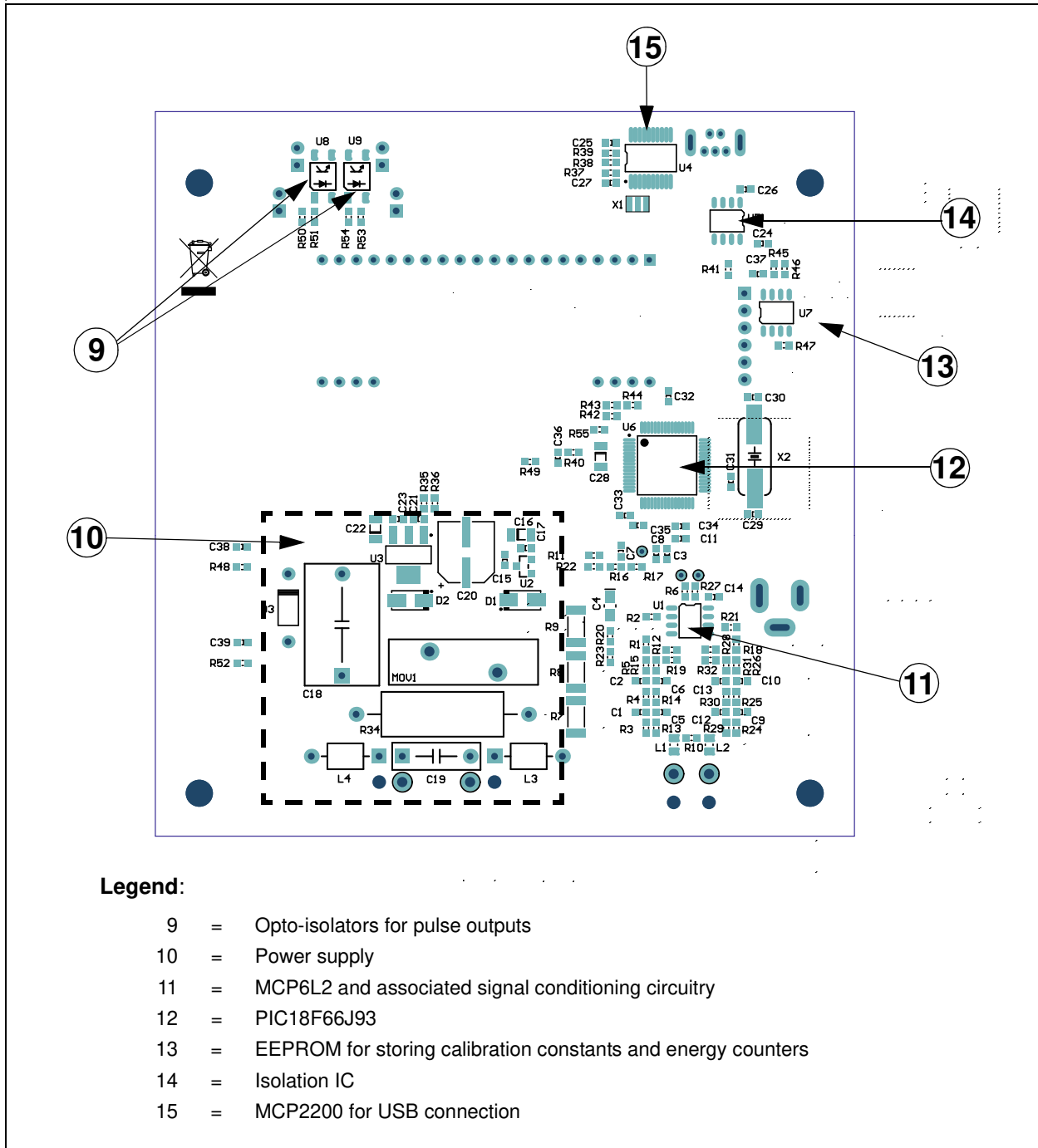

FIGURE 2-2: Bottom View – Hardware Components.

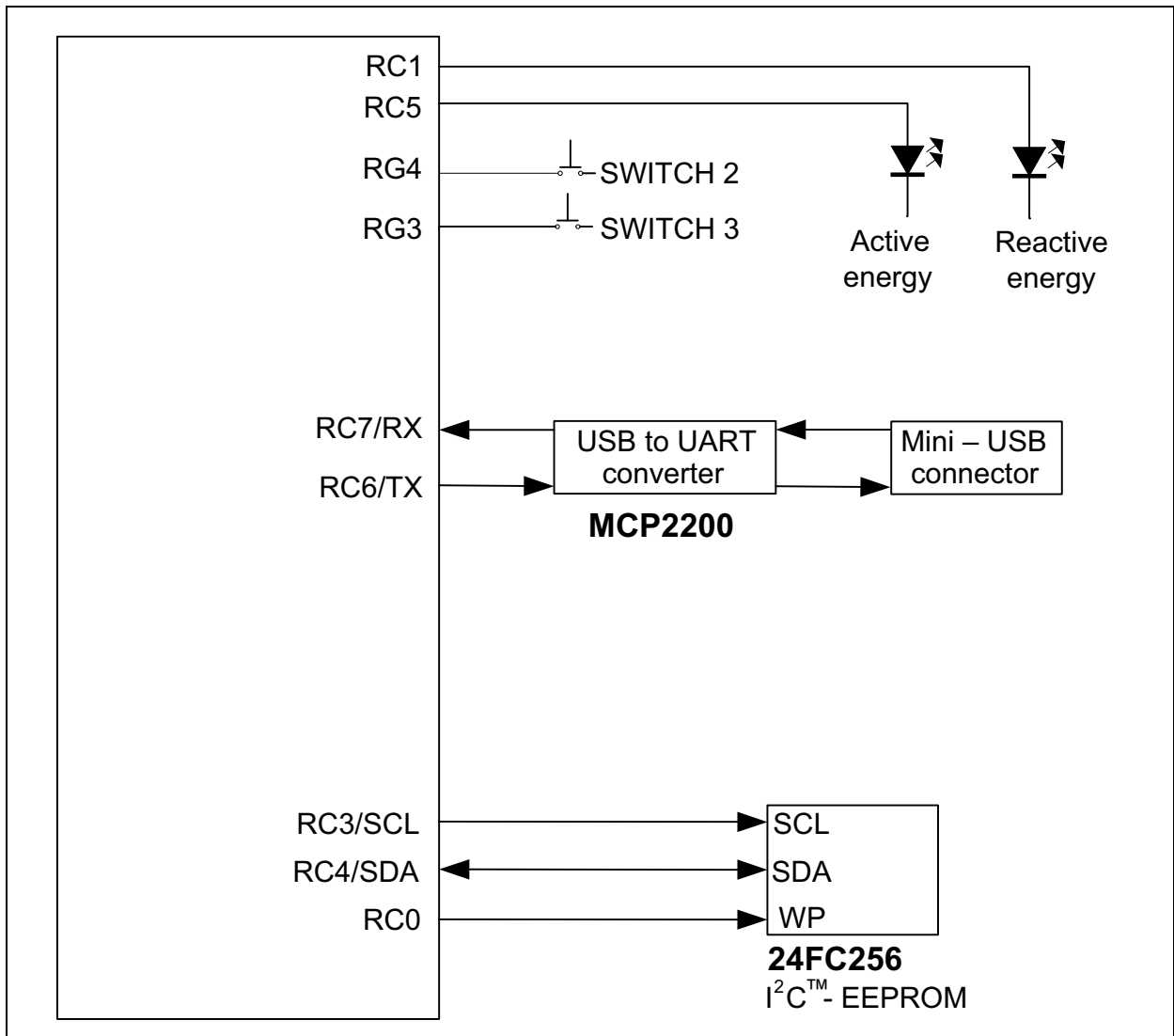

FIGURE 2-3: Digital Connections.

MCP6L2 and PIC18F66J93 Energy Meter Reference Design

2.2 INPUT AND ANALOG FRONT END

The MCP6L2 and PIC18F66J93 Energy Meter comes populated with components designed for 220V line voltage. The high voltage line and neutral connections are at the bottom of the main board. The 200 $\mu\Omega$ shunt sits on the high or line side of a two-wire system, and the meter employs a hot or "live" ground.

The neutral side of the two-wire system goes into a resistor divider on the voltage channel input, along with a DC offset added from V_{DD} . Anti-aliasing low-pass filters are included. The voltage channel uses three 100 k Ω resistors and one 820 Ω resistor to achieve a divider ratio of 366:1. For a line voltage of 220 V_{RMS} , the voltage channel input signal size will be 601 mV_{RMS} , with a DC offset of 1.65V.

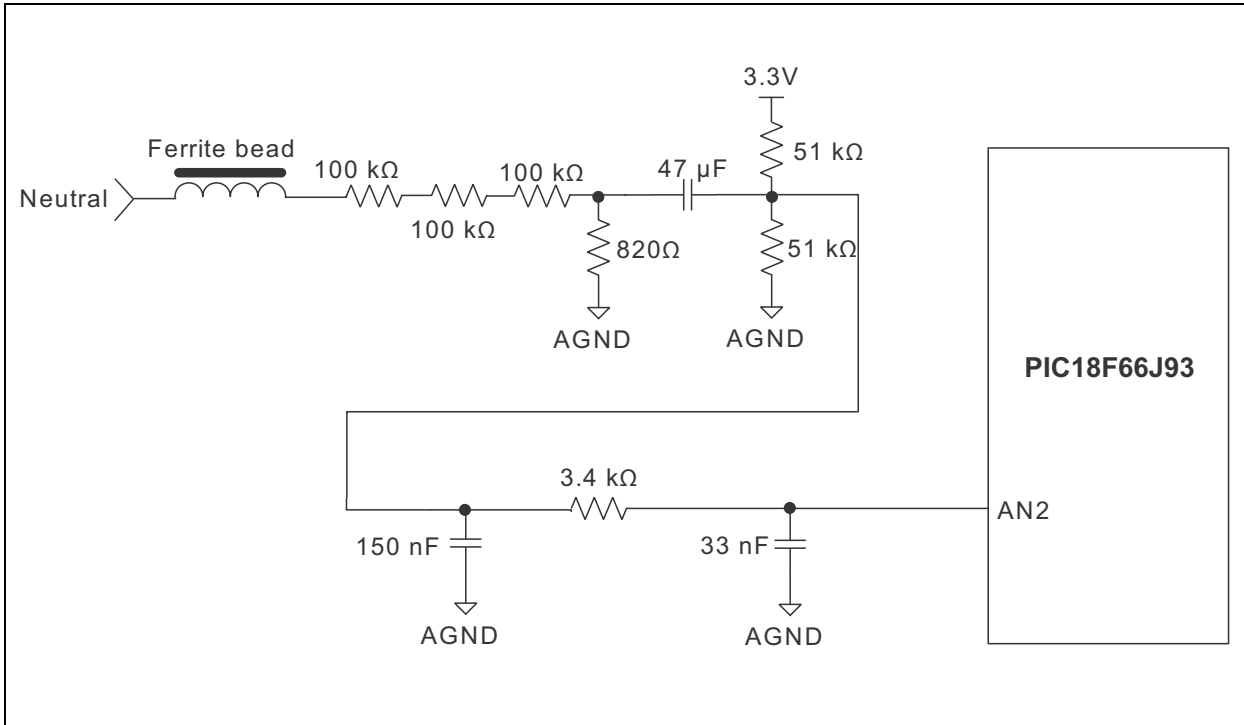

FIGURE 2-4: Analog Front End - Voltage Measurement.

To amplify the signal from the shunt, this energy meter design uses the two operational amplifiers from the MCP6L2 device to create two signal paths, with different gains: one for the low-current's range and one for the high-current's range, as shown in Figures 2-5 and 2-6:

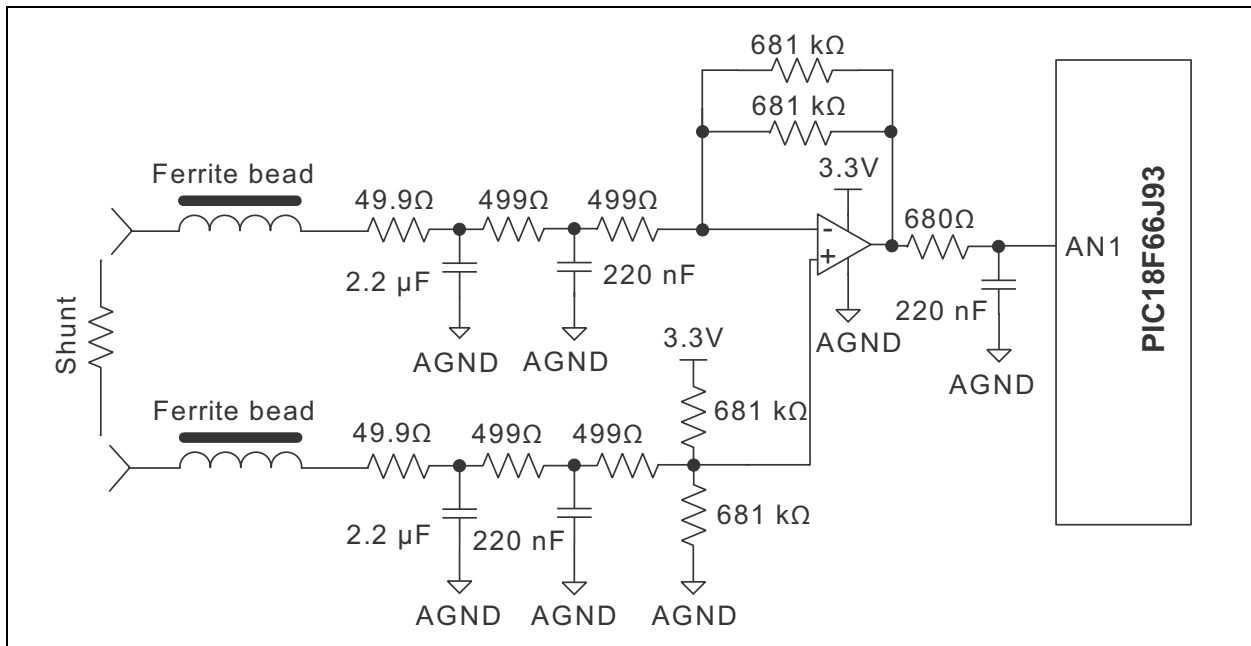

FIGURE 2-5: Analog Input Circuitry for Current Measurement, LOW-Current's Range.

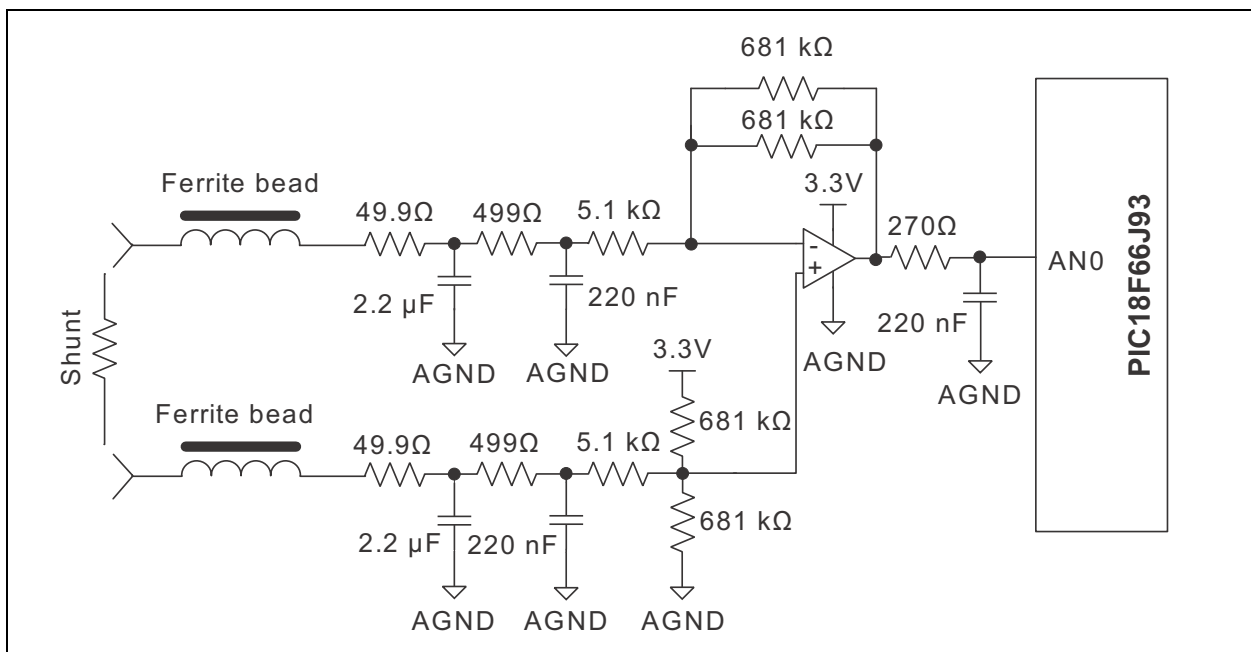

FIGURE 2-6: Analog Input Circuitry for Current Measurement, HIGH-Current's Range.

The low-current's range circuit (Figure 2-5) has a gain of 325 V/V. The high-current's range circuit (Figure 2-6) has a gain of 60 V/V. The firmware switches between the two gains with hysteresis between 4 and 5 A_{RMS} .

Note that all of the circuitry associated with the analog front-end is connected to the analog ground plane, AGND.

MCP6L2 and PIC18F66J93 Energy Meter Reference Design

2.3 POWER SUPPLY CIRCUIT

The capacitive power supply circuit for the MCP6L2 and PIC18F66J93 Energy Meter uses a half-wave rectified signal and two +3.3V voltage regulators. One Low-dropout (LDO) supplies the analog side, and the other supplies the digital circuitry of the meter. There is an option to use only one LDO, by populating the R33 resistor and removing the U2 LDO. This will result in a lower cost meter, at the price of a decrease in accuracy.

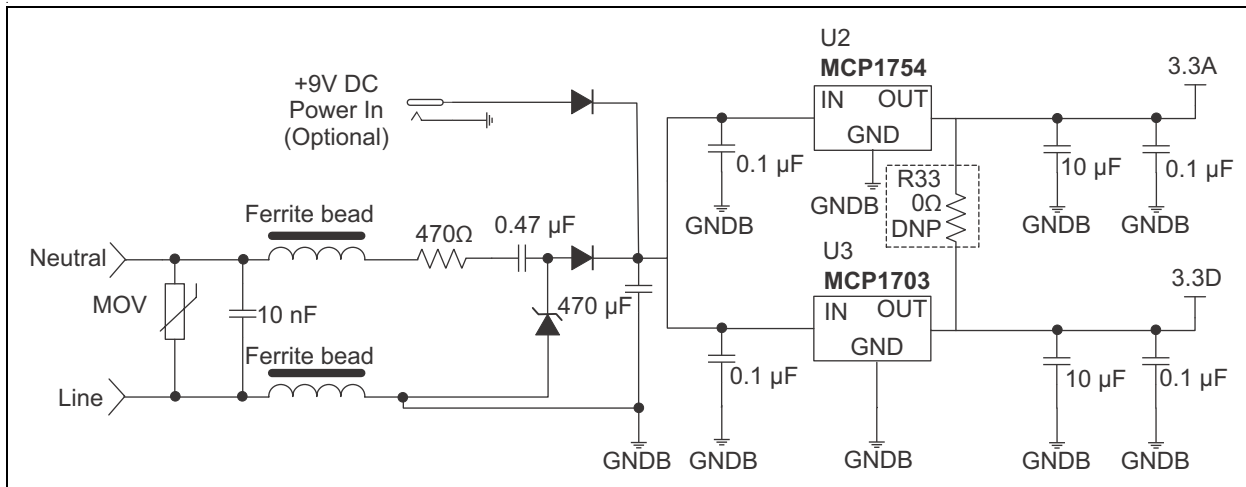

FIGURE 2-7: Power Supply Circuit.

Chapter 3. Calculation Engine and Register Description

3.1 COHERENT SAMPLING ALGORITHM

3.1.1 The Advantages of the Coherent Sampling in this Energy Metering Design

The outputs of an energy meter, power and RMS values are obtained by multiplying two AC signals, computing the average value and then multiplying it with a calibration gain. Ideally, these signals are sinusoids, with the frequency equal to the line frequency:

EQUATION 3-1:

$$S_1(t) = A_1 \cos(\omega t)$$

$$S_2(t) = A_2 \cos(\omega t + \phi)$$

The two signals (S_1 and S_2) can be the voltage and/or the current waveforms. The instantaneous power value is obtained by multiplication:

EQUATION 3-2:

$$P(t) = S_1(t) \times S_2(t) = \frac{A_1 \times A_2}{2} \times \cos(\phi) + \frac{A_1 \times A_2}{2} \times \cos(2\omega t + \phi)$$

The resultant signal has a continuous component and a sinusoidal component with a frequency equal to double the line frequency. Because the energy meter is computing the average power, only the continuous component is of interest, with the other requiring attenuation. If it is not properly attenuated, the indication of the energy meter will fluctuate in time. There are two methods to obtain efficient attenuation of the unwanted component: low-pass filtering and coherent sampling.

The instantaneous power signal can be applied to a low-pass filter with the cutoff frequency much lower than the double of the line frequency. If the energy meter must compute Active Power, Reactive Power, RMS Voltage, RMS Current (four instantaneous power computations, in total), it means that four low-pass filters must be applied.

In this particular energy meter design, with two current paths and gain switching controlled by the firmware, the problem is more complex with the low-pass filtering approach. This is because the low-pass filters have low-cutoff frequency, and consequently, high settling time. This affects the response of the meter outputs when the current gain is switched. In order to avoid this, the signals from the two current paths must be processed simultaneously, and low-pass filters must be applied on the instantaneous powers resulting from both paths. Therefore, three additional low-pass filters are required (for the instantaneous Active Power, Reactive Power and RMS Current on the other current channel). This means a total of seven low-pass filters are required for this energy meter design. Considering that the low-pass filter routines must be executed for each sample, the resulting processing time can be too long.

MCP6L2 and PIC18F66J93 Energy Meter Reference Design

The coherent sampling approach solves this issue by eliminating the low-pass filters. Coherent sampling refers to the situation when the sampling frequency is a fixed integer multiple of the line frequency. The unwanted sinusoidal component from the instantaneous power signal is attenuated under coherent sampling conditions, if the averaging is computed over a number of samples corresponding to an integer number of line cycles.

3.1.2 Coherent Sampling Algorithm

Coherent sampling implies a dependency between the sampling frequency and the line frequency. Because the line frequency is not fixed, the sampling frequency needs to be adjustable. In the MCP6L2 and PIC18F66J93 Energy Meter design, based on the microcontroller's internal successive approximation ADC (SAR ADC), the sampling period is controlled by a timer. At the beginning of the Interrupt Service Routine, the new timer value is set, and then the ADC samples are acquired and processed. The new timer value is computed based on the value of the line signal period.

In order to save hardware resources (timers), the line signal period is not measured directly in this design. Based on the amplitude of the acquired signal samples, the firmware detects the zero crossings on rising edges and tries to achieve a fixed integer number of samples between successive crossings, by adjusting the sampling period. The conditions for obtaining coherent sampling implemented in the firmware are:

- The number of samples between zero crossings must have a certain value (64 samples per line cycle in this design)
- The difference between the first sample after zero crossing and the corresponding sample from the previous line period, must be within certain limits (for more accurate locking on the line frequency).

A graphical representation of these conditions is shown in [Figure 3-1](#).

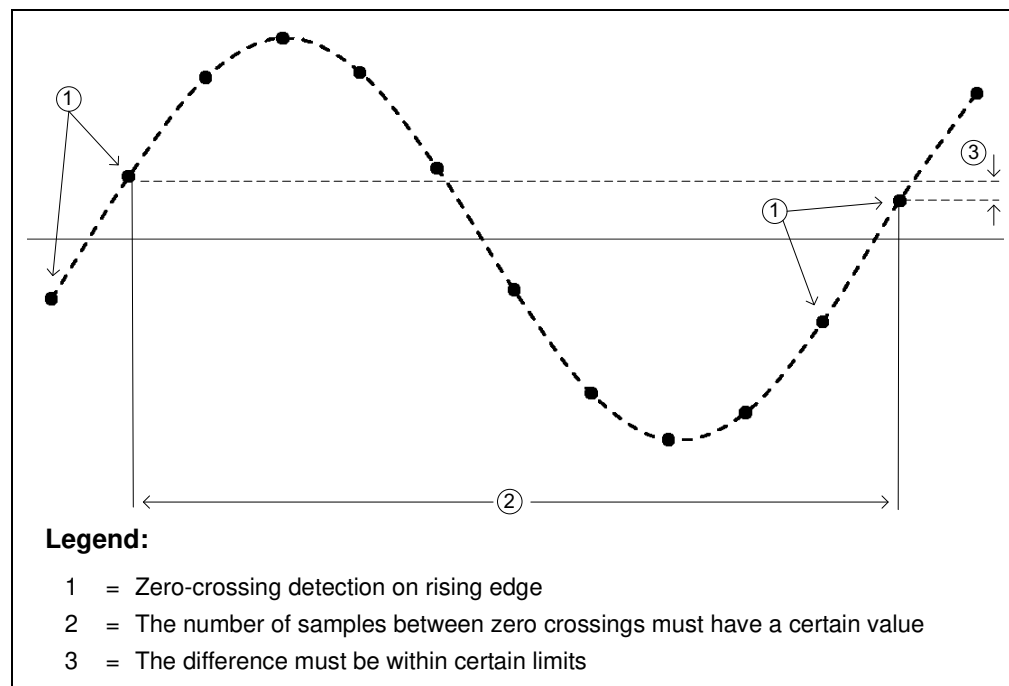

FIGURE 3-1: Conditions for Obtaining Coherent Sampling Implemented in the Firmware.

These conditions are checked after every zero crossing on rising edge. If they are not met, then the corrections are applied to the sampling period.

Calculation Engine and Register Description

The zero-crossing detection is done on the voltage channel, because it has much lower dynamic range than the current channel. To increase immunity to noise and distortions (harmonics), the acquired voltage samples are passed through a low-pass filter with a cutoff frequency lower than the line frequency, before being processed for zero-crossing detection.

3.2 CALCULATION ENGINE SIGNAL FLOW SUMMARY

RMS voltage, RMS current, Active Power, Reactive Power, Apparent Power and calibration output pulses are calculated through the process described in Figure 3-2. The calibration registers for each calculation are shown as well as the output registers.

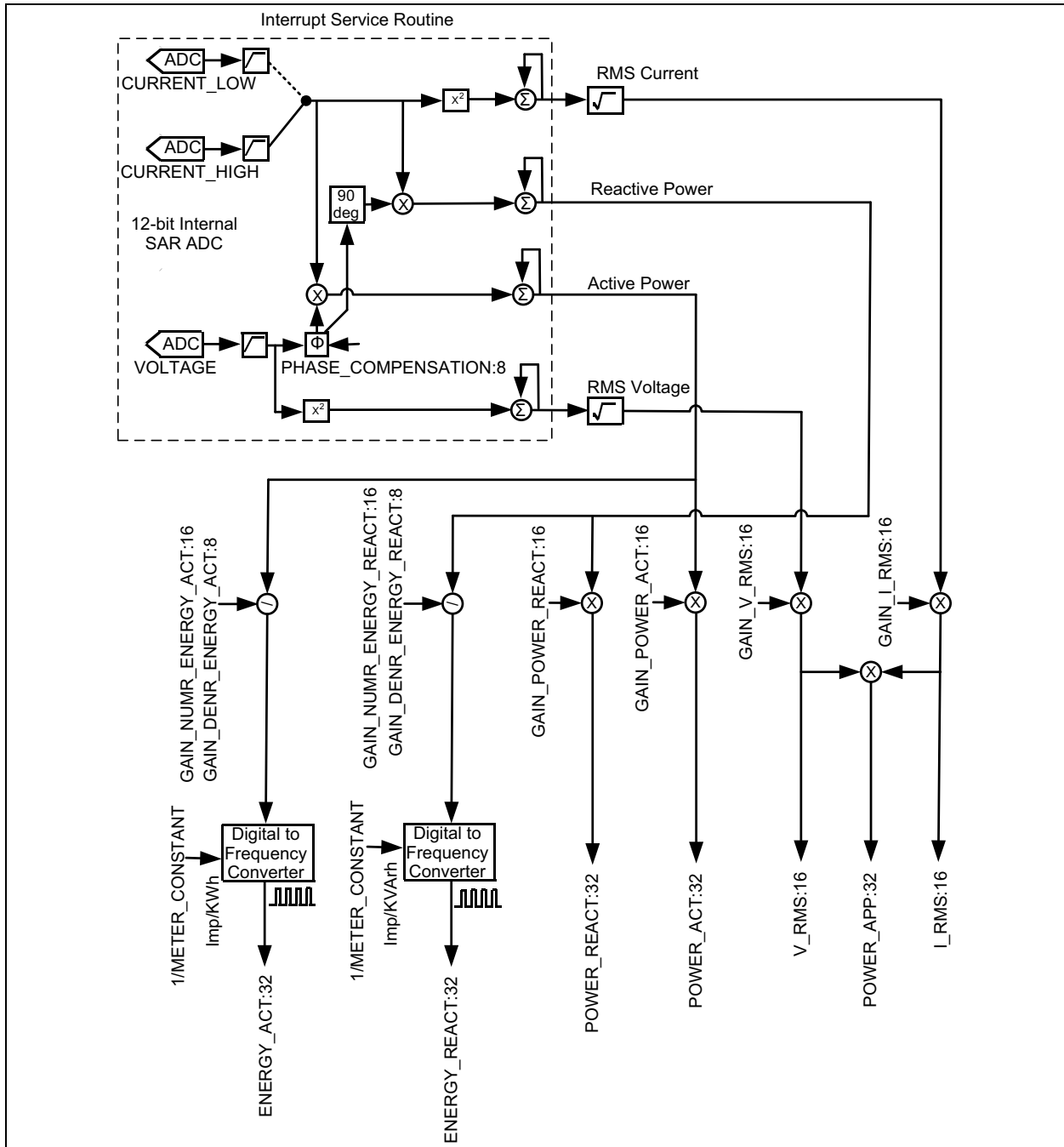

FIGURE 3-2: MCP6L2 and PIC18F66J93 Calculation Engine Signal Flow.

MCP6L2 and PIC18F66J93 Energy Meter Reference Design

3.3 COMPLETE REGISTER LIST

TABLE 3-1: INTERNAL REGISTER SUMMARY

Address	Register Name	Bits	R/W	Description
0x000	METER_VERSION_ID	8	R	Hardware and firmware version identification register
0x001	METER_STATUS	8	R	Contains information regarding the operational status of the meter
0x002	CAL_CONTROL	8	R/W	Configuration register for calibration control
0x003	RAW_I_RMS	16	R	Raw RMS value of the current channel
0x005	I_RMS	16	R	RMS value of the current channel, post calibration
0x007	RAW_V_RMS	16	R	Raw RMS value of the voltage channel
0x009	V_RMS	16	R	RMS value of the voltage channel, post calibration
0x00B	FREQUENCY	16	R	Line frequency indication
0x00D	POWER_ACT	32	R	Active Power indication
0x011	POWER_REACT	32	R	Reactive Power indication
0x015	POWER_APP	32	R	Apparent Power indication
0x019	POWER_FACTOR	16	R	Power factor indication
0x01B	PHASE_COMPENSATION	8	R	Phase delay between voltage and current channels
0x01C	GAIN_I_RMS	16	R	Gain adjustment for current channel RMS
0x01E	GAIN_POWER_ACT	16	R	Active Power Gain adjust
0x020	GAIN_POWER_REACT	16	R	Reactive Power Gain adjust
0x022	GAIN_NUMR_ENERGY_ACT	16	R	Active Power Pulse Output correction factor
0x024	GAIN_DENR_ENERGY_ACT	8	R	Active Power Pulse Output correction factor
0x025	GAIN_NUMR_ENERGY_REACT	16	R	Reactive Power Pulse Output correction factor
0x027	GAIN_DENR_ENERGY_REACT	8	R	Reactive Power Pulse Output correction factor
0x028	PHASE_COMPENSATION_LOW	8	R/W	Phase-delay between voltage and low region current channels
0x029	PHASE_COMPENSATION_HIGH	8	R/W	Phase-delay between voltage and high region current channels
0x02A	GAIN_V_RMS	16	R/W	Gain adjustment for voltage RMS
0x02C	GAIN_I_RMS_LOW	16	R/W	Gain adjustment for low region current RMS
0x02E	GAIN_I_RMS_HIGH	16	R/W	Gain adjustment for high region current RMS
0x030	GAIN_POWER_ACT_LOW	16	R/W	Low-region Active Power gain adjust
0x032	GAIN_POWER_ACT_HIGH	16	R/W	High-region Active Power gain adjust
0x034	GAIN_NUMR_ENERGY_ACT_LOW	16	R/W	Low-region Active Power Pulse Output correction factor
0x036	GAIN_NUMR_ENERGY_ACT_HIGH	16	R/W	High-region Active Power Pulse Output correction factor
0x038	GAIN_DENR_ENERGY_ACT_LOW	8	R/W	Low-region Active Power Pulse Output correction factor
0x039	GAIN_DENR_ENERGY_ACT_HIGH	8	R/W	High-region Active Power Pulse Output correction factor
0x03A	GAIN_POWER_REACT_LOW	16	R/W	Low-region Reactive Power gain adjust
0x03C	GAIN_POWER_REACT_HIGH	16	R/W	High-region Reactive Power gain adjust
0x03E	GAIN_NUMR_ENERGY_REACT_LOW	16	R/W	Low-region Reactive Power Pulse Output correction factor

Calculation Engine and Register Description

TABLE 3-1: INTERNAL REGISTER SUMMARY (CONTINUED)

Address	Register Name	Bits	R/W	Description
0x040	GAIN_NUMR_ENERGY_REACT_HIGH	16	R/W	High-region Reactive Power Pulse Output correction factor
0x042	GAIN_DENR_ENERGY_REACT_LOW	8	R/W	Low-region Reactive Power Pulse Output correction factor
0x043	GAIN_DENR_ENERGY_REACT_HIGH	8	R/W	High-region Reactive Power Pulse Output correction factor
0x044	METER_CONSTANT	16	R/W	Meter Constant in imp/kWh
0x046	PULSE_WIDTH	8	R/W	Defines CF pulse width in milliseconds
0x047	NO_LOAD_THRESHOLD_I_RMS	8	R/W	Bellow this Current RMS indication, energy accumulation is disabled
0x048	LINE_CYC	8	R/W	It is "n" from the formula: Computation cycle = 2 ⁿ number of line cycles
0x100	ENERGY_ACT	32	R/W	Active Energy Counter
0x104	ENERGY_REACT	32	R/W	Reactive Energy Counter

3.4 METER_VERSION_ID

Name	Bits	Address	Cof.
METER_VERSION_ID	8	0x000	R

This register contains a constant that is hard-coded in the firmware, giving information regarding the hardware and firmware version running on the energy meter.

3.5 METER_STATUS

Name	Bits	Address	Cof.
METER_STATUS	8	0x001	R

The register contains information regarding the operational status of the energy meter.

REGISTER 3-1: METER_STATUS REGISTER

U-0	U-0	U-0	U-0	U-0	U-0	U-0	R
—	—	—	—	—	—	—	CURRENT_REGION
bit 7							bit 0

Legend:

R = Readable bit	W = Writable bit	U = Unimplemented bit, read as '0'
-n = Value at POR	'1' = Bit is set	'0' = Bit is cleared x = Bit is unknown

bit 7-1 **Unimplemented:** Read as '0'

bit 0 **CURRENT_REGION:** Indicates the selected current region

 1 = High Current Region

 0 = Low Current Region

MCP6L2 and PIC18F66J93 Energy Meter Reference Design

3.6 CAL_CONTROL

Name	Bits	Address	Cof
CAL_CONTROL	8	0x002	R/W

This register controls the calibration process.

REGISTER 3-2: CAL_CONTROL REGISTER

U-0	U-0	U-0	R-0	R/W-0	R/W-0	U-0	R/W-0
—	—	—	AUTOCAL_FIRST _LINE_CYCLE	CURRENT_REGION _SELECTED	FORCE_CURRENT _REGION	—	CAL_MODE
bit 7							bit 0

Legend:

R = Readable bit W = Writable bit U = Unimplemented bit, read as '0'
 -n = Value at POR '1' = Bit is set '0' = Bit is cleared x = Bit is unknown

- bit 7-5 **Unimplemented:** Read as '0'
- bit 4 **AUTOCAL_FIRST_LINE_CYCLE:** Flag used in the auto-calibration routine.
 - 1 = The actual line cycle is the first after the current region has been changed in the auto-calibration routine.
 - 0 = The actual line cycle is not the first after the current region has been changed in the auto-calibration routine.
- bit 3 **CURRENT_REGION_SELECTED:** Current region set by the external device via UART, during the calibration procedure
 - 1 = Low Current Region
 - 0 = High Current Region
- bit 2 **FORCE_CURRENT_REGION:** This bit is set by the external device via UART, before the calibration procedure.
 - 1 = Automatic current region selection is bypassed. The current region is set by the "CURRENT_REGION_SELECTED" bit.
 - 0 = The current region is set automatically, based on current RMS indication.
- bit 1 **Unimplemented:** Read as '0'
- bit 0 **CAL_MODE:** Activates the auto-calibration procedure.
 - 1 = Auto-calibration procedure has been activated.
 - 0 = Auto-calibration procedure is not enabled.

3.7 RAW_I_RMS

Name	Bits	Address	Cof
RAW2_I_RMS	16	0x003	R

This register is the raw current RMS value, before the multiplication with the calibration register GAIN_I_RMS.

Calculation Engine and Register Description

3.8 I_RMS

Name	Bits	Address	Cof
I_RMS	16	0x005	R

This register is the current RMS indication, in amperes, after the multiplication with the calibration register GAIN_I_RMS. The decimal point is placed after three digits, for low-current region, or two digits, for high-current region. For example: if the meter is in the low region and the read value is I_RMS = 5000 (in decimal), it means that the current is 5.000A. But if the same value is read when the meter is in the high-current region, it means that the current is 50.00A .

3.9 RAW_V_RMS

Name	Bits	Address	Cof
RAW_V_RMS	16	0x007	R

This register is the raw voltage RMS value, before the multiplication with the calibration register GAIN_V_RMS.

3.10 V_RMS

Name	Bits	Address	Cof
V_RMS	16	0x009	R

This register is the voltage RMS indication, in volts, after the multiplication with the calibration register GAIN_V_RMS. The decimal point is placed after the first digit. For example: a read value of V_RMS = 2200 means 220.0V.

3.11 FREQUENCY

Name	Bits	Address	Cof
FREQUENCY	16	0x00B	R

This register is the line frequency indication, in hertz. The decimal point is placed after three digits. For example: a read value of FREQUENCY = 50000 means 50.000 Hz.

3.12 POWER_ACT

Name	Bits	Address	Cof
POWER_ACT	32	0x00D	R

This register is the active power indication, in watts. The decimal point is placed after five digits for low-current region or four digits for high-current region. For example: if the meter is in the low region and the read value is POWER_ACT = 110000000 (in decimal), it means that the active power is 1100.00000W. If the same value is read when the meter is in the high-current region, it means that the active power is 11000.0000W.

MCP6L2 and PIC18F66J93 Energy Meter Reference Design

3.13 POWER_REACT

Name	Bits	Address	Cof
POWER_REACT	32	0x011	R

This register is the reactive power indication, in VAR. The decimal point is placed after five digits, for low-current region, or four digits, for high-current region. For example: if the meter is in the low region and the read value is POWER_REACT = 110000000 (in decimal), it means that the active power is 1100.00000 VAR. If the same value is read when the meter is in the high-current region, it means that the active power is 11000.0000 VAR.

3.14 POWER_APP

Name	Bits	Address	Cof
POWER_APP	32	0x015	R

This register is the apparent power indication, in VA. The decimal point is placed after five digits, for low-current region, or four digits, for high-current region. For example: if the meter is in the low region and the read value is POWER_APP = 110000000 (in decimal), it means that the active power is 1100.00000 VA. If the same value is read when the meter is in the high-current region, it means that the active power is 11000.0000 VA.

3.15 POWER_FACTOR

Name	Bits	Address	Cof
POWER_FACTOR	16	0x019	R

This register is the power factor indication. The power factor value is obtained by dividing the register value to 65535. For example: a read value of POWER_FACTOR = 32767 means that the power factor is 0.5.

3.16 PHASE_COMPENSATION

Name	Bits	Address	Cof
PHASE_COMPENSATION	8	0x01B	R

This register contains the phase compensation value between the voltage and the current channels, used by the metering engine at the moment of reading. It is a copy of one of the calibration registers: PHASE_COMPENSATION_LOW or PHASE_COMPENSATION_HIGH, depending on the actual current region.

For more information related to phase compensation implementation in firmware, refer to **Chapter 2.3.2.3** from “PIC18F87J72 Single-Phase Energy Meter Calibration User's Guide” (DS51964).

Calculation Engine and Register Description

3.17 GAIN_I_RMS

Name	Bits	Address	Cof
GAIN_I_RMS	16	0x01C	R

This register contains the gain value for the current RMS indication, used by the metering engine at the moment of reading. It is a copy of one of the calibration registers: GAIN_I_RMS_LOW or GAIN_I_RMS_HIGH, depending on the actual current region.

3.18 GAIN_POWER_ACT

Name	Bits	Address	Cof
GAIN_POWER_ACT	16	0x01E	R

This register contains the gain value for the active power indication, used by the metering engine at the moment of reading. It is a copy of one of the calibration registers: GAIN_POWER_ACT_LOW or GAIN_POWER_ACT_HIGH, depending on the actual current region.

3.19 GAIN_POWER_REACT

Name	Bits	Address	Cof
GAIN_POWER_REACT	16	0x020	R

This register contains the gain value for the reactive power indication, used by the metering engine at the moment of reading. It is a copy of one of the calibration registers: GAIN_POWER_REACT_LOW or GAIN_POWER_REACT_HIGH, depending on the actual current region.

3.20 GAIN_NUMR_ENERGY_ACT

Name	Bits	Address	Cof
GAIN_NUMR_ENERGY_ACT	16	0x022	R

This register contains the active energy gain value necessary to produce the specified number of impulses per kilowatt-hour (the meter constant), used by the metering engine at the moment of reading. It is a copy of one of the calibration registers: GAIN_NUMR_ENERGY_ACT_LOW or GAIN_NUMR_ENERGY_ACT_HIGH, depending on the actual current region.

MCP6L2 and PIC18F66J93 Energy Meter Reference Design

3.21 GAIN_DENR_ENERGY_ACT

Name	Bits	Address	Cof
GAIN_DENR_ENERGY_ACT	8	0x024	R

This register contains the number of left bit shifts for the raw active power, used by the metering engine at the moment of reading. It is a copy of one of the calibration registers: GAIN_DENR_ENERGY_ACT_LOW or GAIN_DENR_ENERGY_ACT_HIGH, depending on the actual current region.

3.22 GAIN_NUMR_ENERGY_REACT

Name	Bits	Address	Cof
GAIN_NUMR_ENERGY_REACT	16	0x025	R

This register contains the reactive energy gain value necessary to produce the specified number of impulses per kVAh (the meter constant), used by the metering engine at the moment of reading. It is a copy of one of the calibration registers: GAIN_NUMR_ENERGY_REACT_LOW or GAIN_NUMR_ENERGY_REACT_HIGH, depending on the actual current region.

3.23 GAIN_DENR_ENERGY_REACT

Name	Bits	Address	Cof
GAIN_DENR_ENERGY_REACT	8	0x027	R

This register contains the number of left bit shifts for the raw reactive power, used by the metering engine at the moment of reading. It is a copy of one of the calibration registers: GAIN_DENR_ENERGY_REACT_LOW or GAIN_DENR_ENERGY_REACT_HIGH, depending on the actual current region.

3.24 PHASE_COMPENSATION_LOW

Name	Bits	Address	Cof
PHASE_COMPENSATION_LOW	8	0x028	R/W

This calibration register contains the phase compensation value between the voltage and the low-current region channel.

For more information related to phase compensation implementation in firmware please refer to **Chapter 2.3.2.3** from “PIC18F87J72 Single-Phase Energy Meter Calibration User's Guide” (DS51964).

Calculation Engine and Register Description

3.25 PHASE_COMPENSATION_HIGH

Name	Bits	Address	Cof
PHASE_COMPENSATION_HIGH	8	0x029	R/W

This calibration register contains the phase compensation value between the voltage and the high-current region channel.

For more information related to phase compensation implementation in firmware please refer to **Chapter 2.3.2.3** from “*PIC18F87J72 Single-Phase Energy Meter Calibration User's Guide*” (DS51964).

3.26 GAIN_V_RMS

Name	Bits	Address	Cof
GAIN_V_RMS	16	0x02A	R/W

This calibration register contains the gain value for the voltage RMS indication.

3.27 GAIN_I_RMS_LOW

Name	Bits	Address	Cof
GAIN_I_RMS_LOW	16	0x02C	R/W

This calibration register contains the gain value for the current RMS indication in the low-current region.

3.28 GAIN_I_RMS_HIGH

Name	Bits	Address	Cof
GAIN_I_RMS_HIGH	16	0x02E	R/W

This calibration register contains the gain value for the current RMS indication in the high-current region.

3.29 GAIN_POWER_ACT_LOW

Name	Bits	Address	Cof
GAIN_POWER_ACT_LOW	16	0x030	R/W

This calibration register contains the gain value for the active power indication in the low-current region.

MCP6L2 and PIC18F66J93 Energy Meter Reference Design

3.30 GAIN_POWER_ACT_HIGH

Name	Bits	Address	Cof
GAIN_POWER_ACT_HIGH	16	0x032	R/W

This calibration register contains the gain value for the active power indication in the high-current region.

3.31 GAIN_NUMR_ENERGY_ACT_LOW

Name	Bits	Address	Cof
GAIN_NUMR_ENERGY_ACT_LOW	16	0x034	R/W

This calibration register contains the active energy gain value necessary to produce the specified number of impulses per kWh (the meter constant) in the low-current region.

3.32 GAIN_NUMR_ENERGY_ACT_HIGH

Name	Bits	Address	Cof
GAIN_NUMR_ENERGY_ACT_HIGH	16	0x036	R/W

This calibration register contains the active energy gain value necessary to produce the specified number of impulses per kWh (the meter constant) in the high-current region.

3.33 GAIN_DENR_ENERGY_ACT_LOW

Name	Bits	Address	Cof
GAIN_DENR_ENERGY_ACT_LOW	8	0x038	R/W

This calibration register contains the number of left bit shifts for the raw active power in the low-current region.

3.34 GAIN_DENR_ENERGY_ACT_HIGH

Name	Bits	Address	Cof
GAIN_DENR_ENERGY_ACT_HIGH	8	0x039	R/W

This calibration register contains the number of left bit shifts for the raw active power in the high-current region.

3.35 GAIN_POWER_REACT_LOW

Name	Bits	Address	Cof
GAIN_POWER_REACT_LOW	16	0x03A	R/W

This calibration register contains the gain value for the reactive power indication in the low-current region.

Calculation Engine and Register Description

3.36 GAIN_POWER_REACT_HIGH

Name	Bits	Address	Cof
GAIN_POWER_REACT_HIGH	16	0x03C	R/W

This calibration register contains the gain value for the reactive power indication in the high-current region.

3.37 GAIN_NUMR_ENERGY_REACT_LOW

Name	Bits	Address	Cof
GAIN_NUMR_ENERGY_REACT_LOW	16	0x03E	R/W

This calibration register contains the reactive energy gain value necessary to produce the specified number of impulses per kVAh (the meter constant) in the low-current region.

3.38 GAIN_NUMR_ENERGY_REACT_HIGH

Name	Bits	Address	Cof
GAIN_NUMR_ENERGY_REACT_HIGH	16	0x040	R/W

This calibration register contains the reactive energy gain value necessary to produce the specified number of impulses per kVAh (the meter constant) in the high-current region.

3.39 GAIN_DENR_ENERGY_REACT_LOW

Name	Bits	Address	Cof
GAIN_DENR_ENERGY_REACT_LOW	8	0x042	R/W

This calibration register contains the number of left bit shifts for the raw reactive power in the low-current region.

3.40 GAIN_DENR_ENERGY_REACT_HIGH

Name	Bits	Address	Cof
GAIN_DENR_ENERGY_REACT_HIGH	8	0x043	R/W

This calibration register contains the number of left bit shifts for the raw reactive power in the low-current region.

MCP6L2 and PIC18F66J93 Energy Meter Reference Design

3.41 METER_CONSTANT

Name	Bits	Address	Cof
METER_CONSTANT	16	0x044	R/W

This register contains the meter constant in imp/kWh. It must be a multiple of 100.

3.42 PULSE_WIDTH

Name	Bits	Address	Cof
PULSE_WIDTH	8	0x046	R/W

This register contains the width of the active/reactive energy pulse in milliseconds. The maximum pulse width that can be set in the existing firmware release is 65 milliseconds. If higher values are required, then the corresponding code portion in the firmware must be modified.

3.43 NO_LOAD_THRESHOLD_I_RMS

Name	Bits	Address	Cof
NO_LOAD_THRESHOLD_I_RMS	8	0x047	R/W

This register contains the current RMS indication (I_RMS value) in the low-current region below which the energy accumulation is disabled.

3.44 LINE_CYC

Name	Bits	Address	Cof
LINE_CYC	8	0x048	R/W

This register contains the value of "n" from the formula:

EQUATION 3-3:

$$Computation_cycle_duration = 2^n \times line_cycle_duration$$

The computation cycle contains a number of 2^n line cycles. The indication registers are updated every computation cycle. The value of LINE_CYC register sets the update rate of the indication registers.

In this software release LINE_CYC = 4. The energy meter was designed for 50 Hz systems, so a line cycle has a period of 20 milliseconds. It results in a computation cycle of :

$$Computation_cycle_duration = 2^4 \times 20 = 320 \text{ milliseconds}$$

Calculation Engine and Register Description

3.45 ENERGY_ACT

Name	Bits	Address	Cof
ENERGY_ACT	32	0x100	R/W

This energy counter register contains the accumulated active energy in kWh. The decimal point is after two digits. For example: an indication of ENERGY_ACT = 1234 means that the value of the accumulated active energy is 12.34 kWh.

3.46 ENERGY_REACT

Name	Bits	Address	Cof
ENERGY_REACT	32	0x104	R/W

This energy counter register contains the accumulated reactive energy in kVArh. The decimal point is after two digits. For example: an indication of ENERGY_REACT = 1234 means that the value of the accumulated active energy is 12.34 kVArh.

MCP6L2 and PIC18F66J93 Energy Meter Reference Design

NOTES:

Chapter 4. Communication Protocol

4.1 PROTOCOL

The UART of the PIC Microcontroller is used to communicate with the meter. In addition to the reading and writing of the registers, there are also dedicated commands for clearing, loading and storing calibration registers to Flash. The first byte UART data is an ASCII character that represents the command, and each command has a specific protocol. Each command ends with the ASCII character “X”.

4.1.1 Command Description

The first byte of the data (byte 0) is an ASCII character E, L, S, W, R, C or A.

- E – Request for Echo Response to which meter responds with “Q” as acknowledgment
- L – Load Calibration Registers from Flash (LOAD)
- S – Store Calibration Registers (STORE)
- W – Write Bytes (WRITE)
- R – Read Bytes (READ)
- C – Load Default Calibration Values
- A – Run Auto-calibration Routine

The last data byte is always an ‘X’ character. All commands will result in the same command being returned. The exception is the ‘R’ (READ) command which will return the additional data in lieu of the number of bytes.

4.1.1.1 “E” ECHO: - TO DETECT THE METER CONNECTION

Example: ‘EX’.

Returns: ‘QX’

4.1.1.2 “L” LOAD: LOAD CALIBRATION REGISTERS FROM FLASH

Example: ‘LX’.

Returns: ‘LX’.

This command is used to verify that the calibration values were actually written into Flash (or EEPROM). When the software executes an ‘SX’ command, it should verify that the values were stored by issuing an ‘LX’ command and then reading the calibration values with an ‘R’ command.

4.1.1.3 “S” STORE: STORE CALIBRATION REGISTERS INTO FLASH

The Store command writes all the calibration values to the internal EEPROM, and this function takes some time. During that time, the meter is not functional. The Store command should only be used after calibrating the meter, not while it is in actual use.

Example: ‘SX’.

Returns: ‘SX’.

MCP6L2 and PIC18F66J93 Energy Meter Reference Design

4.1.1.4 “W” WRITE: WRITE STARTING AT SPECIFIED ADDRESS

Write specified bytes.

Example: 'W030000102030405060708090A0B0C0D0E0FX'.

Returns: 'W030000102030405060708090A0B0C0D0E0FX'.

Note: If the number of data characters is odd, the last character (the one just prior to the 'X') will be ignored.

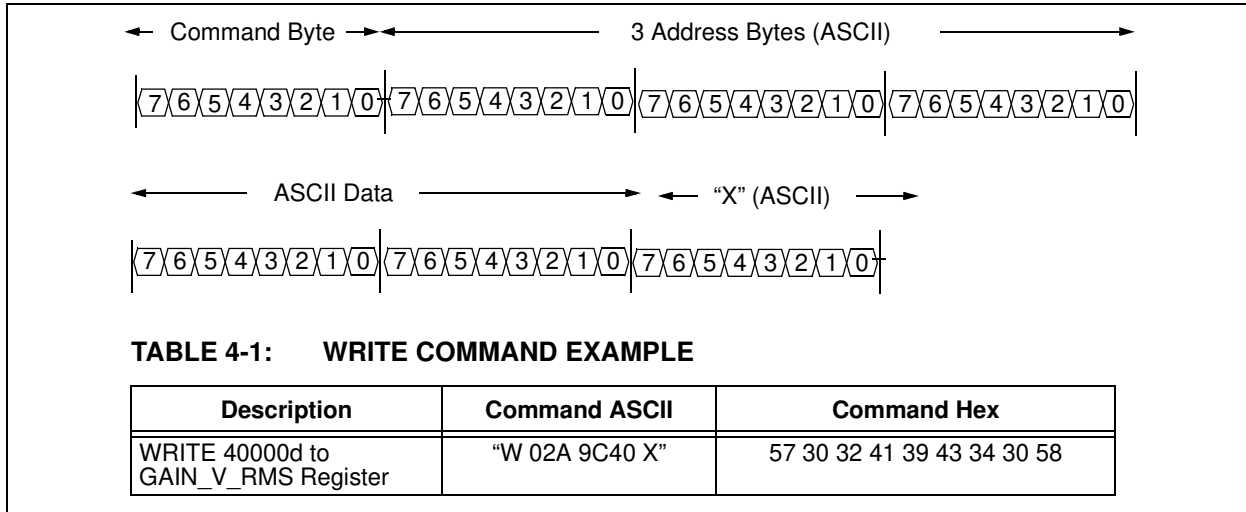

FIGURE 4-1: WRITE Command Protocol.

4.1.1.5 “R” READ: READ STARTING AT SPECIFIED ADDRESS

Example: 'R03010X' (read 16 bytes starting at address 30h).

Returns: 'R030000102030405060708090A0B0C0D0E0FX'.

Note: For 16 bytes, there are 32 ASCII characters returned, or two characters per byte.

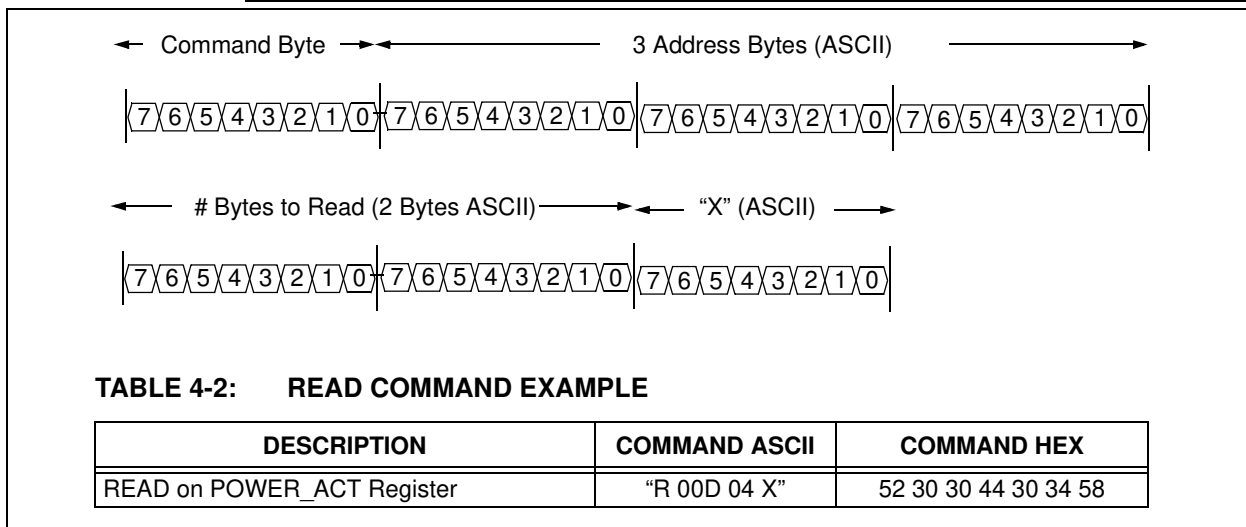

FIGURE 4-2: Read Command Protocol.

4.1.1.6 "A" AUTOCALIBRATION: RUN AUTO-CALIBRATION ROUTINE

Example: "AX"

Returns: "DX" or "BX"

This command enables the auto-calibration routine only if it is present in the firmware and returns "DX". If not, it returns "BX", indicating that the auto-calibration routine is not present in the firmware (the statement `#define AUTOCALIBRATION_ENABLE` is missing).

MCP6L2 and PIC18F66J93 Energy Meter Reference Design

NOTES:

Chapter 5. Microchip Energy Meter Software

5.1 OVERVIEW

The Microchip Energy Meter Software is a Graphical User Interface (GUI) that runs on a PC. It enables the meter to be monitored, debugged and calibrated during development phase.

5.2 THE MAIN SCREEN

The main screen contains four tabs:

- **Energy Meter:** This tab contains the instantaneous meter output display and a debug window, which enables access to all the internal registers of the meter.
- **Closed Loop Calibration:** This tab contains a calibration tool for closed loop calibration.
- **Open Loop Calibration:** This tab contains a calibration tool for open loop calibration.
- **Auto Calibration:** This tab contains an interface for auto calibration.

The calibration procedures are presented in detail in [Chapter 6. “Energy Meter Calibration”](#).

The COM port selection on the top of the window is used to select a serial port or a serial port emulator (the energy meter must be connected to the PC via the USB interface and powered up).

The status of the meter connection to the computer is displayed on the top of the window (see [Figure 5-1](#)). If connected, this status displays the text “Meter Detected” in green; when disconnected, it changes the status to “Meter Disconnected”, in red. The status is present across all tabs.

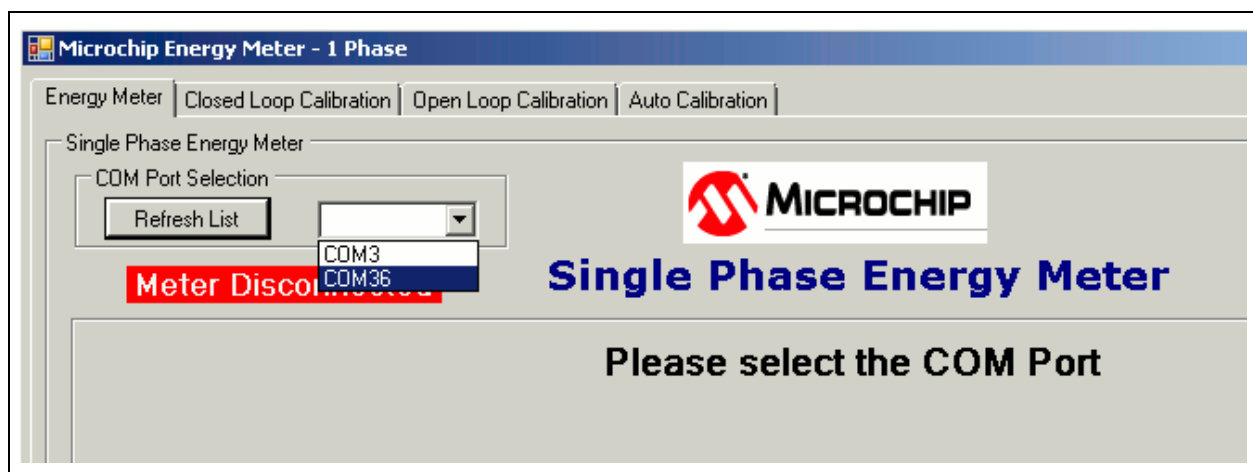

FIGURE 5-1: Energy Meter GUI – COM Port Selection.

MCP6L2 and PIC18F66J93 Energy Meter Reference Design

The tool has a feature to display the instantaneous parameters from the meter, updated in real time (see Figure 5-2). The “Instantaneous Parameters” field contains the recent meter output parameters: RMS Voltage, RMS Current, Line Frequency, Active Power, Reactive Power, Apparent Power and Power Factor. The corresponding registers are continuously collected and periodically refreshed on the PC side.

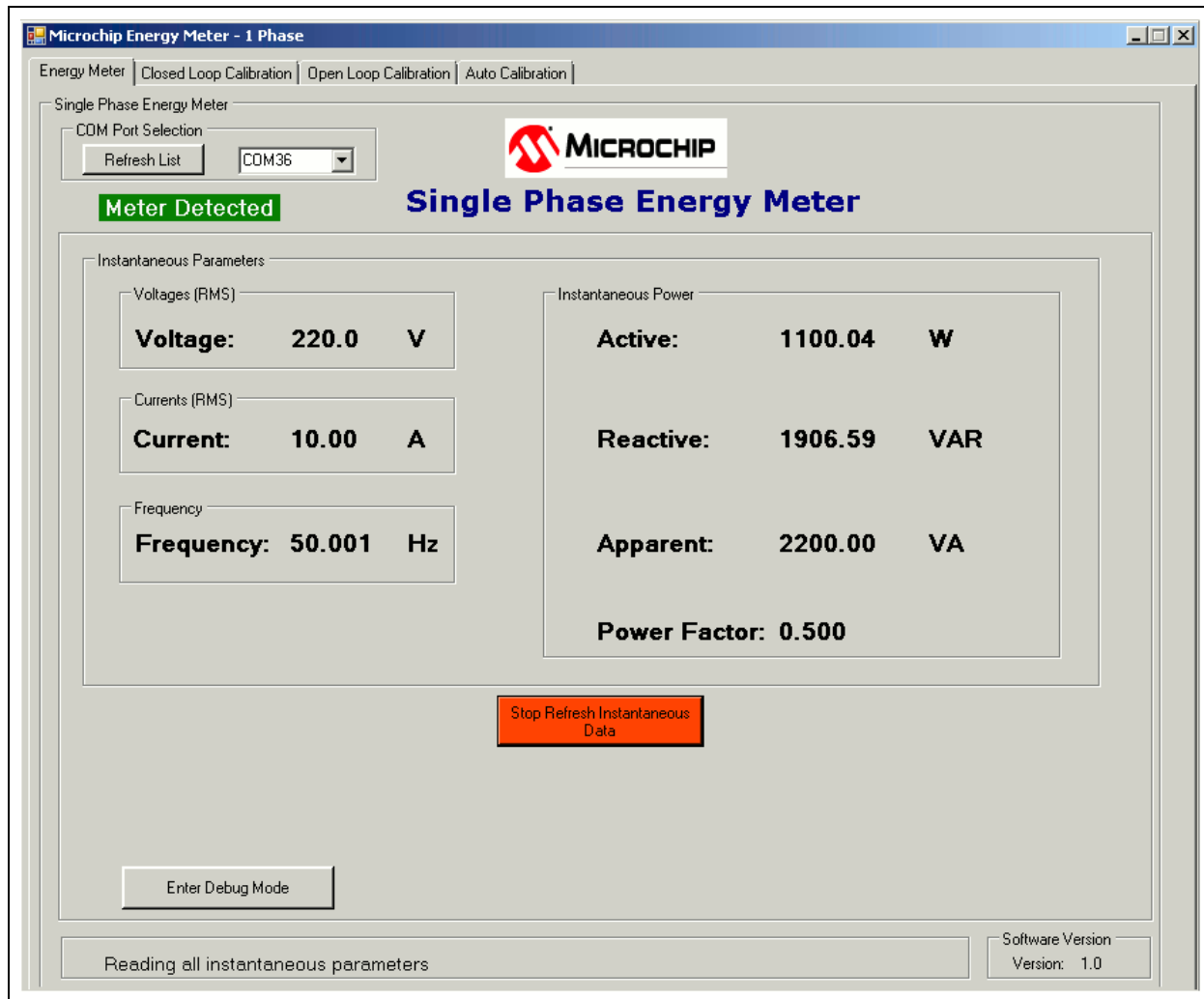

FIGURE 5-2: Energy Meter GUI – Instantaneous Parameters Display.

5.3 DEBUG MODE

The Debug mode feature enables access to all the internal registers of the meter. From the **Energy Meter** tab, click on the **Enter Debug Mode** button on the lower right corner of the tool. The Debug mode screen appears ready for use.

Debug mode displays a complete list of the internal registers of the meter in detail: address, name, attribute, register length and value.

Each register is available for read and write in real time, when the meter is computing.

5.3.1 Refreshing Registers Status

To update all the internal registers, click the **Refresh Meter Registers** button at the bottom of the window, as shown in [Figure 5-3](#). This will update the registers only once per click.

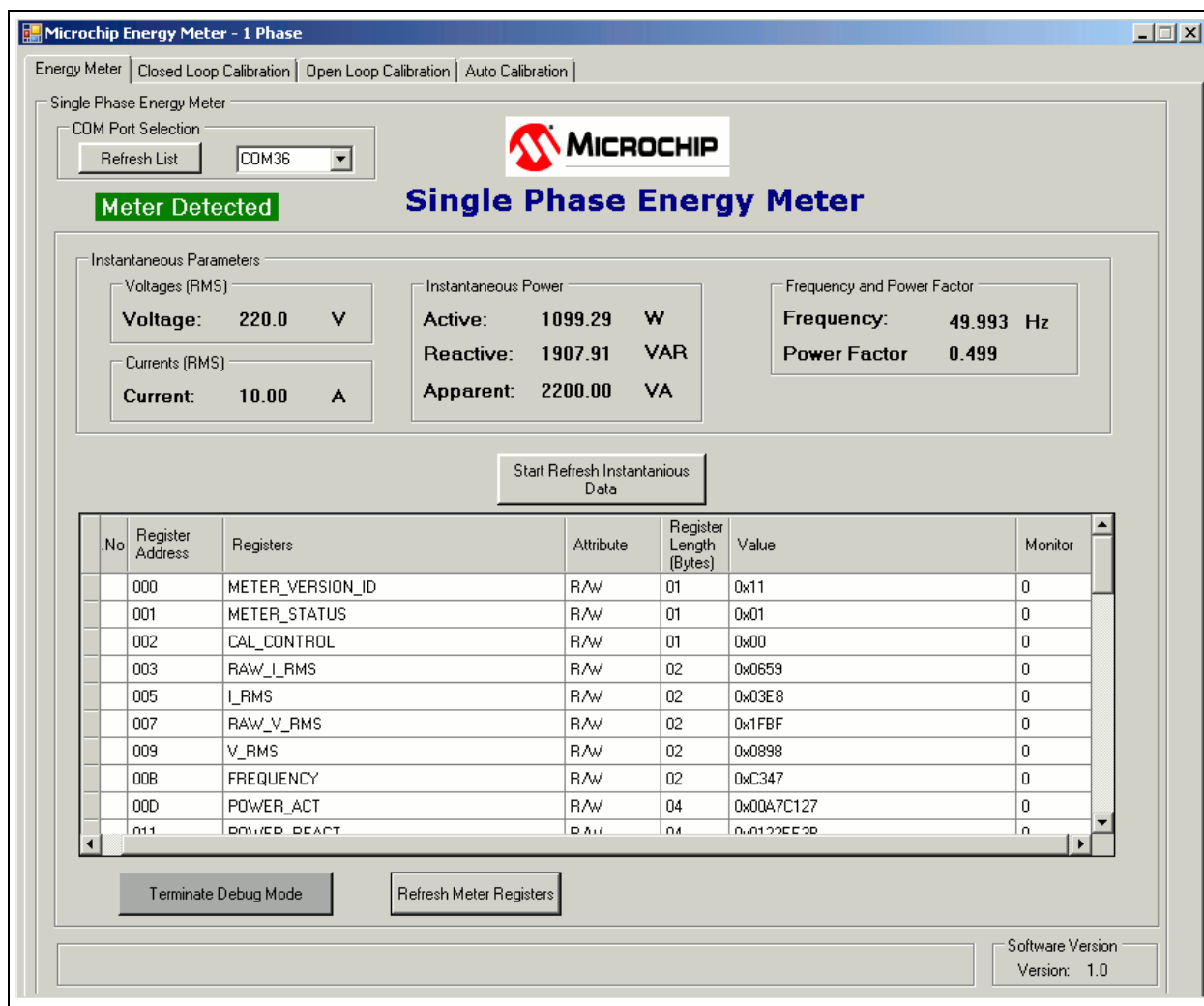

FIGURE 5-3: Energy Meter GUI – Debug Mode.

MCP6L2 and PIC18F66J93 Energy Meter Reference Design

5.3.2 Monitoring Individual Registers

The tool enables the selected registers to be monitored for their real-time updates. Monitoring can be enabled by writing “1” to the column “Monitor” across a particular register, as shown in Figure 5-4. By enabling the monitoring feature, once the **Start Refresh Instantaneous Data** button is pressed, the GUI reads the register periodically, showing the real-time status. Unless monitoring is enabled, the register status is not updated after every instantaneous refresh.

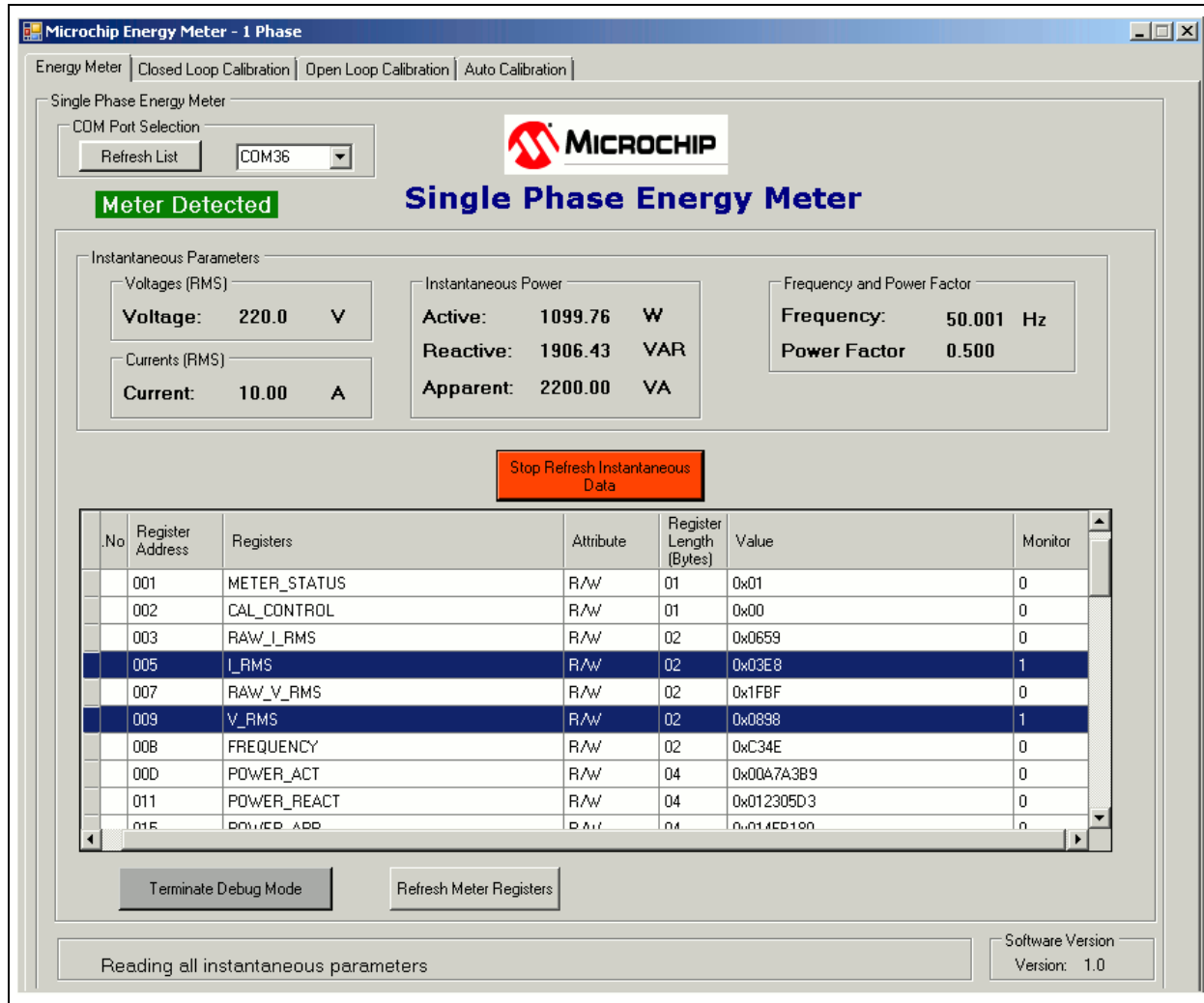

FIGURE 5-4: Energy Meter GUI – Monitoring Individual Registers in Debug Mode.

5.3.3 Writing to Individual Registers

For testing certain limiting conditions and manual tuning the calibration registers, the software offers the option to write to individual registers. To write to a register, enter the value in HEX format (as stored in the registers) in the “Value” column across that particular register and press <Enter> from the keyboard to initiate the write process.

Chapter 6. Energy Meter Calibration

6.1 INTRODUCTION

This chapter describes the methods to calculate calibration parameters. It includes various types of calibration suitable for different stages of meter design.

6.2 CALIBRATION REGISTERS

This registers that need to be calibrated include the following:

- Gain registers:
 - GAIN_V_RMS
 - GAIN_I_RMS_LOW
 - GAIN_I_RMS_HIGH
 - GAIN_POWER_ACT_LOW
 - GAIN_POWER_ACT_HIGH
 - GAIN_NUMR_ENERGY_ACT_LOW
 - GAIN_NUMR_ENERGY_ACT_HIGH
 - GAIN_DENR_ENERGY_ACT_LOW
 - GAIN_DENR_ENERGY_ACT_HIGH
 - GAIN_POWER_REACT_LOW
 - GAIN_POWER_REACT_HIGH
 - GAIN_NUMR_ENERGY_REACT_LOW
 - GAIN_NUMR_ENERGY_REACT_HIGH
 - GAIN_DENR_ENERGY_REACT_LOW
 - GAIN_DENR_ENERGY_REACT_HIGH
- Phase compensation registers:
 - PHASE_COMPENSATION_LOW
 - PHASE_COMPENSATION_HIGH

All the calibration registers, except GAIN_V_RMS, have one set of values for the low-current region and one for the high-current region. Each current region must be calibrated separately. For this purpose, the mechanism that switches automatically between the two current regions can be bypassed by setting the bit called FORCE_CURRENT_REGION, in CAL_CONTROL register. In this mode, the current region is set by the value of the CURRENT_REGION_SELECTED bit, in the same register.

MCP6L2 and PIC18F66J93 Energy Meter Reference Design

6.3 CLOSED LOOP CALIBRATION

6.3.1 Closed Loop Calibration Principle

For this type of calibration, the energy meter must be connected to a calibration device, consisting of a source with configurable RMS Voltage, RMS Current, Power Factor and a Reference Meter. By reading the values indicated by the Reference Meter, and those indicated by the meter to be calibrated, the calibration gain can be computed:

EQUATION 6-1:

$$New_gain = Existing_gain \times \frac{Indication_from_Reference_Meter}{Indication_from_Meter_to_be_calibrated}$$

The indication can be Voltage RMS, Current RMS, Active/Reactive Power, or Active/Reactive Energy Pulses.

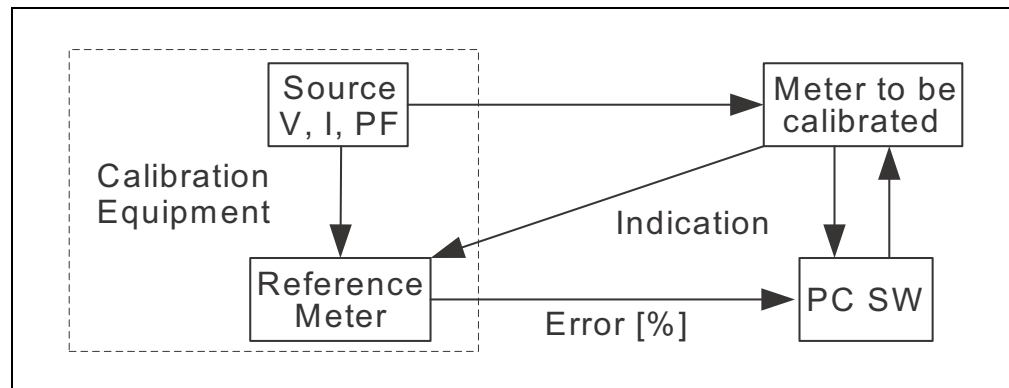

FIGURE 6-1: Closed Loop Calibration Setup.

In the case of energy pulses, the calibration equipment can indicate the error between the period of the pulses from its Reference Meter and the meter to be calibrated. In this case, the previous formula is applied in this form:

EQUATION 6-2:

$$New_gain = \frac{Existing_gain}{\frac{Error[\%]}{100} + 1}$$

The above formulas apply to gain calibration. They are computed for a power factor of 1, except for the Reactive Energy and Power gains, which are computed at a different power factor (usually 0.5).

The information for phase compensation is extracted from the indication of the Active Power at a power factor different than 1 (usually 0.5), after Active Power Gain has been previously computed at the power factor of 1. For more information related to phase compensation calibration, refer to **Section 2.3.2.3 - Phase Compensation** from the "PIC18F87J72 Single-Phase Energy Meter Calibration User's Guide (DS51964)".

6.3.2 Closed Loop Calibration with Microchip Energy Meter Software

Select the **Closed Loop Calibration** tab. The screen from [Figure 6-2](#) appears.

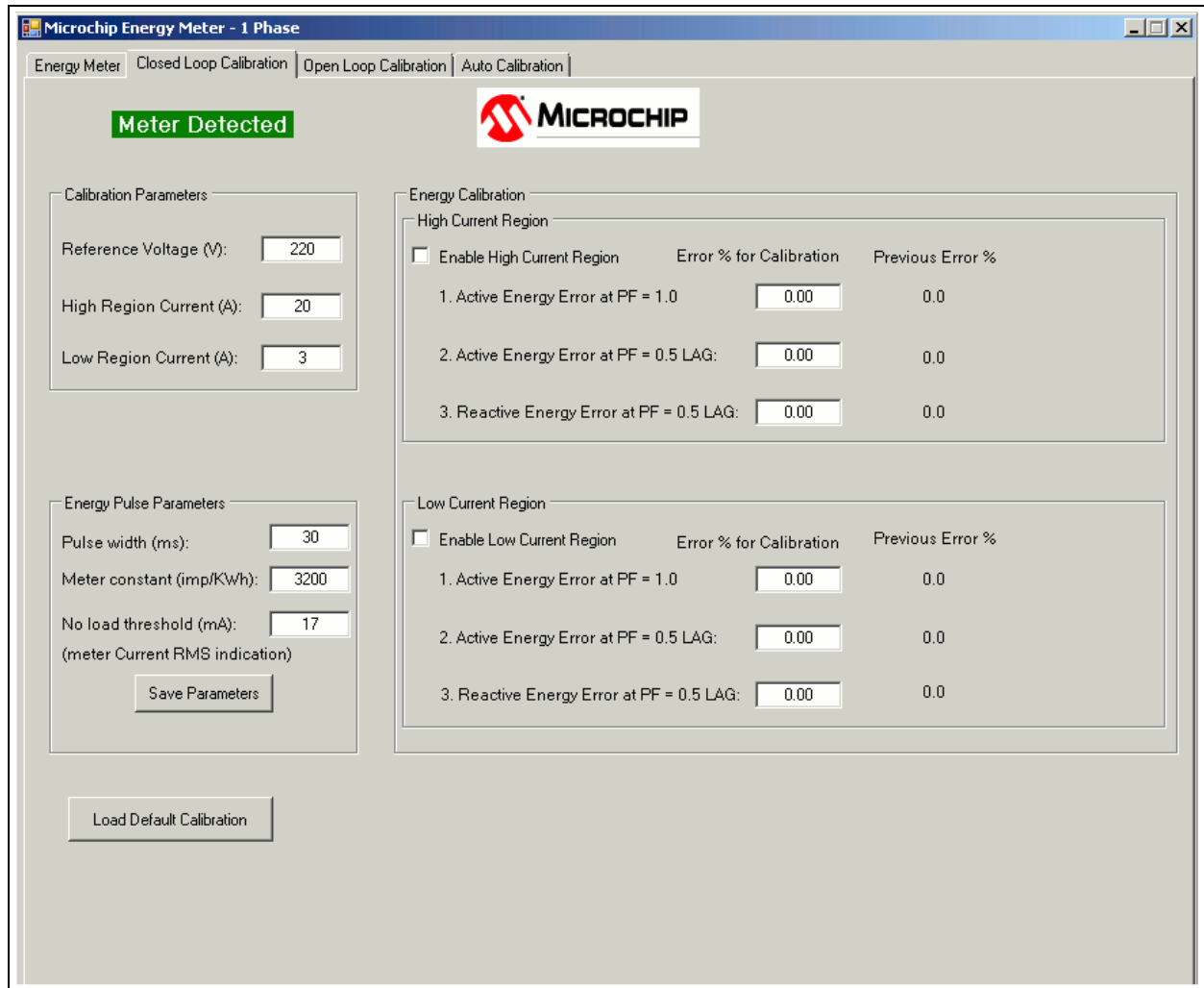

FIGURE 6-2: Closed Loop Calibration Screen.

Before the actual calibration, the default values of the energy pulse parameters can be modified. The software sets the corresponding registers:

- Pulse Width (ms) – PULSE_WIDTH
- Meter Constant (imp/kWh) – METER_CONSTANT
- No Load Threshold (mA) – NO_LOAD_THRESHOLD_I_RMS

After the modification, press the **Save Parameters** button to store the values to EEPROM.

Enter the values indicated by the Reference Meter in the “Calibration Parameters” fields. The recommended calibration values are 220V line voltage, 20A for the high-current region and 3A for the low-current region.

MCP6L2 and PIC18F66J93 Energy Meter Reference Design

To start calibrating the high-current region, configure the source to provide the specified high-region calibration current and select the “Enable High Current Region” check box. The software will configure the corresponding register in the meter and force it to work in the high-current region only. The screen will change, as shown in [Figure 6-3](#).

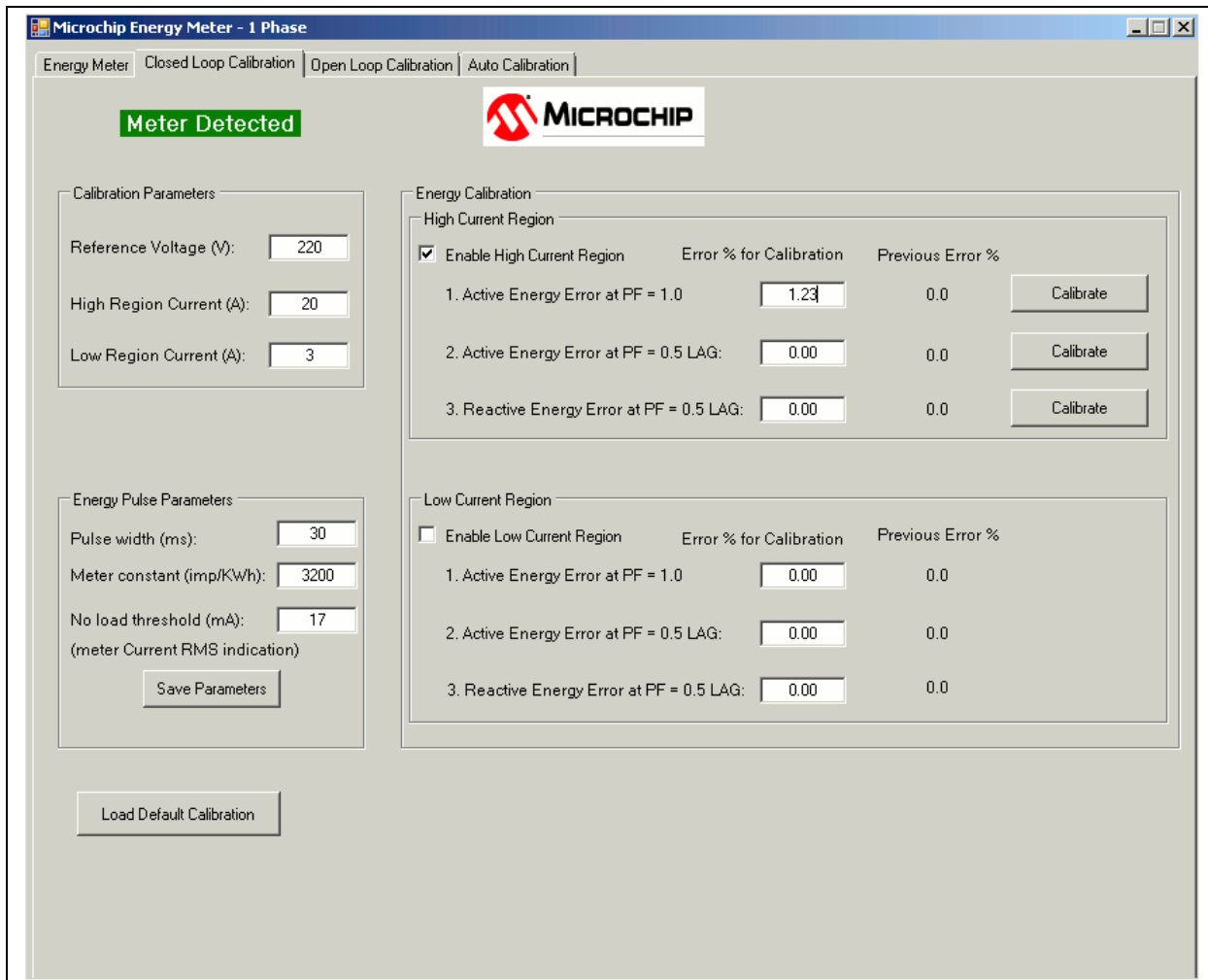

FIGURE 6-3: Closed Loop Calibration – High-Current Region.

The calibration of each current region consists of three stages that must be performed in a specified order. In each stage, proceed with the following steps:

1. Configure the Power Factor from the source.
2. Obtain the indication of the energy pulse error in percentage format from the Reference Meter .
3. Write the error value in the corresponding text box from the screen.
4. Press the corresponding **Calibrate** button.

When **Calibrate** is pressed, the software computes the new values of the following calibration registers, and saves them to EEPROM:

- **High Region, Step 1:** GAIN_V_RMS, GAIN_I_RMS_HIGH, GAIN_POWER_ACT_HIGH, GAIN_NUMR_ENERGY_ACT_HIGH, GAIN_DENR_ENERGY_ACT_HIGH
- **High Region, Step 2:** PHASE_COMPENSATION_HIGH
- **High Region, Step 3:** GAIN_POWER_REACT_HIGH, GAIN_NUMR_ENERGY_REACT_HIGH, GAIN_DENR_ENERGY_REACT_HIGH

Energy Meter Calibration

To calibrate the low-current region, configure the source to provide the specified low-region calibration current and select the “Enable Low Current Region” check box. The software will configure the corresponding register in the meter and force it to work in the low-current region only. The screen will change, as shown in [Figure 6-4](#).

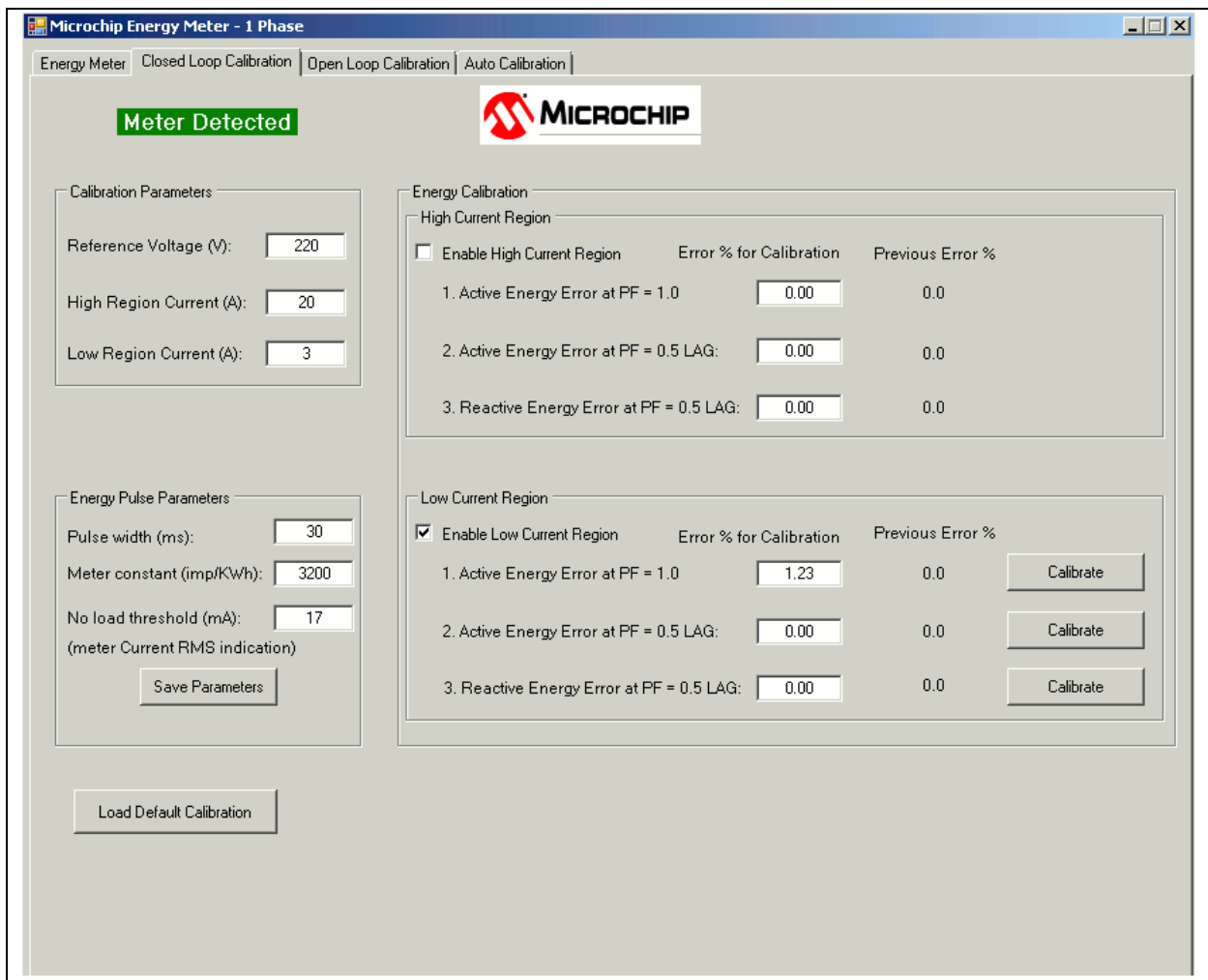

FIGURE 6-4: Closed Loop Calibration – Low-Current Region.

The user must perform the calibration in the same manner as for the high region. When the **Calibrate** button is pressed, the software computes the new values of the following calibration registers, and saves them to EEPROM:

- **Low Region, Step 1:** GAIN_I_RMS_LOW, GAIN_POWER_ACT_LOW, GAIN_NUMR_ENERGY_ACT_LOW, GAIN_DENR_ENERGY_ACT_LOW
- **Low Region, Step 2:** PHASE_COMPENSATION_LOW
- **Low Region, Step 3:** GAIN_POWER_REACT_LOW, GAIN_NUMR_ENERGY_REACT_LOW, GAIN_DENR_ENERGY_REACT_LOW.

After the last calibration step, the software will automatically deselect the “Enable Low Current Region” check box, and the automatic current region selection mechanism from the energy meter will be reactivated.

MCP6L2 and PIC18F66J93 Energy Meter Reference Design

6.4 OPEN LOOP CALIBRATION

6.4.1 Open Loop Calibration Principle

The meter to be calibrated is connected to a source delivering stable, known values of RMS Voltage, RMS Current and Power Factor. This type of calibration does not require a Reference Meter and feedback from the calibration device.

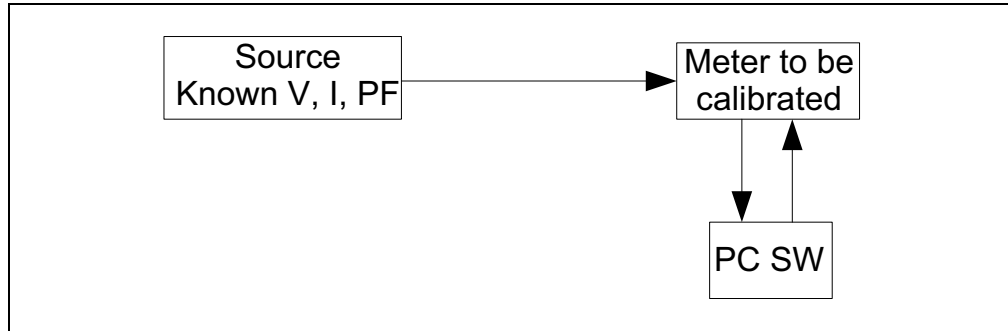

FIGURE 6-5: Open Loop Calibration Setup.

The calibration software running on the PC computes the calibration coefficients based on the values indicated by the meter and the known parameters of the source.

The calibration is done at a single power factor, different than 1 (to include the phase compensation calibration). Usually, this power factor is 0.5.

The calibration parameters are computed differently, depending on the parameter type, as follows:

- **Voltage/Current RMS Gains:** The software running on the PC reads the meter output (RMS indication) and the existing calibration gain. It calculates the new calibration gain with the following formula:

EQUATION 6-3:

$$New_RMS_gain = Existing_RMS_gain \times \frac{Expected_RMS_indication}{Read_RMS_indication}$$

- **Active/Reactive Energy and Power Gains:** The software running on the PC computes these values directly, based on the assumption they are proportional to the Voltage and Current RMS gains:

EQUATION 6-4:

$$Energy(Power)_gain = Voltage_RMS_gain \times Current_RMS_gain \times k$$

The proportionality factors, noted with “k” in the above formula, are hard-coded in the software. They can be computed by knowing all the operations applied in the signal processing chain (bit shifts, number of samples per line cycle, number of cycles per computation cycle), or by the simpler way, computing them from the readings of the RMS and energy/power gains on a calibrated meter.

- **Phase Compensation:** The software on the PC reads the indicated Active Power from the energy meter. By knowing the expected Active Power (since the voltage, current and the applied power factor are already known), it computes the phase compensation. For more information related to phase compensation calibration, refer to **Section 2.3.2.3 - Phase Compensation** in “PIC18F87J72 Single-Phase Energy Meter Calibration User’s Guide (DS51964)”.

6.4.2 Open Loop Calibration with Energy Meter GUI

When the **Open Loop Calibration** tab is selected, the screen in [Figure 6-6](#) will appear.

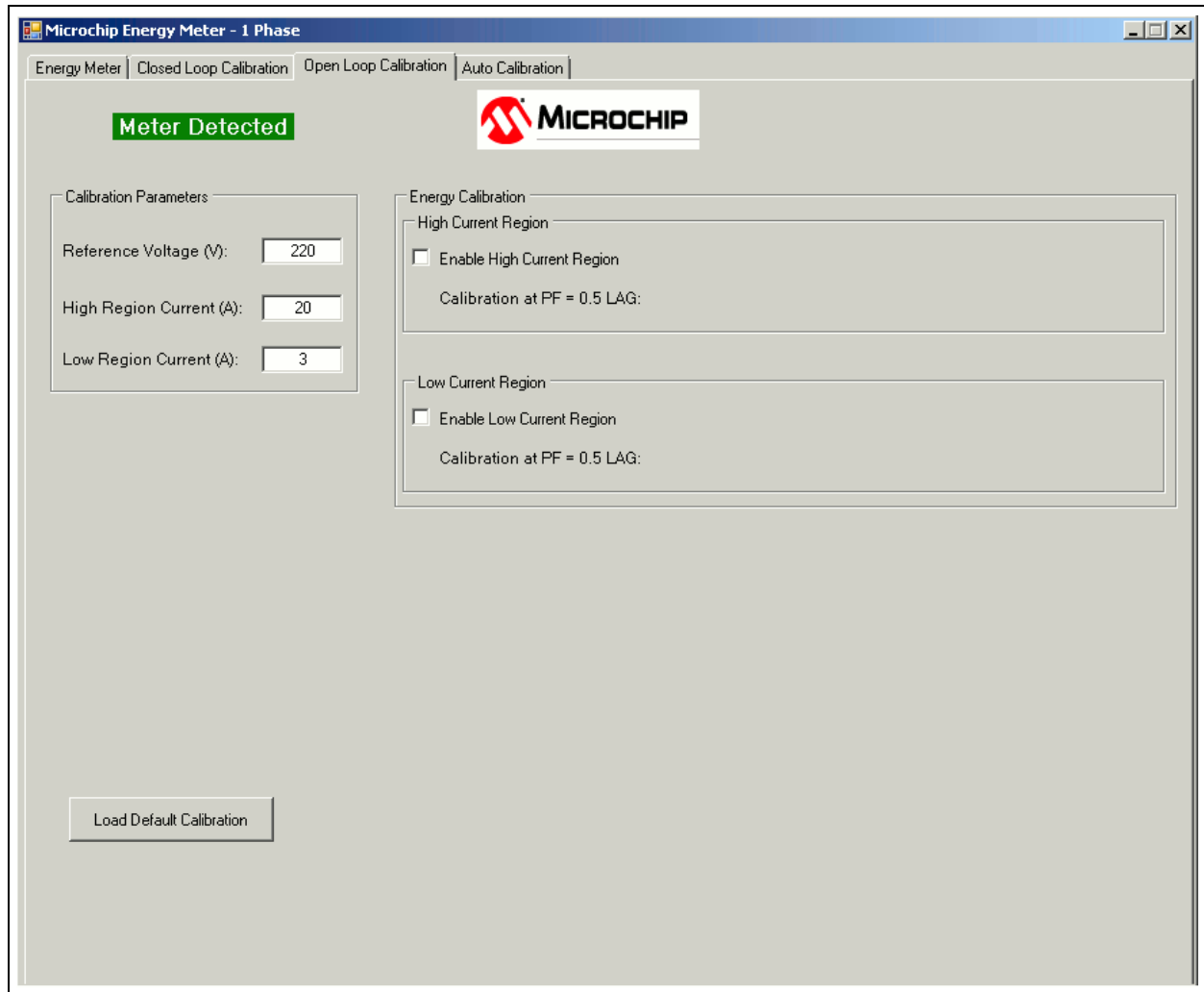

FIGURE 6-6: Open Loop Calibration Screen.

The source must be configured with the parameters specified in the “Calibration Parameters” box. The recommended calibration values are 220V line voltage, 20A for the high-current region, and 3A for the low-current region. The user can modify these values, but it is recommended to have the high-region calibration current higher than 5A, and the low-region calibration current lower than 5A.

MCP6L2 and PIC18F66J93 Energy Meter Reference Design

To start calibrating the high-current region, configure the source to provide the specified high-region calibration current, at power factor of 0.5, and select the “Enable High Current Region” check box. The software will configure the corresponding register in the meter and force it to work in the high-current region only. The following window will appear:

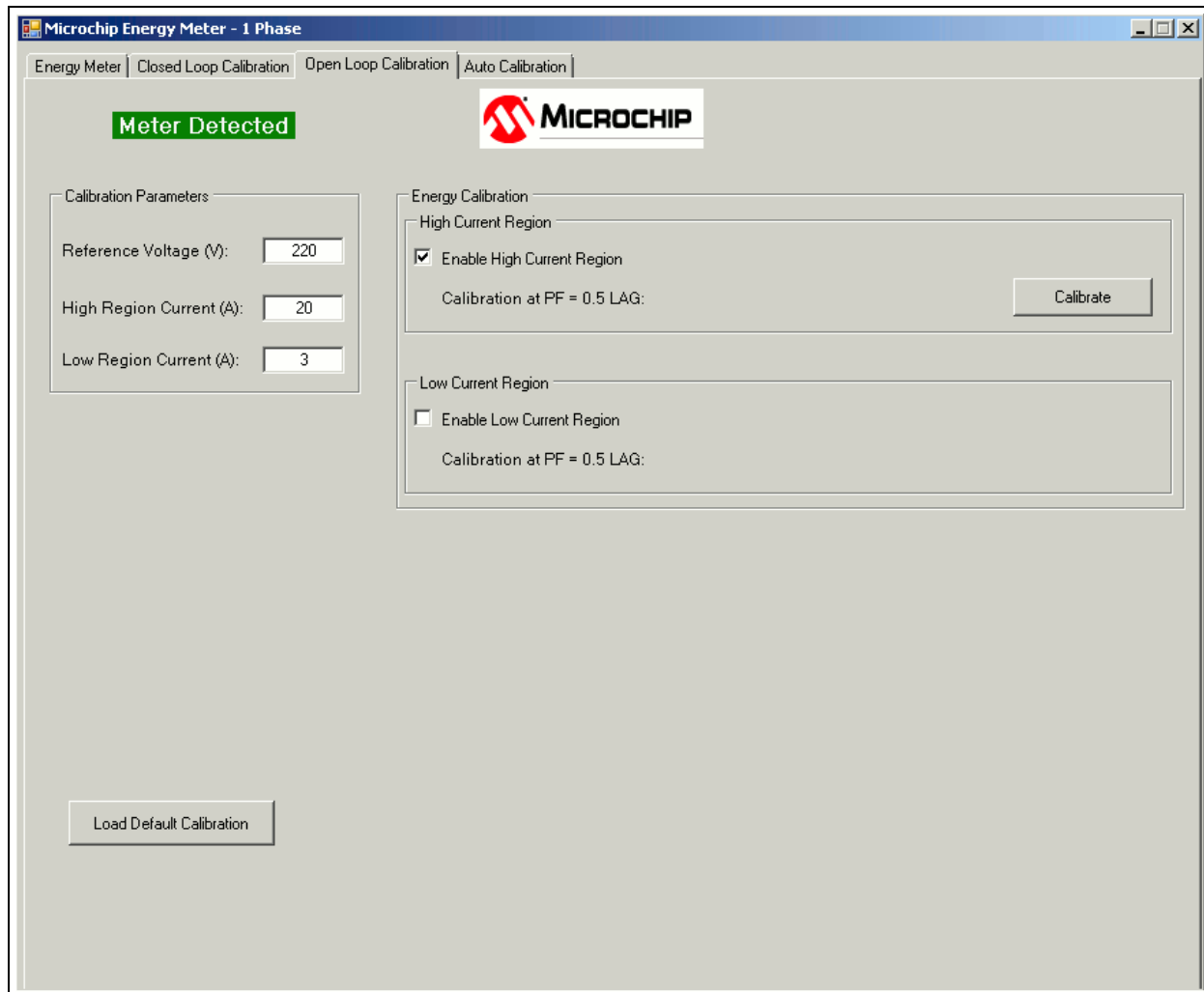

FIGURE 6-7: *Open Loop Calibration – High Current Region*

Press **Calibrate**. The GUI sends a confirmation message when the calibration is complete and the new registers are saved to EEPROM.

At this step, the GUI calibrates all the registers related to the high-current region and the GAIN_V_RMS register. The energy gain registers are calibrated for a meter constant of 3200 imp/kWh.

Energy Meter Calibration

To calibrate the low-current region, configure the source to provide the specified low-region calibration current, at power factor of 0.5, and select the “Enable Low Current Region” check box. The software will configure the corresponding register in the meter and force it to work in the low-current region only. The following window will appear:

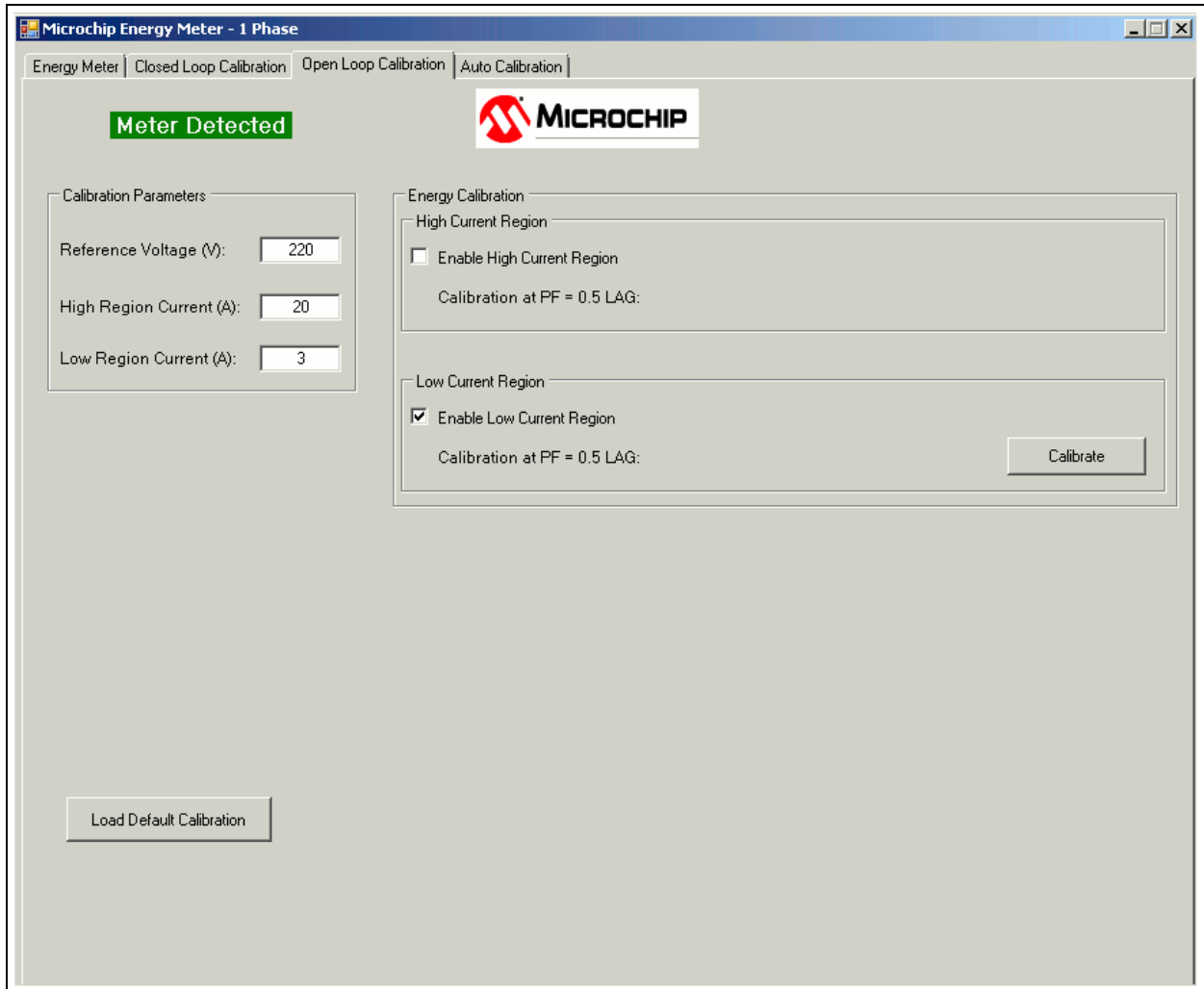

FIGURE 6-8: Open Loop Calibration – Low- Current Region.

Press **Calibrate**. A confirmation message will be sent when the calibration is complete and the new registers are saved to EEPROM.

At this step, the GUI calibrates all the registers related to the low-current region. The energy gain registers are calibrated for a meter constant of 3200 imp/kWh.

6.5 AUTO-CALIBRATION

6.5.1 Auto-Calibration Principle

Auto Calibration is considered to be the open loop calibration routine implemented into the energy meter's firmware. Communication with the PC is not required during this procedure.

The Auto-Calibration routine can be triggered by external events, such as I/O pin state change (from push-button, jumper or other MCU), or UART command (as in this design).

When the trigger event is received, the meter enters into Auto-Calibration mode: it acquires data, computes the calibration parameters and saves them to EEPROM. Then it returns back to Normal mode.

Because the calibration routine occupies a significant size of the program memory, the user has the option to remove it from the code by commenting the statement `#define AUTOCALIBRATION_ENABLE` in the file `Config_EnergyMeter.c`. If the size of the program memory becomes a limitation in the user's custom design, the user may create two firmware versions: one for the calibration, with a reduced set of features, and one with the auto-calibration routine removed and the complete set of features.

The auto-calibration method implemented in this design requires only one current level. Both low- and high-current regions are calibrated at 5A. This value was selected to be in the range of both regions.

The execution time of the auto calibration routine includes the following components:

- the duration of two line cycles (one for the high-current region and one for the low-current region)
- calibration registers calculation time (it is much lower than the duration of a line cycle so it can be neglected)
- the necessary time to store the calibration registers to EEPROM

6.5.2 Auto-Calibration with Energy Meter GUI

When the **Auto Calibration** tab is selected, the following screen appears:

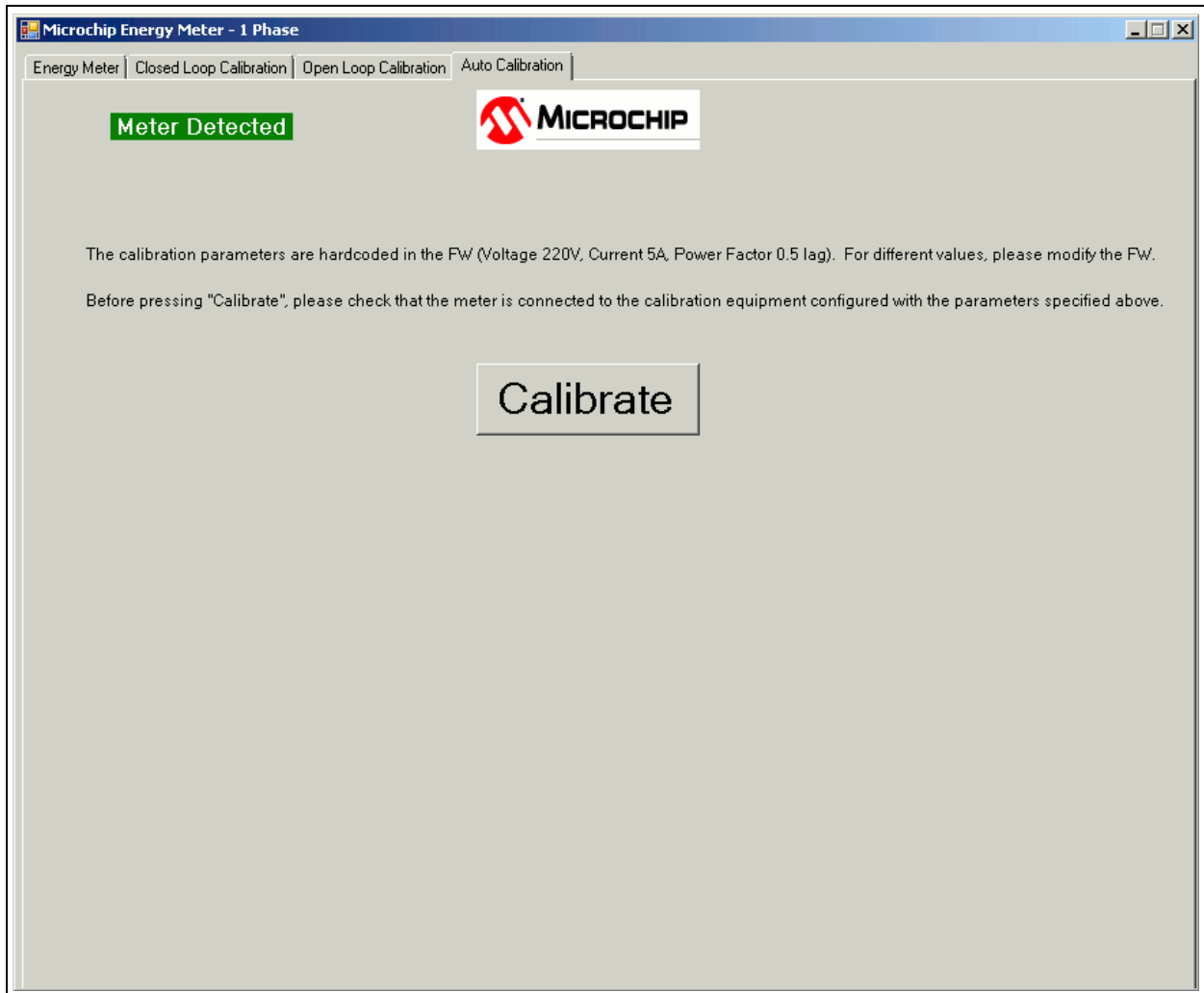

FIGURE 6-9: Auto-Calibration Screen.

The source must be configured with the parameters specified in the text above the **Calibrate** button.

After **Calibrate** is pressed, three possible messages can appear:

- An error message indicating that the auto-calibration routine is not present in the meter code, because the firmware was compiled with the statement `#define AUTOCALIBRATION_ENABLE` commented or missing.
- "Auto Calibration Complete"
- "Communication error. Calibration not done." — this means the GUI did not receive feedback from the energy meter.

In the current firmware version, the energy gain registers are computed for a meter constant of 3200 imp/kWh.

MCP6L2 and PIC18F66J93 Energy Meter Reference Design

NOTES:

Appendix A. Schematic and Layouts

A.1 INTRODUCTION

This appendix contains the following schematics and layouts of the MCP6L2 and PIC18F66J93 Energy Meter:

- Board – Schematic – Analog-to-Digital Converter
- Board – Schematic – Microcontroller
- Board – Schematic – LCD - USB
- Board – Top Silk
- Board – Top Copper
- Board – Top Silk and Copper
- Board – Bottom Silk
- Board – Bottom Copper
- Board – Bottom Silk and Copper

A.2 SCHEMATICS AND PCB LAYOUT

The layer order is shown in [Figure A-1](#).

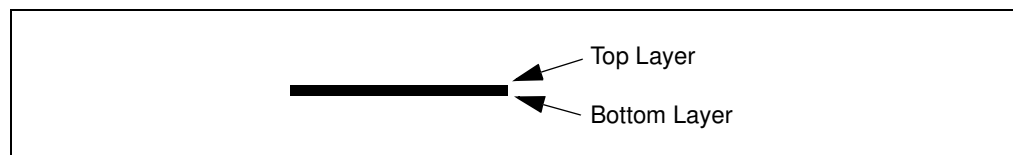
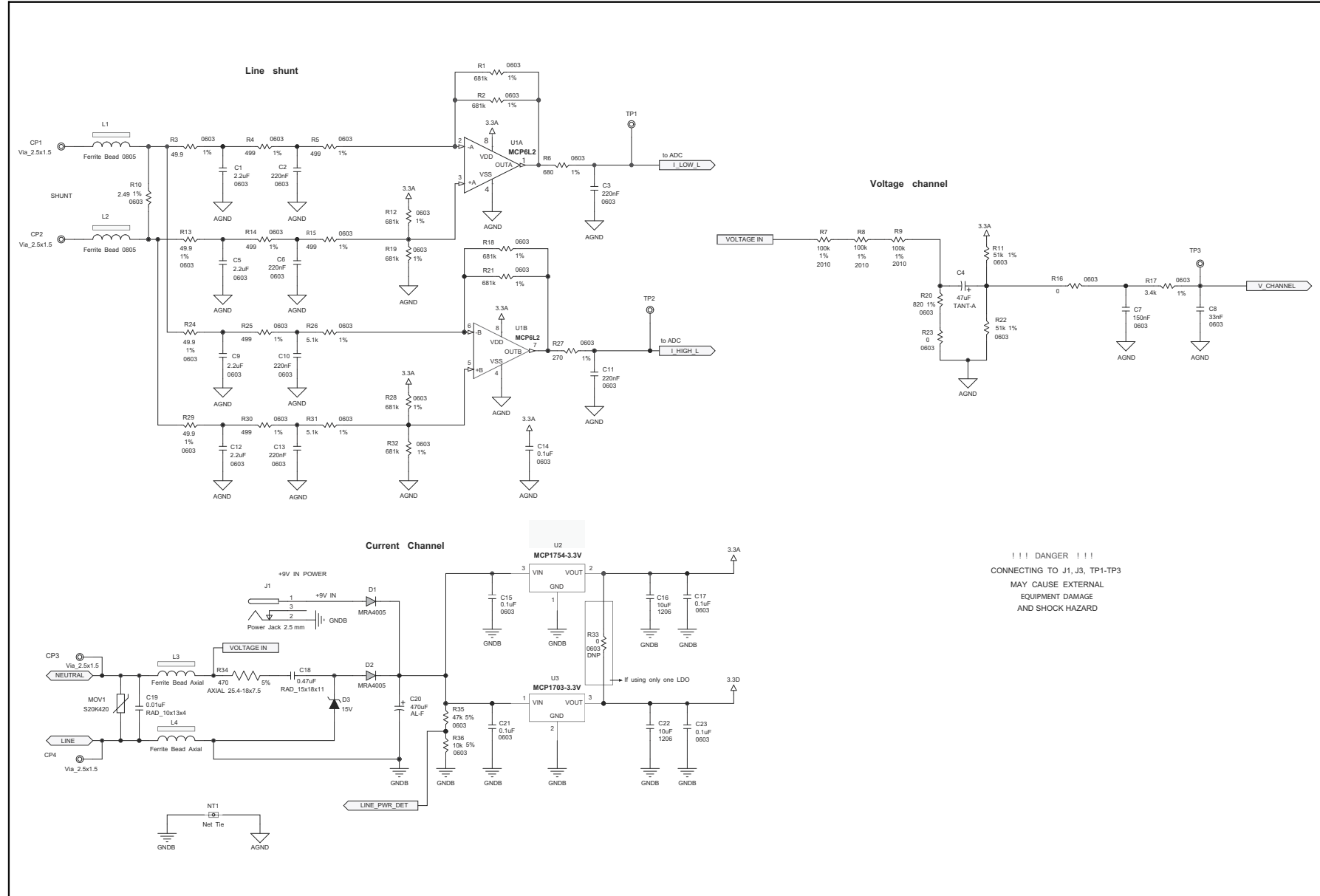
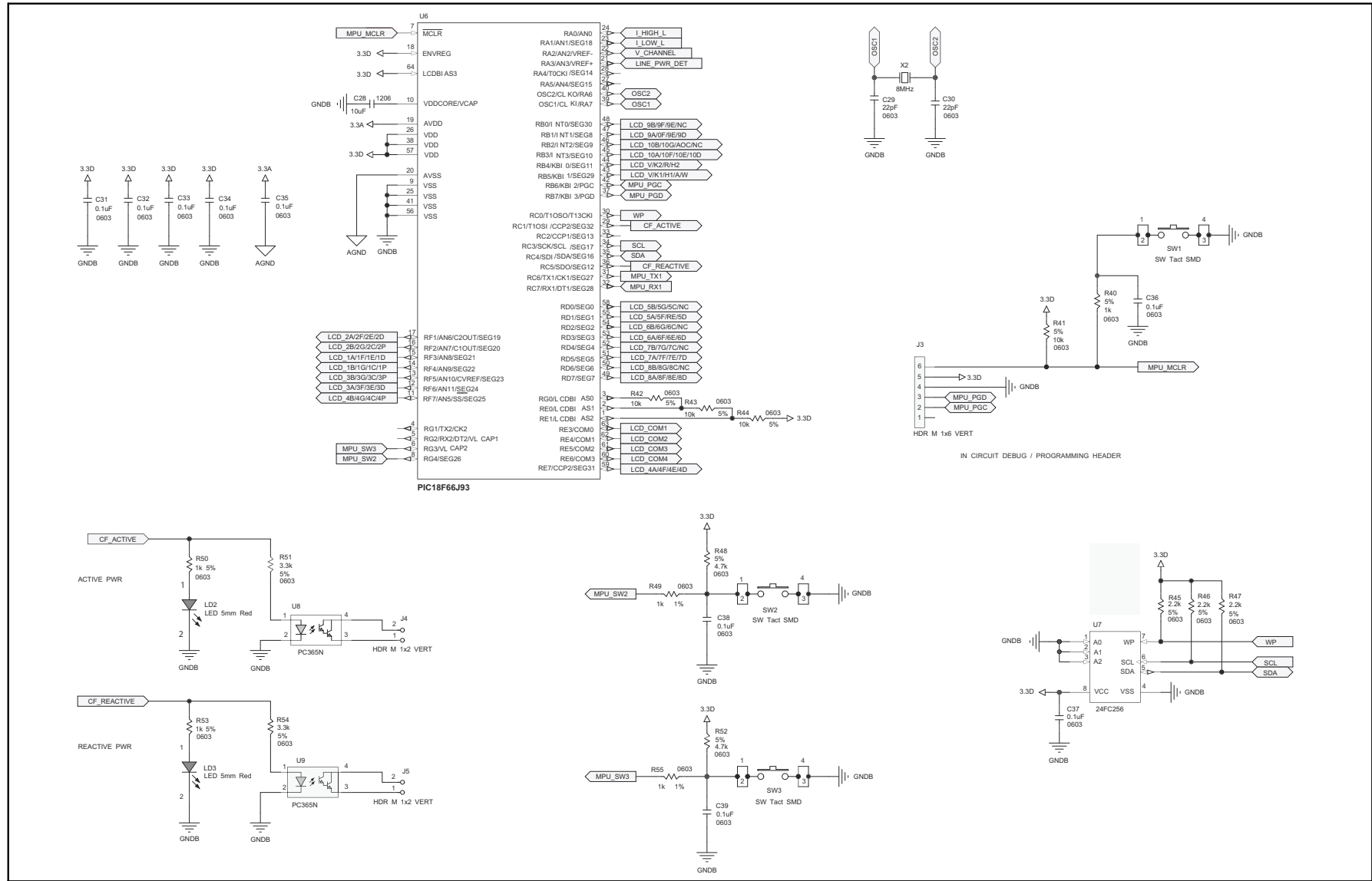

FIGURE A-1: *Layer Order.*

A.3 BOARD – SCHEMATIC – ANALOG-TO-DIGITAL CONVERTER



A.4 BOARD – SCHEMATIC – MICROCONTROLLER



A.5 BOARD – SCHEMATIC – LCD - USB

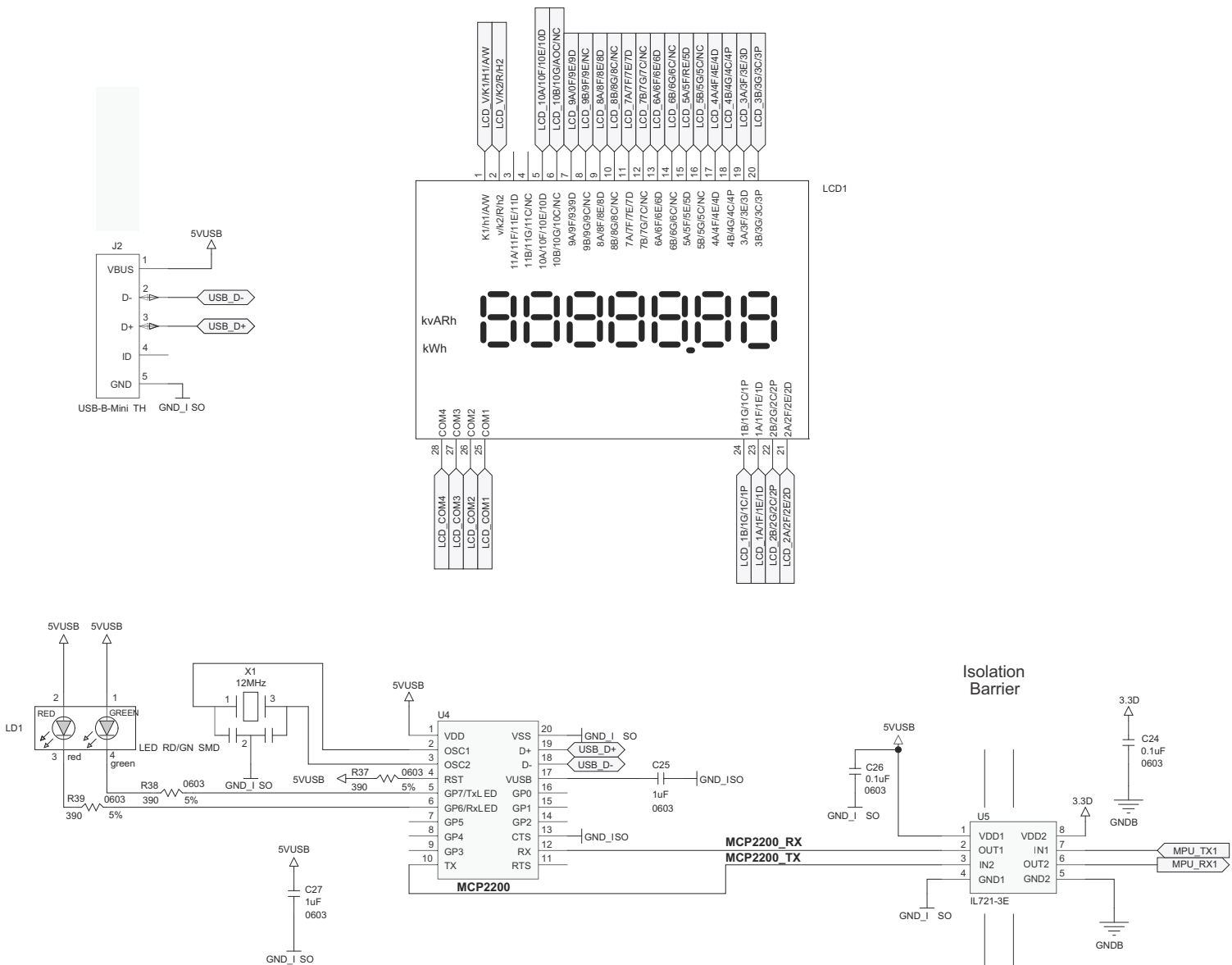

A.6 BOARD – TOP SILK

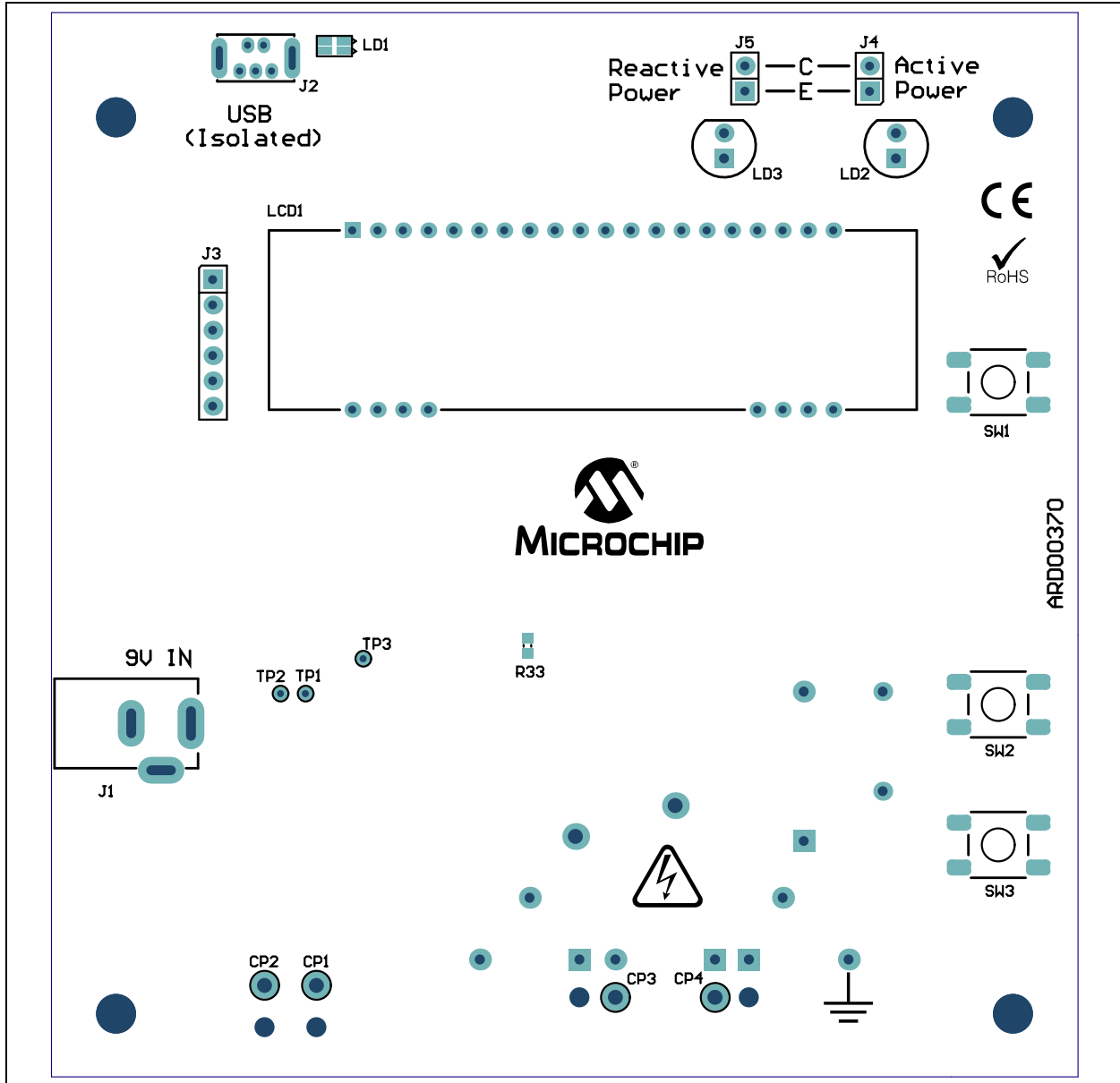

MCP6L2 and PIC18F66J93 Energy Meter Reference Design

A.7 BOARD – TOP COPPER

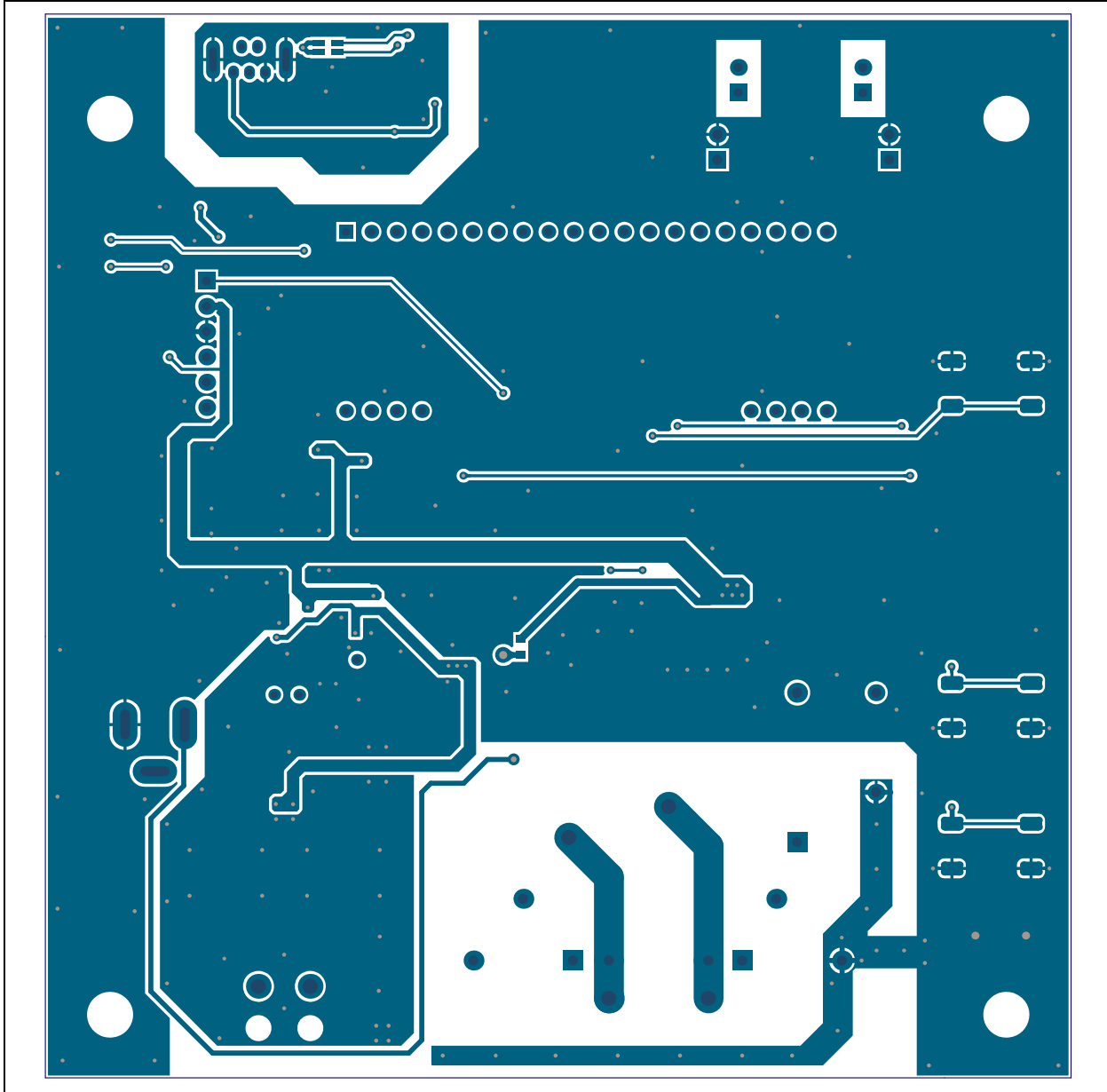

A.8 BOARD – TOP SILK AND COPPER

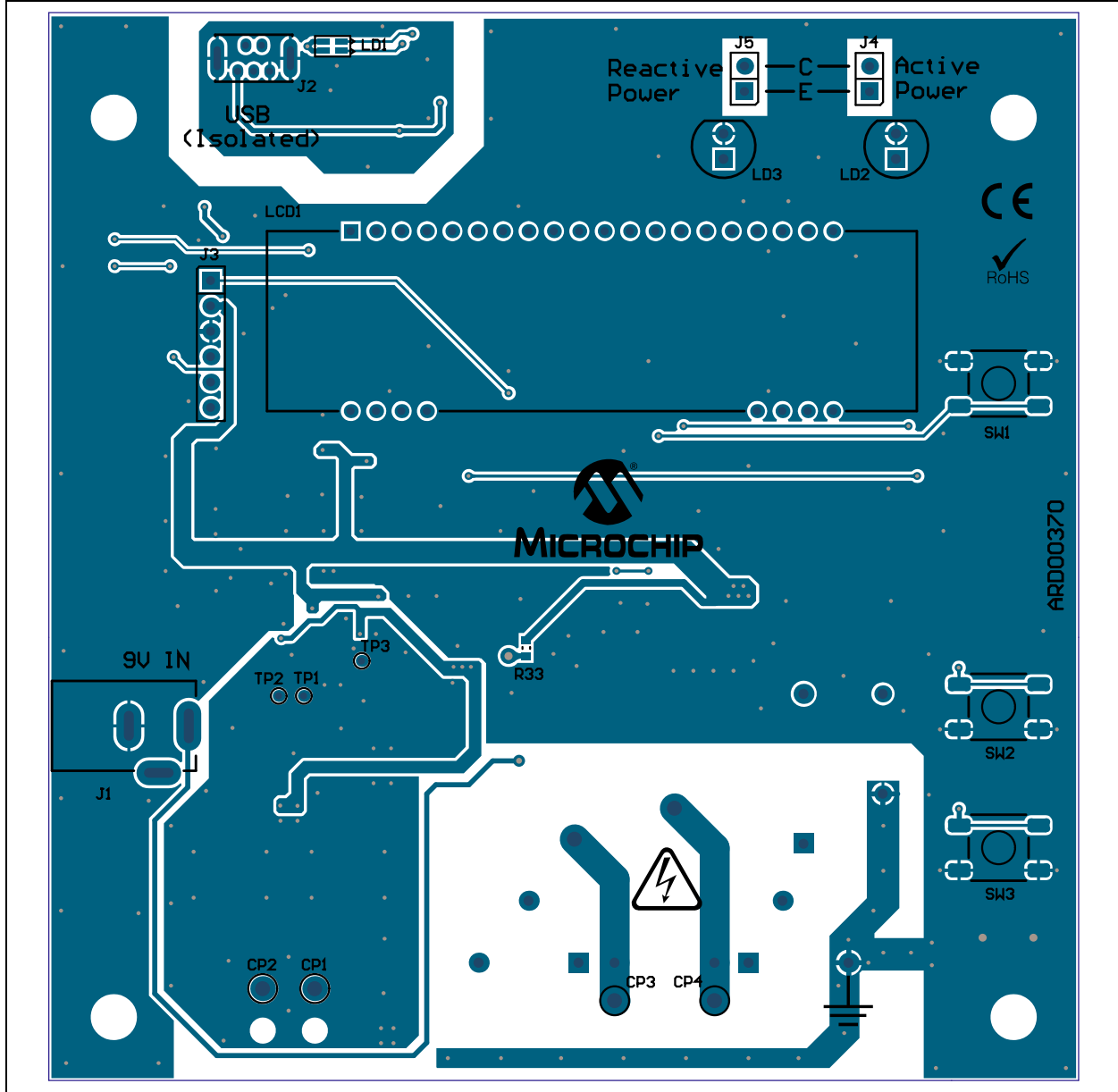

MCP6L2 and PIC18F66J93 Energy Meter Reference Design

A.9 BOARD – BOTTOM SILK

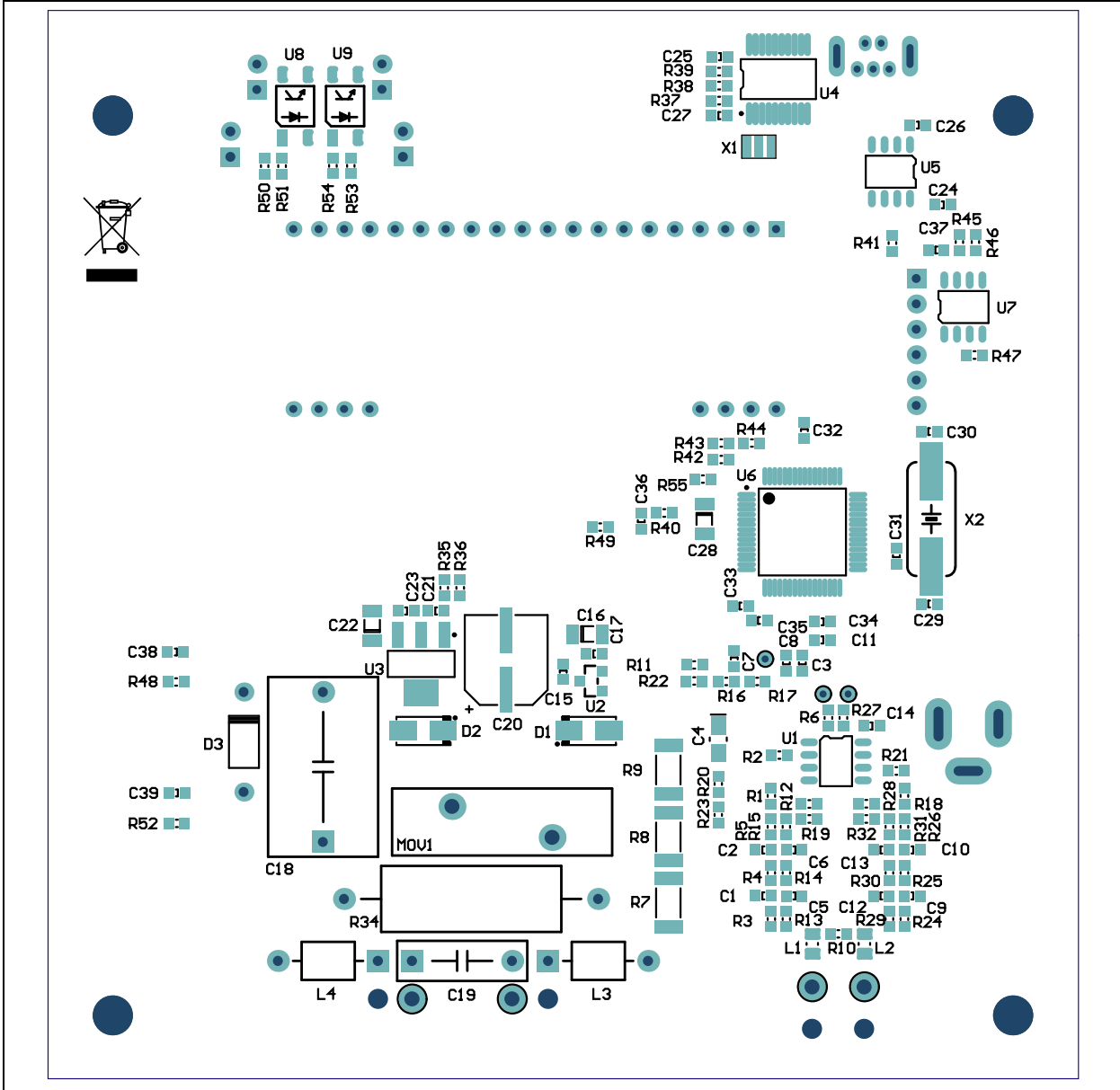

A.10 BOARD – BOTTOM COPPER

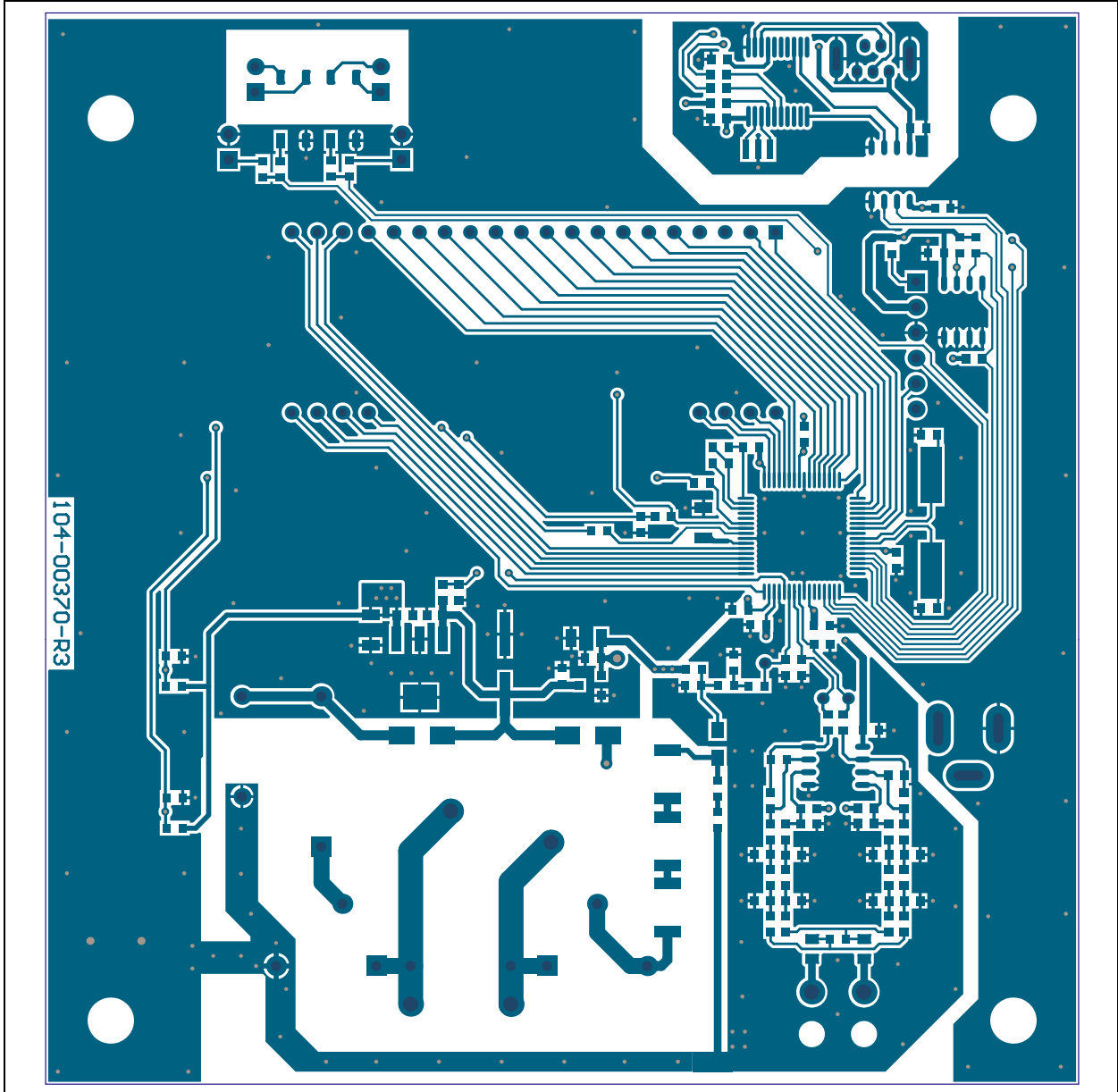

MCP6L2 and PIC18F66J93 Energy Meter Reference Design

A.11 BOARD – BOTTOM SILK AND COPPER

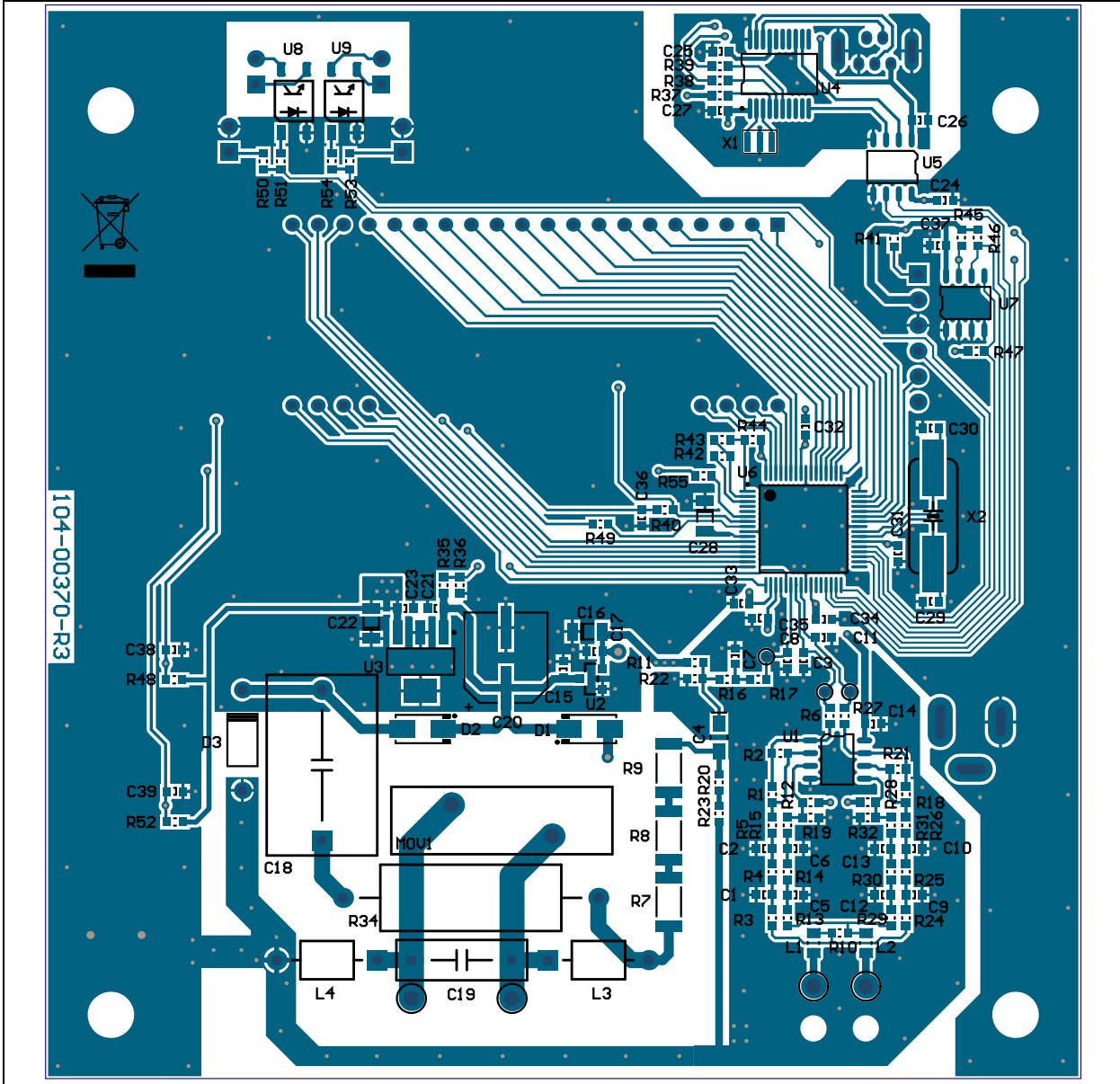



MCP6L2 AND PIC18F66J93 ENERGY METER REFERENCE DESIGN

Appendix B. Bill of Materials (BOM)

TABLE B-1: BILL OF MATERIALS (BOM)

Qty.	Reference	Description	Manufacturer	Part Number
4	C1, C5, C9, C12	Cap. ceramic 2.2 uF 6.3V 10% X7R 0603	TDK [®] Corporation	C1608X7R0J225K
6	C2, C3, C6, C10, C11, C13	Cap. ceramic 0.22 uF 10V 10% X7R 0603	TDK Corporation	C1608X7R1A224K
1	C4	Cap. tant. 47 uF 4V 10% size A	AVX Corporation	TAJA476K004RNJ
1	C7	Cap. ceramic 0.15 uF 16V 10% X7R 0603	TDK Corporation	C1608X7R1C154K
1	C8	Cap. ceramic 33 nF 50V 10% X7R 0603	TDK Corporation	C1608X7R1H333K
16	C14, C15, C17, C21, C23, C24, C26, C31, C32, C33, C34, C35, C36, C37, C38, C39	Cap. ceramic 0.1 uF 16V 10% X7R 0603	TDK Corporation	C1608X7R1C104K
3	C16, C22, C28	Cap. ceramic 10 uF 10V X7R 20% 1206	TDK Corporation	C3216X7R1A106M
1	C18	Cap. film 0.47 uF 305V AC power supply	EPCOS AG	B32932A3474M
1	C19	Cap. film .01 uF 330V AC suppress	EPCOS AG	B32911A3103M
1	C20	Cap. elect. 470 uF 16V 20% VS size F	Panasonic [®] - ECG	EEE-1CA471UP
2	C25, C27	Cap. ceramic 1 uF 10V X7R 20% 0603	TDK Corporation	C1608X7R1A105M
2	C29, C30	Cap. ceramic 22 pF 50V 5% C0G. 0603	TDK Corporation	C1608C0G1H220J
2	D1, D2	Diode STD REC 1A 600V SMA.	ON Semiconductor [®]	MRA4005T3G
1	D3	Diode Zener 15V 1W DO-41	Fairchild Semiconductor [®]	1N4744A
1	J1	Conn. power jack male 2.5 mm clsd.	CUI Inc	PJ-002B
1	J2	Conn. recept. USB TH. vert. 5 pos.	Molex [®]	500075-1517
1	J3	Conn. hdr. male .100 1 x 6 pos. vert.	TE Connectivity, Ltd.	HDR M 1x6 Vertical
2	J4, J5	Conn. hdr. male .100 1 x 2 pos. vert.	TE Connectivity, Ltd.	HDR M 1x2 Vertical
2	L1, L2	Ferrite 800 MA 150 mOhm 0805 SMD.	Laird Technologies [®]	LI0805H151R-10
2	L3, L4	Bead core single 3.8 X 5.3 mm axial	Panasonic - ECG	EXC-ELSA35
1	LD1	LED 2 X 1.2mm rd/gn wtr. clr. SMD.	Kingbright Corporation	APHBM2012SURKCGKC
2	LD2, LD3	LED 5mm RED 640 nm 20 mcd 2 mA	Kingbright Corporation	WP7113LSRD
1	MOV1	Varistor 420 V RMS 20 mm radial	EPCOS AG	S20K420

Note 1: The components listed in this Bill of Materials are representative of the PCB assembly. The released BOM used in manufacturing uses all RoHS-compliant components.

MCP6L2 and PIC18F66J93 Energy Meter Reference Design

TABLE B-1: BILL OF MATERIALS (BOM) (CONTINUED)

Qty.	Reference	Description	Manufacturer	Part Number
1	PCB	Printed Circuit Board – MCP6L2 and PIC18F66J93 Energy Meter Reference Design	—	104-00370
8	R1, R2, R12, R18, R19, R21, R28, R32	Res. 681 kOhm 1/10W 1% 0603 SMD.	Panasonic - ECG	ERJ-3EKF6813V
4	R3, R13, R24, R29	Res. 49.9 Ohm 1/10W 1% 0603 SMD.	Panasonic - ECG	ERJ-3EKF49R9V
6	R4, R5, R14, R15, R25, R30	Res. 499 Ohm 1/10W 1% 0603 SMD.	Panasonic - ECG	ERJ-3EKF4990V
1	R6	Res. 680 Ohm 1/10W 1% 0603 SMD.	Panasonic - ECG	ERJ-3EKF6800V
3	R7, R8, R9	Res. 100 kOhm 3/4W 1% 2010 SMD.	Panasonic - ECG	ERJ-12SF1003U
1	R10	Res. 2.49 Ohm 1/10W 1% 0603 SMD.	Vishay® Intertechnology, Inc.	CRCW06032R49FKEA
2	R11, R22	Res. 51 kOhm 1/10W 1% 0603 SMD.	Panasonic - ECG	ERJ-3EKF5102V
2	R16, R23	Res. 0 Ohm 1/10W 0603 SMD.	Panasonic - ECG	ERJ-3GEY0R00V
1	R17	Res. 3.4 kOhm 1/10W 1% 0603 SMD.	Panasonic - ECG	ERJ-3EKF3401V
1	R20	Res. 820 Ohm 1/10W 1% 0603 SMD.	Panasonic - ECG	ERJ-3EKF8200V
2	R49, R55	Res. 1 kOhm 1/10W 1% 0603 SMD.	Panasonic - ECG	ERJ-3EKF1001V
2	R26, R31	Res. 5.1 kOhm 1/10W 1% 0603 SMD.	Panasonic - ECG	ERJ-3EKF5101V
1	R27	Res. 270 Ohm 1/10W 1% 0603 SMD.	Panasonic - ECG	ERJ-3EKF2700V
1	R34	Res. 470 Ohm 3W 5% axial	Panasonic - ECG	RSMF3JT470R
1	R33	Res. 0 Ohm 1/10W 0603 SMD. - DO NOT POPULATE	Panasonic - ECG	ERJ-3GEY0R00V
1	R35	Res. 47 kOhm 1/10W 5% 0603 SMD.	Panasonic - ECG	ERJ-3GEYJ473V
5	R36, R41, R42, R43, R44	Res. 10 kOhm 1/10W 5% 0603 SMD.	Panasonic - ECG	ERJ-3GEYJ103V
3	R37, R38, R39	Res. 390 Ohm 1/10W 5% 0603 SMD.	Panasonic - ECG	ERJ-3GEYJ391V
3	R40, R50, R53	Res. 1 kOhm 1/10W 5% 0603 SMD.	Panasonic - ECG	ERJ-3GEYJ102V
3	R45, R46, R47	Res. 2.2 kOhm 1/10W 5% 0603 SMD.	Panasonic - ECG	ERJ-3GEYJ222V
2	R48, R52	Res. 4.7 kOhm 1/10W 5% 0603 SMD.	Panasonic - ECG	ERJ-3GEYJ472V
2	R51, R54	Res. 3.3 kOhm 1/10W 5% 0603 SMD.	Panasonic - ECG	ERJ-3GEYJ332V
3	SW1, SW2, SW3	Switch tact. 6 mm 160 GFH = 4.3 mm	Omron Electronics	B3S-1000P
1	U5	Isolator HS dual digital SOIC-8	NVE Corporation	IL721-3E
2	U8, U9	Photocoupler Darl. Out 4-SMD.	Sharp Corporation	PC365NJ0000F
1	X1	Ceramic Resonator 12.0 MHz SMD.	Murata Electronics®	CSTCE12M0G55-R0
1	X2	Crystal 8 MHz 18 pF SMD.	Abracon® Corporation	ABLS-8.000MHZ-B4-T

Note 1: The components listed in this Bill of Materials are representative of the PCB assembly. The released BOM used in manufacturing uses all RoHS-compliant components.

Bill of Materials (BOM)

TABLE B-2: BILL OF MATERIALS – MICROCHIP CONSIGNED PARTS

Qty	Reference	Description	Manufacturer	Part Number
1	LCD1	LCD 7 digits 28 pins	Xiamen Ocular Optics Co., Ltd.	DP076P
1	U1	IC op amp 2.8MHZ 2.7V SOIC-8	Microchip Technology Inc.	MCP6L2T-E/SN
1	U2	IC reg. LDO 150mA 3.3V SOT-23A-3	Microchip Technology Inc.	MCP1754ST-3302E/CB
1	U3	IC reg. LDO 250mA 3.3V SOT-223-3	Microchip Technology Inc.	MCP1703-3302E/DB
1	U4	IC USB to UART SSOP-20	Microchip Technology Inc.	MCP2200-I/SS
1	U6	IC PIC MCU Flash 64K X 4 TQFP-64	Microchip Technology Inc.	PIC18F66J93-I/PT
1	U7	IC EEPROM 256 KBIT 1 MHZ SOIC-8	Microchip Technology Inc.	24FC256-I/SN

Note 1: The components listed in this Bill of Materials are representative of the PCB assembly. The released BOM used in manufacturing uses all RoHS-compliant components.



MICROCHIP

Worldwide Sales and Service

AMERICAS

Corporate Office
2355 West Chandler Blvd.
Chandler, AZ 85224-6199
Tel: 480-792-7200
Fax: 480-792-7277
Technical Support:
<http://www.microchip.com/support>
Web Address:
www.microchip.com

Atlanta
Duluth, GA
Tel: 678-957-9614
Fax: 678-957-1455

Boston
Westborough, MA
Tel: 774-760-0087
Fax: 774-760-0088

Chicago
Itasca, IL
Tel: 630-285-0071
Fax: 630-285-0075

Cleveland
Independence, OH
Tel: 216-447-0464
Fax: 216-447-0643

Dallas
Addison, TX
Tel: 972-818-7423
Fax: 972-818-2924

Detroit
Farmington Hills, MI
Tel: 248-538-2250
Fax: 248-538-2260

Indianapolis
Noblesville, IN
Tel: 317-773-8323
Fax: 317-773-5453

Los Angeles
Mission Viejo, CA
Tel: 949-462-9523
Fax: 949-462-9608

Santa Clara
Santa Clara, CA
Tel: 408-961-6444
Fax: 408-961-6445

Toronto
Mississauga, Ontario,
Canada
Tel: 905-673-0699
Fax: 905-673-6509

ASIA/PACIFIC

Asia Pacific Office
Suites 3707-14, 37th Floor
Tower 6, The Gateway
Harbour City, Kowloon
Hong Kong
Tel: 852-2401-1200
Fax: 852-2401-3431

Australia - Sydney
Tel: 61-2-9868-6733
Fax: 61-2-9868-6755

China - Beijing
Tel: 86-10-8569-7000
Fax: 86-10-8528-2104

China - Chengdu
Tel: 86-28-8665-5511
Fax: 86-28-8665-7889

China - Chongqing
Tel: 86-23-8980-9588
Fax: 86-23-8980-9500

China - Hangzhou
Tel: 86-571-2819-3187
Fax: 86-571-2819-3189

China - Hong Kong SAR
Tel: 852-2943-5100
Fax: 852-2401-3431

China - Nanjing
Tel: 86-25-8473-2460
Fax: 86-25-8473-2470

China - Qingdao
Tel: 86-532-8502-7355
Fax: 86-532-8502-7205

China - Shanghai
Tel: 86-21-5407-5533
Fax: 86-21-5407-5066

China - Shenyang
Tel: 86-24-2334-2829
Fax: 86-24-2334-2393

China - Shenzhen
Tel: 86-755-8864-2200
Fax: 86-755-8203-1760

China - Wuhan
Tel: 86-27-5980-5300
Fax: 86-27-5980-5118

China - Xian
Tel: 86-29-8833-7252
Fax: 86-29-8833-7256

China - Xiamen
Tel: 86-592-2388138
Fax: 86-592-2388130

China - Zhuhai
Tel: 86-756-3210040
Fax: 86-756-3210049

ASIA/PACIFIC

India - Bangalore
Tel: 91-80-3090-4444
Fax: 91-80-3090-4123

India - New Delhi
Tel: 91-11-4160-8631
Fax: 91-11-4160-8632

India - Pune
Tel: 91-20-2566-1512
Fax: 91-20-2566-1513

Japan - Osaka
Tel: 81-6-6152-7160
Fax: 81-6-6152-9310

Japan - Tokyo
Tel: 81-3-6880-3770
Fax: 81-3-6880-3771

Korea - Daegu
Tel: 82-53-744-4301
Fax: 82-53-744-4302

Korea - Seoul
Tel: 82-2-554-7200
Fax: 82-2-558-5932 or
82-2-558-5934

Malaysia - Kuala Lumpur
Tel: 60-3-6201-9857
Fax: 60-3-6201-9859

Malaysia - Penang
Tel: 60-4-227-8870
Fax: 60-4-227-4068

Philippines - Manila
Tel: 63-2-634-9065
Fax: 63-2-634-9069

Singapore
Tel: 65-6334-8870
Fax: 65-6334-8850

Taiwan - Hsin Chu
Tel: 886-3-5778-366
Fax: 886-3-5770-955

Taiwan - Kaohsiung
Tel: 886-7-213-7828
Fax: 886-7-330-9305

Taiwan - Taipei
Tel: 886-2-2508-8600
Fax: 886-2-2508-0102

Thailand - Bangkok
Tel: 66-2-694-1351
Fax: 66-2-694-1350

EUROPE

Austria - Wels
Tel: 43-7242-2244-39
Fax: 43-7242-2244-393

Denmark - Copenhagen
Tel: 45-4450-2828
Fax: 45-4485-2829

France - Paris
Tel: 33-1-69-53-63-20
Fax: 33-1-69-30-90-79

Germany - Munich
Tel: 49-89-627-144-0
Fax: 49-89-627-144-44

Italy - Milan
Tel: 39-0331-742611
Fax: 39-0331-466781

Netherlands - Drunen
Tel: 31-416-690399
Fax: 31-416-690340

Spain - Madrid
Tel: 34-91-708-08-90
Fax: 34-91-708-08-91

UK - Wokingham
Tel: 44-118-921-5869
Fax: 44-118-921-5820

11/29/12