

LOC		DIST		REVISIONS			
P	LTR	DESCRIPTION	DATE	DWN	APVD		
P		REV PER ECO-15-016062	10NOV15	KG	CD		

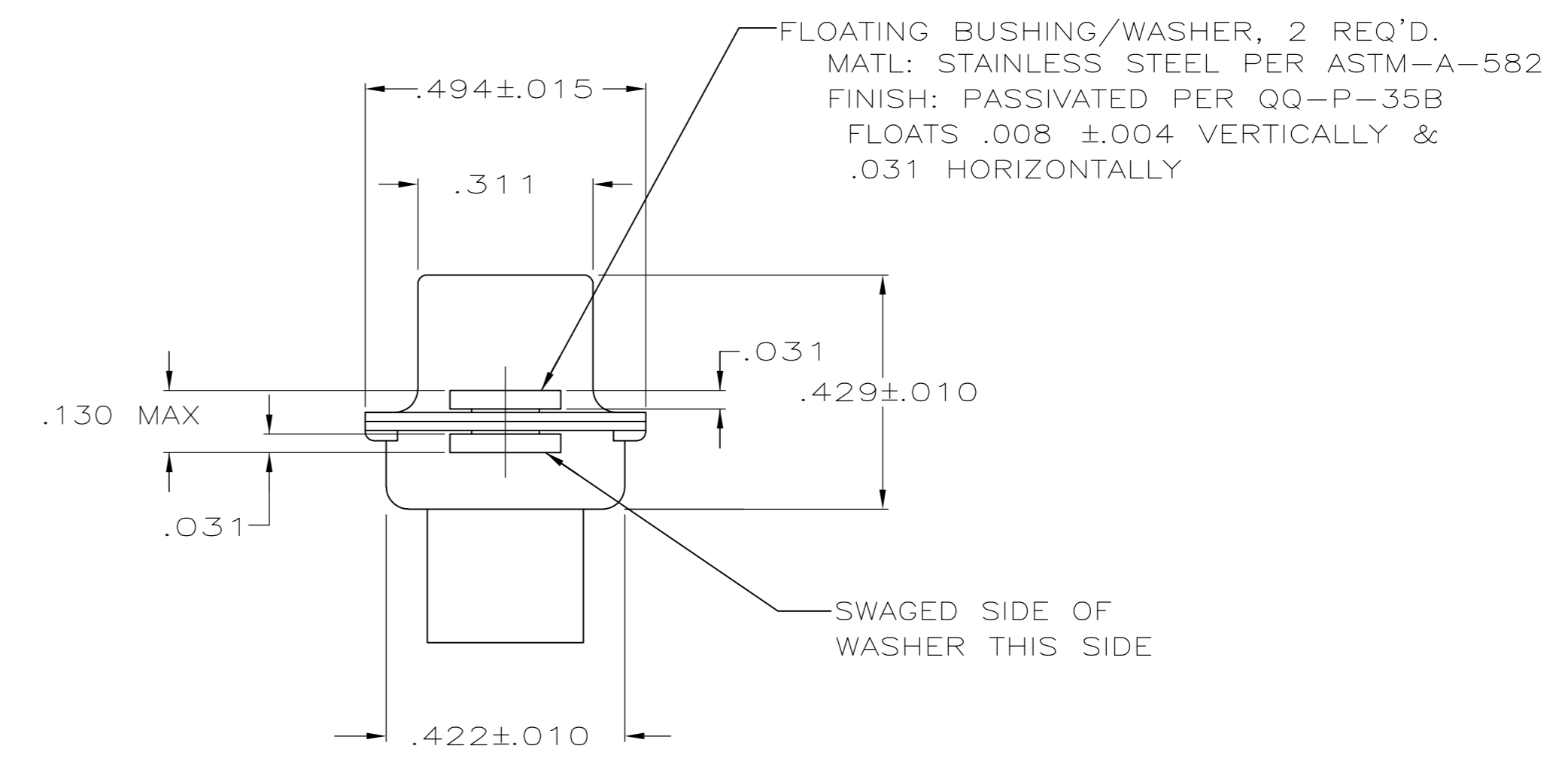
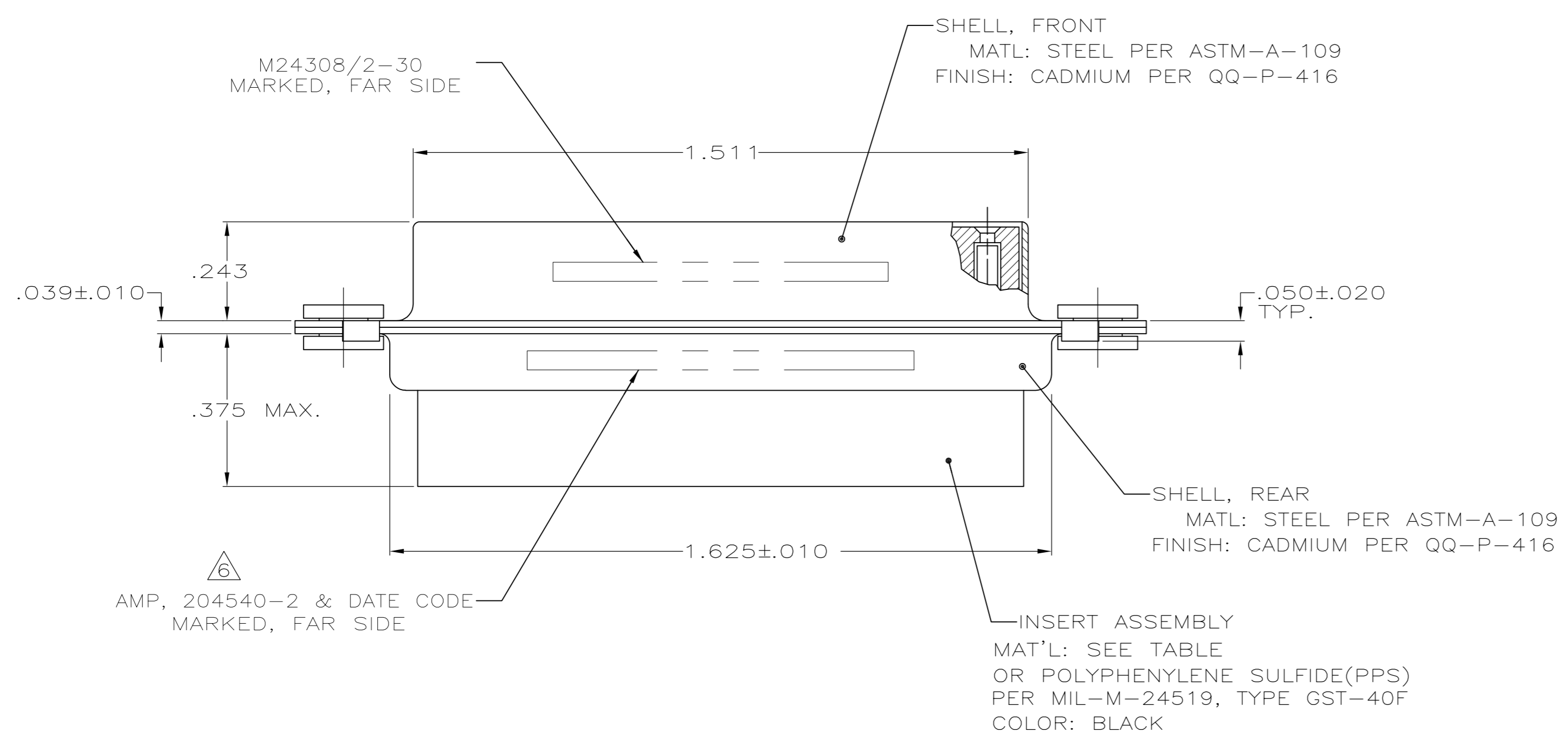
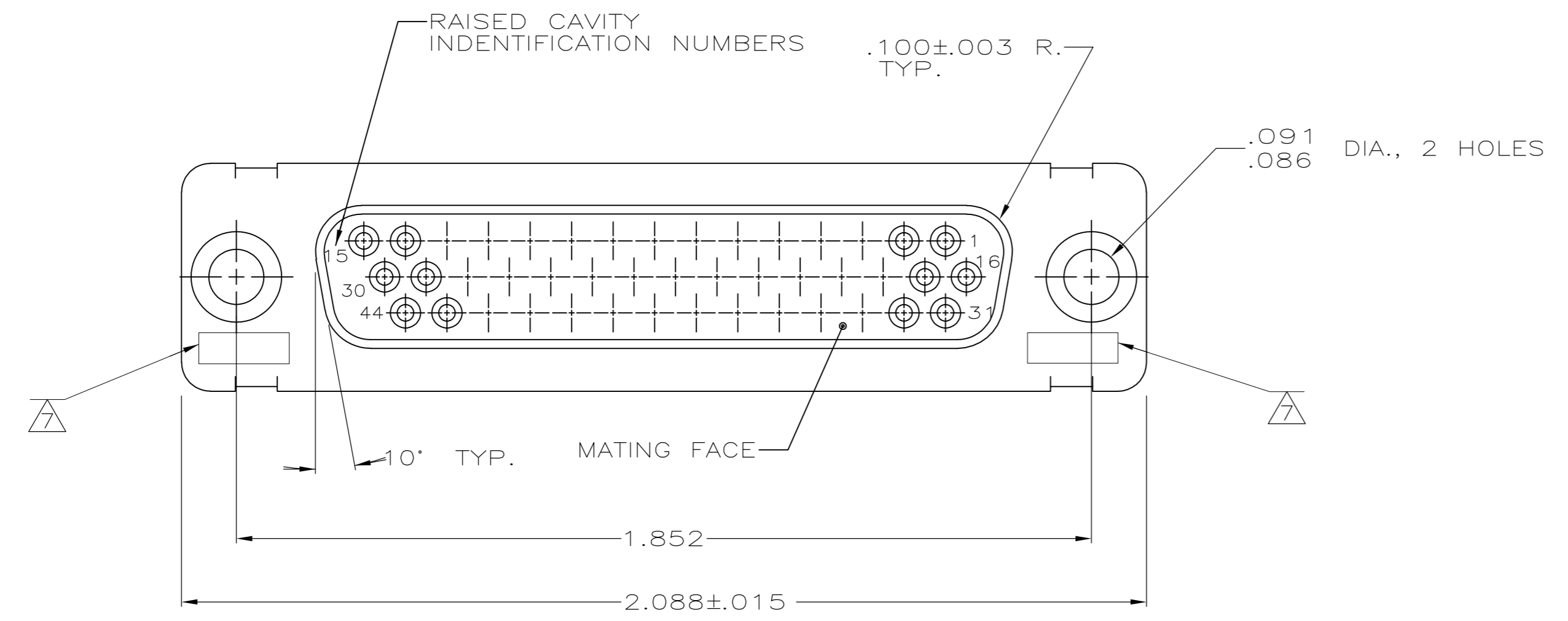

- THIS RCPT. IS DESIGNED TO CONFORM TO THE LATEST ISSUE OF MIL-C-24308
 - MAX WIRE INSUL TO BE USED WITH THIS RCPT IS .054 DIA
 - METAL RETENTION CLIPS ARE INCLUDED IN INSERTS
 - PACKAGE MARKED M 24308/2-299F
 - THIS RCPT. WILL ACCEPT SIZE 22 SOCKET CONTACT M 24308/12 OR AMP # 204351
- △ AMP PART NO. MARKED ON CONNECTOR REPRESENTS KIT NUMBER WITH CONTACTS
 ▽ UL/CSA DESIGNATION MARKED IN THIS AREA,OPTIONAL

OBSELETE	PHENOLIC, COLOR: BLACK	204528-2
	POLYPHENYLENE SULFIDE (PPS) GST-40F PER MIL-M-24519 OR GLASS FILLED POLYESTER TPES013G30 PER ASTM D5927 COLOR, BLACK	204528-1
	INSERT MATERIAL	PART NO.

THIS DRAWING IS A CONTROLLED DOCUMENT.

DIMENSIONS: INCHES	TOLERANCES UNLESS OTHERWISE SPECIFIED:	DWN: C.C.THOMAS 12-3-87	CHK: F.C.BALLEW 1-25-88	APVD: DJM 1-25-88	NAME: AMPLITE RCPT FOR SOCKET CONTACTS HI-DENSITY D CONN, SIZE 3, SERIES 90 WITH FLOAT BUSHINGS
0 PLC ± -	1 PLC ± -	2 PLC ± -	3 PLC ± .005	4 PLC ± -	SIZE: A1
ANGLES ± -	FINISH: SEE CALLOUTS	WEIGHT: -	CAGE CODE: 00779	DRAWING NO: 204528	RESTRICTED TO: -
MATERIAL: SEE CALLOUTS	SEE CALLOUTS	CUSTOMER DRAWING	SCALE: 4:1	SHEET: 1 OF 1	REV: P

STE TE Connectivity