

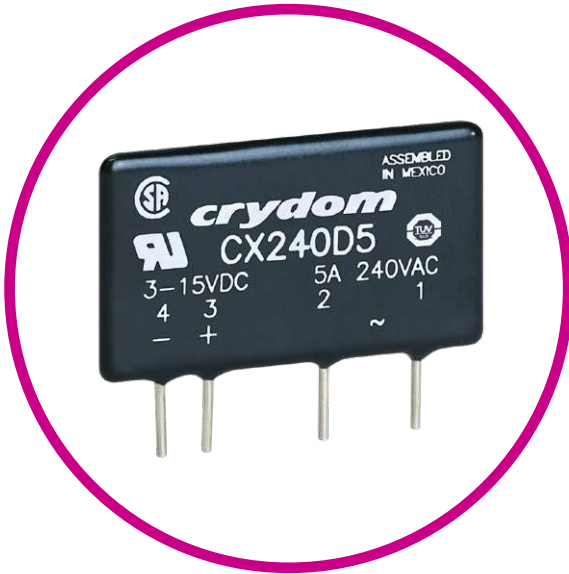

CX SERIES

PCB MOUNT SOLID STATE RELAYS



Features

- SIP SSR
- Ratings of 5 A @ 660 VAC
- SCR output for heavy industrial loads
- AC or DC control
- Zero-crossing (resistive loads) or random-fire (inductive loads) output
- CE Compliant to EN60950-1

PRODUCT SELECTION

Control Voltage	5 A	5 A	5 A
3-15 VDC	CX240D5		
4-15 VDC		CX380D5	CX480D5
15-32 VDC	CXE240D5	CXE380D5	CXE480D5
18-36 VAC	CXE240A5		
90-140 VAC	CX240A5		

● SPECIFICATIONS

Output ⁽¹⁾

Description	CX240x5	CX380x5	CX480x5
Operating Voltage (47-63Hz) [Vrms]	12-280	48-530	48-660
Transient Overvoltage [Vpk]	600	1200	1200
Maximum Off-State Leakage Current @ Rated Voltage [mA_{rms}]	0.1	0.1	0.1
Minimum Off-State dv/dt @ Maximum Rated Voltage [$\text{V}/\mu\text{sec}$] ²	500	500	500
Maximum Load Current [A_{rms}]	5	5	5
Minimum Load Current [A_{rms}]	0.06	0.06	0.06
Maximum Surge Current (16.6msec) [Apk]	250	250	250
Maximum On-State Voltage Drop @ Rated Current [Vpk]	1.4	1.4	1.4
Maximum $I^2 t$ for Fusing (8.3msec) [$\text{A}^2 \text{sec}$]	260	260	260
Minimum Power Factor (at Maximum load)	0.5	0.5	0.5
HP rating UL 508/IEC60947[HP/KW]: 240VAC	0.25/0.18	0.25/0.18	0.25/0.18
HP rating UL 508/IEC60947[HP/KW]: 380VAC	NA	0.33/0.25	0.33/0.25
HP rating UL 508/IEC60947[HP/KW]: 480VAC	NA	NA	0.5/0.37

Input ⁽¹⁾

Description	CX240Dx	CX380/480Dx	CXE _{xxx} Dx	CX240A5	CXE240A5
Nominal Voltage	5 VDC	5 VDC	24 VDC	120 VAC	24 VAC
Control Voltage Range	3-15 VDC	4-15 VDC	15-32 VDC	90-140 VAC	18-36 VAC
Minimum Turn-On Voltage	3.0 VDC	4.0 VDC	15.0 VDC	90.0 Vrms	18.0 Vrms
Drop Out Voltage	1.0 VDC	1.0 VDC	1.0 VDC	10.0 Vrms	2.0 Vrms
Typical Input Current	15 mAdc	15 mAdc	15 mAdc	10mArms	10mArms
Nominal Input Impedance	300 Ohm	240 Ohm	1500 Ohm	14.1K Ohm	2.1K Ohm
Maximum Turn-On Time [msec] ³	1/2 Cycle	1/2 Cycle	1/2 Cycle	10	10
Maximum Turn-Off Time [msec]	1/2 Cycle	1/2 Cycle	1/2 Cycle	40	40

General ⁽¹⁾

Description	Parameters
Dielectric Strength, Input/Output (50/60Hz)	4000 Vrms
Minimum Insulation Resistance (@ 500 VDC)	10^9 Ohm
Maximum Capacitance, Input/Output	10 pF
Ambient Operating Temperature Range	-10°C to 80°C
Ambient Storage Temperature Range	-10°C to 125°C
Weight (typical)	0.4 oz (11g)
Encapsulation	Thermally Conductive Epoxy
Enclosure and PCB	Meets the requirements of IEC60335-1

WIRING DIAGRAMS

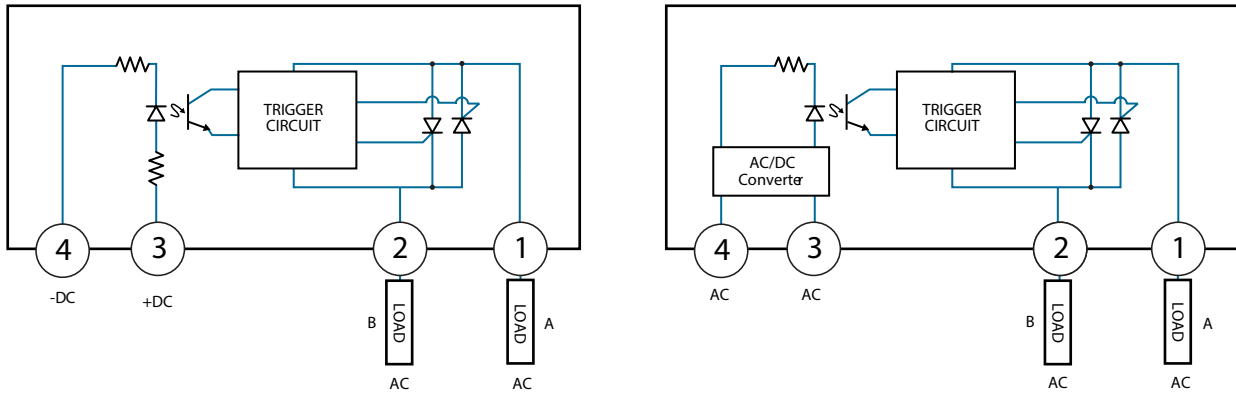

Load can be wired in location A or B

MECHANICAL SPECIFICATIONS

Tolerances: ± 0.02 in / 0.5 mm

All dimensions are in: inches [millimeters]

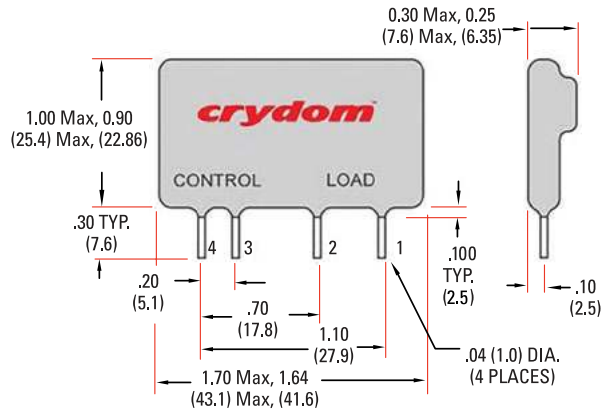

THERMAL DERATE INFORMATION

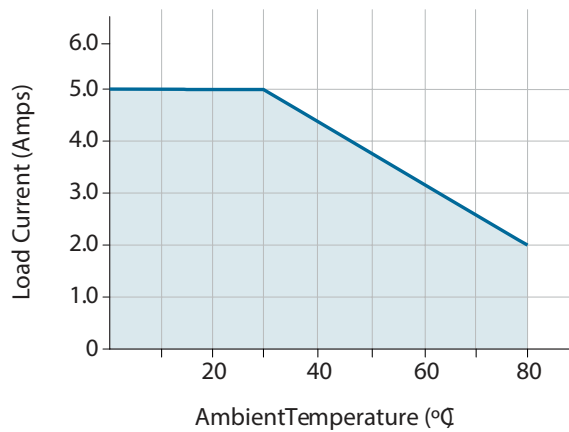

ORDERING OPTIONS

Example : CXE240D5R

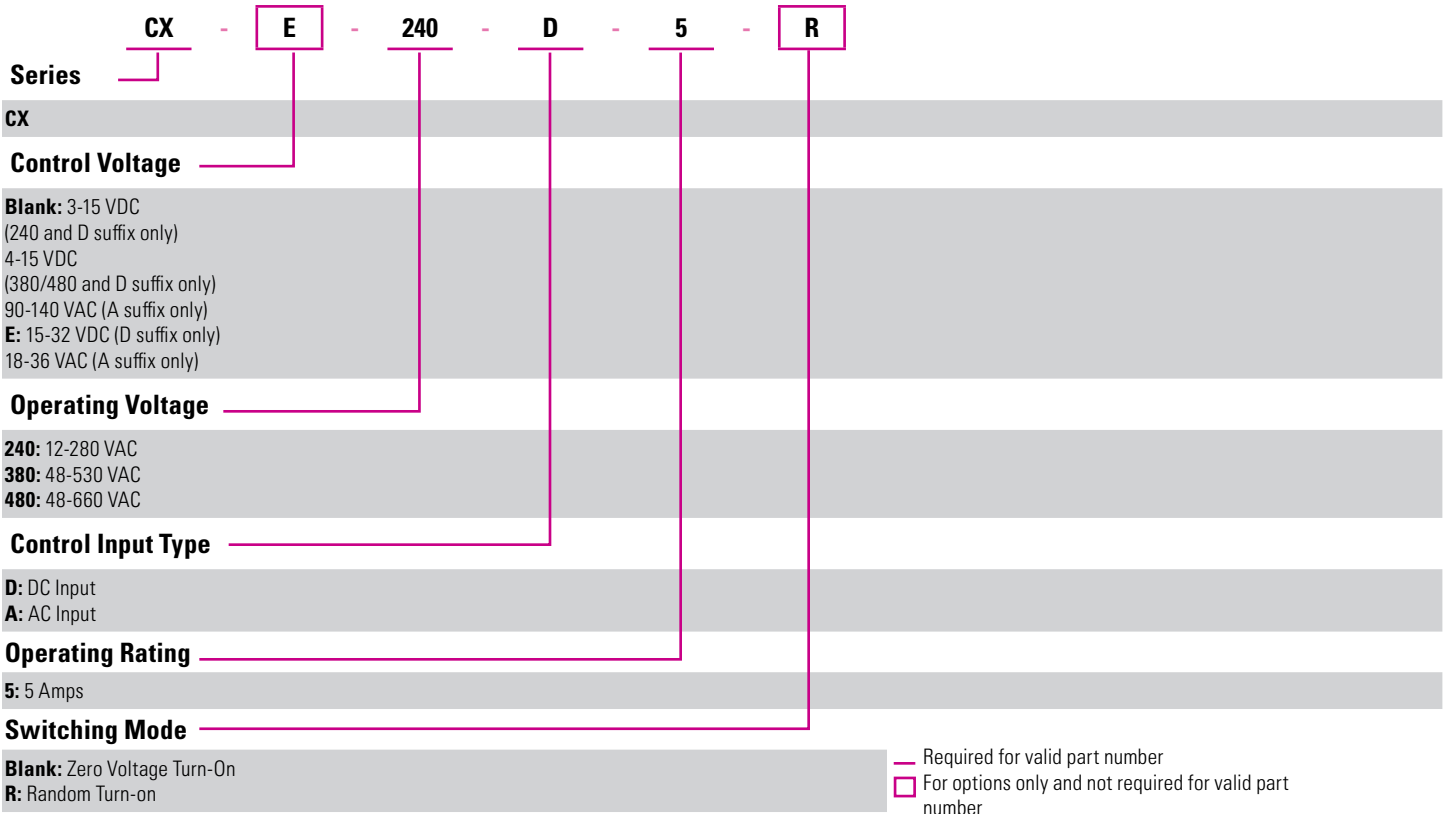

GENERAL NOTES

- (1) All parameters at 25°C unless otherwise specified
- (2) Off-State dv/dt test method per EIA/NARM standard RS-443, paragraph 13.11.1
- (3) Turn-On time for random turn-on versions is 0.01 msec (DC control Models)

AGENCY APPROVALS & CERTIFICATIONS

Designed in accordance with the requirements of IEC 62314
 CE EN60950 : Meets the requirements of sections 1.5: 1.7: 2.9: 2.10.5.3: 4.2: 4.5: 4.7
 IEC60335-1: Resistance to heat and fire meets the requirements of section 30, evaluated by TUV SUD.
 Glow Wire Test, per requirements of IEC/EN 60695-2-10 and IEC/EN 60695-2-11
 Ball Pressure Test, per requirements of IEC/EN 60695-10-2



WARNINGS



RISK OF MATERIAL DAMAGE AND HOT ENCLOSURE

- The product's side panels may be hot, allow the product to cool before touching
- Follow proper mounting instructions including torque values
- Do not allow liquids or foreign objects to enter this product

Failure to follow these instructions can result in serious injury, or equipment damage.



HAZARD OF ELECTRIC SHOCK, EXPLOSION OR ARC FLASH

- Disconnect all power before installing or working with this equipment
- Verify all connections and replace all covers before turning on power

Failure to follow these instructions will result in death or serious injury.

Datasheets provided by Sensata Technologies, Inc., its subsidiaries and/or affiliates ("Sensata") are solely intended to assist third parties ("Buyers") who are developing systems that incorporate Sensata products (also referred to herein as "components"). Buyer understands and agrees that Buyer remains responsible for using its independent analysis, valuation, and judgment in designing Buyer's systems and products. Sensata datasheets have been created using standard laboratory conditions and engineering practices. Sensata has not conducted any testing other than that specifically described in the published documentation for a particular datasheet. Sensata may make corrections, enhancements, improvements, and other changes to its datasheets or components without notice.

Buyers are authorized to use Sensata datasheets with the Sensata component(s) identified in each particular datasheet. HOWEVER, NO OTHER LICENSE, EXPRESS OR IMPLIED, BY ESTOPPEL OTHERWISE TO ANY OTHER SENSATA INTELLECTUAL PROPERTY RIGHT, AND NO LICENSE TO ANY THIRD PARTY TECHNOLOGY OR INTELLECTUAL PROPERTY RIGHT, IS GRANTED HEREIN. SENSATA DATASHEETS ARE PROVIDED "AS IS". SENSATA MAKES NO WARRANTIES OR REPRESENTATIONS WITH REGARD TO THE DATASHEETS OR USE OF THE DATASHEETS, EXPRESS, IMPLIED, OR STATUTORY, INCLUDING ACCURACY OR COMPLETENESS. SENSATA DISCLAIMS ANY WARRANTY OF TITLE AND ANY IMPLIED WARRANTIES OF MERCHANTABILITY, FITNESS FOR A PARTICULAR PURPOSE, QUIET ENJOYMENT, QUIET POSSESSION, AND NON-INFRINGEMENT OF ANY THIRD PARTY INTELLECTUAL PROPERTY RIGHTS WITH REGARD TO SENSATA DATASHEETS OR USE THEREOF.

All products are sold subject to Sensata's terms and conditions of sale supplied at www.sensata.com. SENSATA ASSUMES NO LIABILITY FOR APPLICATIONS ASSISTANCE OR THE DESIGN OF BUYERS' PRODUCTS. BUYER ACKNOWLEDGES AND AGREES THAT IT IS SOLELY RESPONSIBLE FOR COMPLIANCE WITH ALL LEGAL, REGULATORY, AND SAFETY-RELATED REQUIREMENTS CONCERNING ITS PRODUCTS, AND ANY USE OF SENSATA COMPONENTS IN ITS APPLICATIONS, NOTWITHSTANDING ANY APPLICATIONS-RELATED INFORMATION OR SUPPORT THAT MAY BE PROVIDED BY SENSATA.

Mailing Address: Sensata Technologies, Inc., 529 Pleasant Street, Attleboro, MA 02703, USA

CONTACT US

Americas

+1 (877) 502 5500 – Option 2
sales.crydom@sensata.com

Europe, Middle East & Africa

+44 (1202) 416170
ssr-info.eu@sensata.com

Asia Pacific

sales.isasia@list.sensata.com
China +86 (21) 2306 1500
Japan +81 (45) 277 7117
Korea +82 (31) 601 2004
India +91 (80) 67920890
Rest of Asia +886 (2) 27602006
ext 2808