



MICROCHIP

EQCO875SC.3/EQCO850SC.3

EQCO875SC.3/EQCO850SC.3 Single-Coax Transceiver for Fast Ethernet

Features

- Combined Transmitter and Receiver with an Integrated Equalizer to Form a Full-Duplex Bidirectional Connection over a Single 75Ω Coax Cable (EQCO875SC.3) or 50Ω Coax Cable (EQCO850SC.3)
- Compatible with FX Version of Fast Ethernet
- Low-Power: 205 mW from Single 3.3V Supply
- Integrated Termination Resistors for Low External Discrete Count
- Fully Supports PoE-Based Power and Data Signal Distribution Over Coax
- 16-Pin, 0.65 mm Pin Pitch, 4 mm QFN Package
- Pb-Free and RoHS Compliant

Applications

This solution is useful and economical for many markets and applications, including the following:

- Camera Networks
 - Home Security, Surveillance, Industrial/ Inspection, Medical Cameras
- Home Networking over Coax Infrastructure
 - When Cat5 or Cat6 cabling is not available and existing 75Ω coax is not used for analog TV signals
- TV, STB, PVR Connections Including Inter-Room Links

TABLE 1: TYPICAL DEVICE PERFORMANCE FOR EQCO875SC.3

Version	EQCO875SC.3 Range Using	
	RG11	RG6 (Ø 5 mm)
EQCO875SC.3	225m	150m

TABLE 2: TYPICAL DEVICE PERFORMANCE FOR EQCO850SC.3

Version	EQCO850SC.3 Range Using		
	RG174	RTK	RG58
EQCO850SC.3	40m	70m	70m

EQCO875SC.3/EQCO850SC.3

Table of Contents

1.0 Device Overview	3
2.0 Application Information	7
3.0 Electrical Characteristics	9
4.0 Packaging	11

TO OUR VALUED CUSTOMERS

It is our intention to provide our valued customers with the best documentation possible to ensure successful use of your Microchip products. To this end, we will continue to improve our publications to better suit your needs. Our publications will be refined and enhanced as new volumes and updates are introduced.

If you have any questions or comments regarding this publication, please contact the Marketing Communications Department via E-mail at docerrors@microchip.com. We welcome your feedback.

Most Current Data Sheet

To obtain the most up-to-date version of this data sheet, please register at our Worldwide Web site at:

<http://www.microchip.com>

You can determine the version of a data sheet by examining its literature number found on the bottom outside corner of any page. The last character of the literature number is the version number, (e.g., DS30000000A is version A of document DS30000000).

Errata

An errata sheet, describing minor operational differences from the data sheet and recommended workarounds, may exist for current devices. As device/documentation issues become known to us, we will publish an errata sheet. The errata will specify the revision of silicon and revision of document to which it applies.

To determine if an errata sheet exists for a particular device, please check with one of the following:

- Microchip's Worldwide Web site; <http://www.microchip.com>
- Your local Microchip sales office (see last page)

When contacting a sales office, please specify which device, revision of silicon and data sheet (include literature number) you are using.

Customer Notification System

Register on our web site at www.microchip.com to receive the most current information on all of our products.

1.0 DEVICE OVERVIEW

The EQCO875SC.3 single-coax transceiver is designed to simultaneously transmit and receive signals on a single 75Ω coax cable for Fast Ethernet. A sister product, the EQCO850SC.3, can achieve similar performance when used in 50Ω coaxial systems.

The EQCO875SC.3 is ideally suited for Fast Ethernet connections over a 75Ω coax cable at a 125 Mbps data rate. The EQCO875SC.3 connects seamlessly to any FX-compliant physical layer controller (PHY). For correct operation, the signals are expected to be 4B/5B encoded, DC balanced and to have a bit rate of 125 Mbps.

This EQCO875SC.3 is useful and economical for connecting remote PoE-enabled Fast Ethernet IP cameras and other Ethernet over Coax applications.

Figure 1-1 illustrates a typical Ethernet Coaxial connection:

FIGURE 1-1: COAXIAL ETHERNET PMD CONNECTION

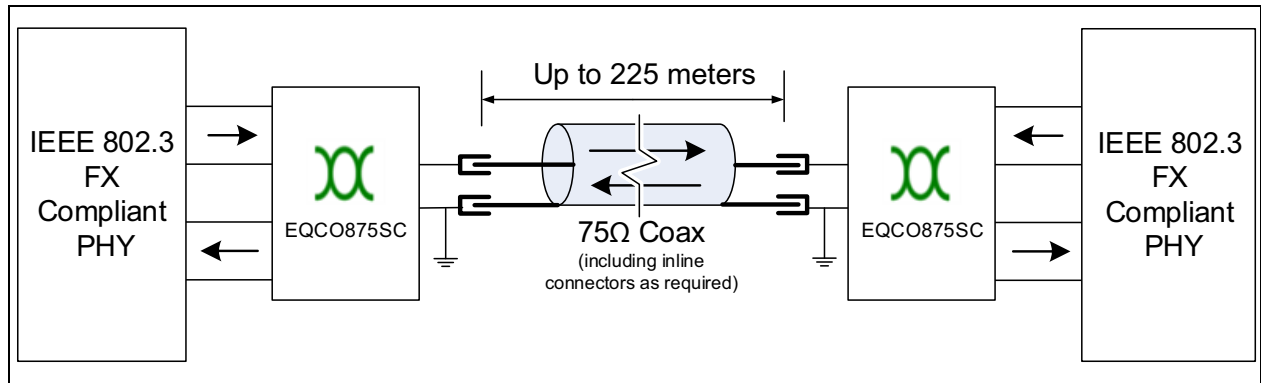

EQCO875SC.3/EQCO850SC.3

FIGURE 1-2: EQCO875SC.3 PIN DIAGRAM (VIEWED FROM TOP)⁽¹⁾

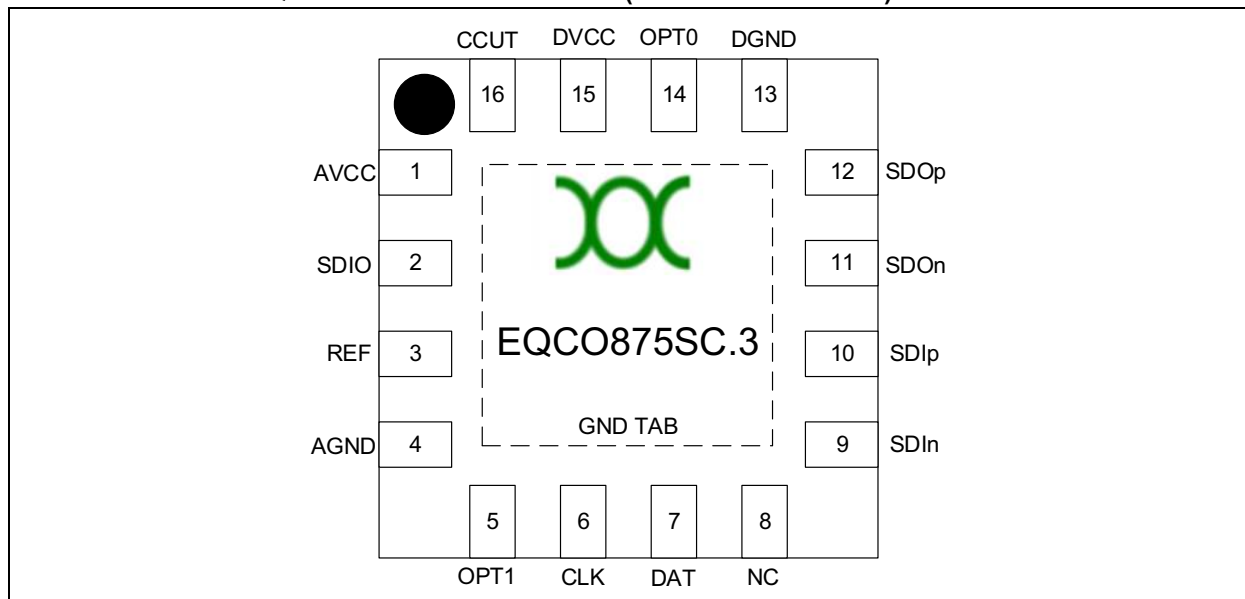

Note 1: Devices named EQCO850SC.2 can be used for all applications contained in this data sheet. They are the same in all aspects.

TABLE 1-1: EQCO875SC.3 PIN DESCRIPTIONS

Pin Number	Pin Name	Signal Type	Description
(TAB)	GND	Power	Connect to ground of power supply.
15	DVCC	Power	Digital VCC. Connect to +3.3V of power supply.
13	DGND	Power	Digital GND. Connect to ground of power supply.
1	AVCC	Power	Analog VCC. Connect to +3.3V of power supply via ferrite bead (RF choke) and capacitor to cable outer screen.
4	AGND	Power	Analog GND. Connect to cable outer screen.
2	SDIO	Bidirectional	Serial Input/Output. Connect to center conductor of 75Ω coax cable.
3	REF	Bidirectional	Reference. Connect through 75Ω resistor (or impedance matched to cable) to cable outer screen.
8	NC	Output	Do not connect.
10, 9	SDIp/SDIn	Input	Positive/negative differential serial input. Connect to the Ethernet PHY FX Out pins.
12, 11	SDOp/SDOn	Output	Positive/negative differential serial output. Connect to the Ethernet PHY FX In pins.
14, 5	OPT0, OPT1	Input	Connect Opt0 to DGND and Opt1 to DVCC to enable Fast Ethernet mode.
6, 7	CLK, DAT	Input	Used for production test. Connect to DGND.
16	CCUT	Analog	Connect to DVCC.

EQCO875SC.3/EQCO850SC.3

FIGURE 1-3: EQCO875SC.3 BLOCK DIAGRAM SHOWING ELECTRICAL CONNECTIONS

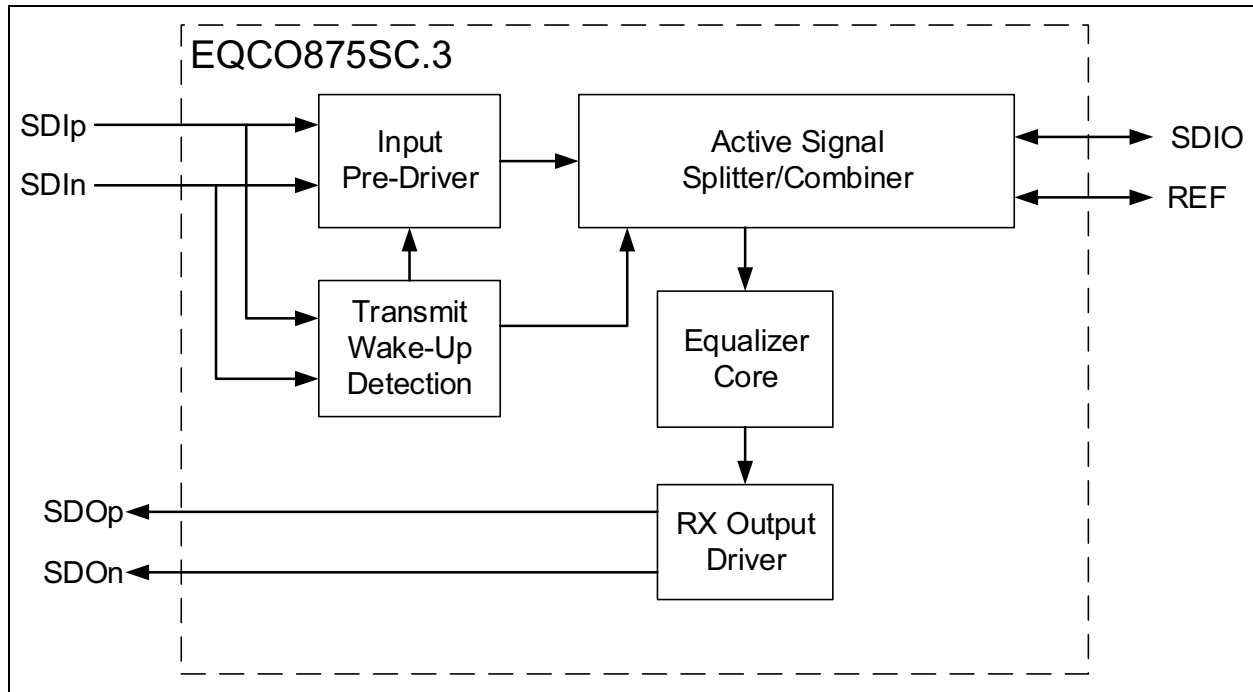

1.1 SDIp/SDIn

SDIp/SDIn together form a differential input pair. The serial data received on these pins will be transmitted on SDIO. The Input Pre-Driver automatically corrects for variations in signal levels and different edge slew rates at these inputs before they go into the Active Splitter/Combiner for transmission over the coax.

Both SDIp and SDIn inputs are differentially terminated by 110Ω on-chip. The center of the 110Ω is connected to DGND with a 10 kΩ resistor for DC biasing. The inputs also have protection diodes to ground for ESD purposes. These inputs should always be capacitively coupled to the FX output of the Ethernet PHY. A Transmit Wake-Up detection circuit puts both the Input Pre-Driver and the Active Signal Splitter/Combiner into a low-power mode when no signal is detected on the SDIp/SDIn signal pair.

1.2 SDIO/REF

The signal on the SDIO pin is the sum of the incoming signal (i.e. the signal transmitted by the EQCO875SC on the far-end side of the coax) and the outgoing signal (i.e. the signal created based on SDIp/SDIn). The far-end signal is extracted by subtraction of the near-end signal, and it is this voltage that the equalizer analyses and adaptively equalizes for level and frequency response based on the knowledge that the originating signal is 4B/5B encoded before transmission.

The REF signal carries a precise anti-phase current to the transmit current on SDIO. REF must be connected directly to AGND at the connector (see Figure 3-2) via a resistor precisely matched to the impedance of the coaxial cable used.

1.3 SDOp/SDOn

SDOp/SDOn together form a differential pair outputting the reconstructed far-end transmit signal. The EQCO850SC-HS uses LVDS drivers with source matching for a 100Ω transmission line. This LVDS signal can normally be connected (subject to input common-mode requirements) directly to the RX signal pair of a standard LVDS receiver.

1.4 OPT0, OPT1

Connect Opt0 to DGND and Opt1 to DVCC to enable Fast Ethernet mode.

1.5 CLK, DAT Pins

These pins are normally used to access an internal register during production test. Connect them to DGND for normal operation. They should not be left floating.

EQCO875SC.3/EQCO850SC.3

2.0 CIRCUIT OPERATION

2.1 Pre-Driver

The pre-driver removes any dependency on Ethernet PHY for the amplitude and rise time of the outgoing signal on SDIO.

2.2 Active Signal Splitter/Combiner

The Active Splitter/Combiner controls the amplitude and rise time of the outgoing coax signal and transmits it via a precise 75Ω output termination resistor. The output resistor, when balanced with the coax characteristic impedance, also forms part of a hybrid splitter circuit which subtracts the TX output from the signal on the SDIO output to give yield the far-end TX signal. The return-loss of the coax termination is a key factor in the performance of the line hybrid.

2.3 Equalizer Core

The EQCO875SC-HS has an embedded high-speed equalizer in the receive path with unique characteristics:

- Auto-adaptive

The equalizer controls a multiple-pole analog filter which compensates for attenuation of the cable, as illustrated in Figure 2-1. The filter frequency response needed to restore the signal is automatically determined by the device using a time-continuous feedback loop that measures the frequency components in the signal. Upon the detection of a valid signal, the control loop converges within a few microseconds.

- Variable gain

EQCO875SCs are used in pairs, with one at each end of the coax cable. The EQCO875SC can be used with any Fast Ethernet compliant fiber optic PHY; any differences in transmit amplitude are removed by the input pre-driver. The receiver equalizer has variable gain to compensate for attenuation through the coax cable.

FIGURE 2-1: PRINCIPLE OF EQUALIZER OPERATION

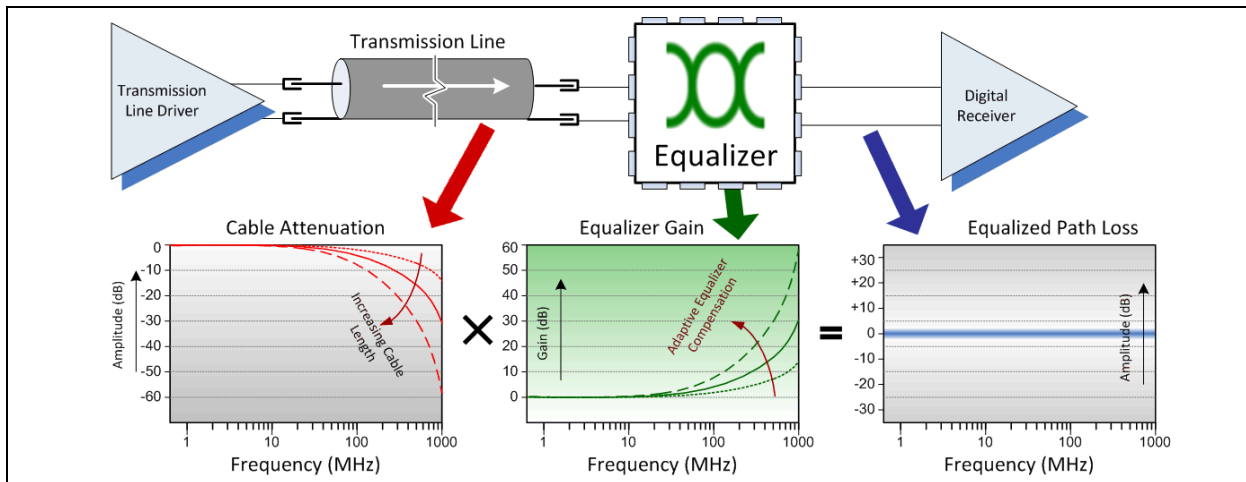

3.0 APPLICATION INFORMATION

Figure 3-1 illustrates a typical schematic implementation for the EQCO875SC.3 in Ethernet mode.

FIGURE 3-1: EQCO875SC.3 TYPICAL APPLICATION CIRCUIT

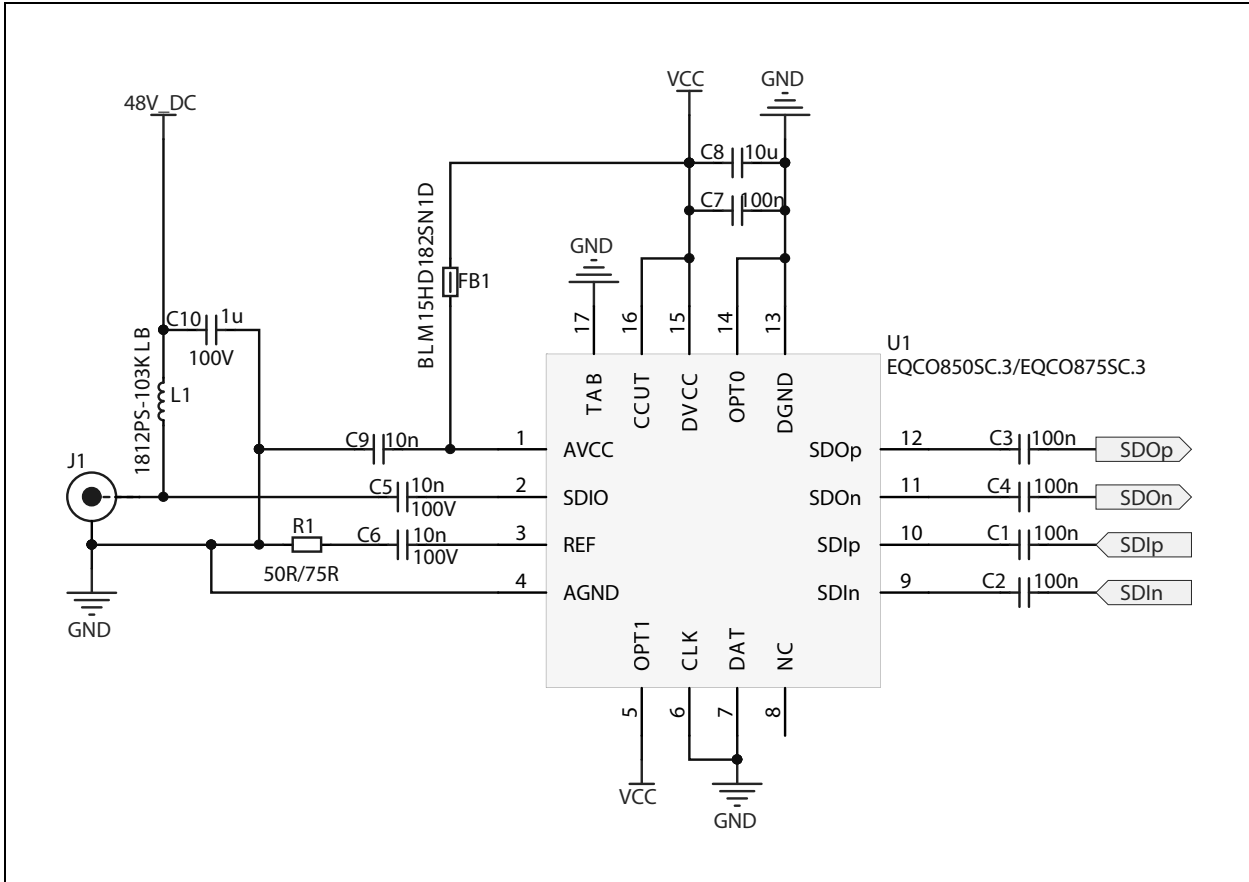

To improve isolation from noise on the board power plane and improve EMC immunity and emissions, it is recommended to power the transmit side of the equalizer (AVCC) through a ferrite bead (FB1). C9 is used to reference AVCC to the ground directly at the connector J1, while AGND is also connected directly to the connector.

A 100 nF decoupling capacitor (C7) should be placed as close as possible between the DVCC pin and the DGND pin. The REF and SDIO signals are AC-coupled with identical capacitors, C5 and C6. Termination resistor R1 should match the characteristic impedance of the system, 50Ω for EQCO850SC.3 and 75Ω for EQCO875SC.3.

A CoilCraft 1812PS-103KLB inductor (L1) is recommended for best performance when using power over coax. L1 and C10 can be removed if power over coax is not required.

EQCO875SC.3/EQCO850SC.3

3.1 Guidelines for PCB Layout

Because signals are strongly attenuated by long cables, special attention must be paid on the PCB layout between the coaxial connector and the EQCO875SC.3. The EQCO875SC.3 should be placed as close as is practical to the coaxial connector. The trace between the coaxial connector and the SDIO pin of the EQCO875SC.3 must be a 75Ω (50Ω for EQCO850SC.3) trace referenced to GND. To avoid noise pickup, other traces carrying digital signals or fast-switching signals should be placed as far away as possible from this trace.

The ground layout on the EQCO875SC.3 is crucial to the EMC and EMI performance of the circuit. The AGND connection should be connected directly to the body of the connector as shown. Similarly, AVCC

should be decoupled directly to the connector body (see the position of C9). The termination resistor (R1 in Figure 3-1 and Figure 3-2) must have its ground connection at the connector body. The impedance of all the traces must be well controlled, including on the connector itself. To compensate for parasitic capacitances, the ground and power planes underneath L1 and part of the coax connector need to be removed, as indicated by the green areas on Figure 3-2.

The SDIp/SDIn and SDOp/SDOn differential traces should be laid out as 100Ω differential traces.

The following diagram shows the layout of the critical section of the PCB corresponding to the circuit of Figure 3-1 from the coax connector to the twin differential pairs:

FIGURE 3-2: TYPICAL PCB LAYOUT

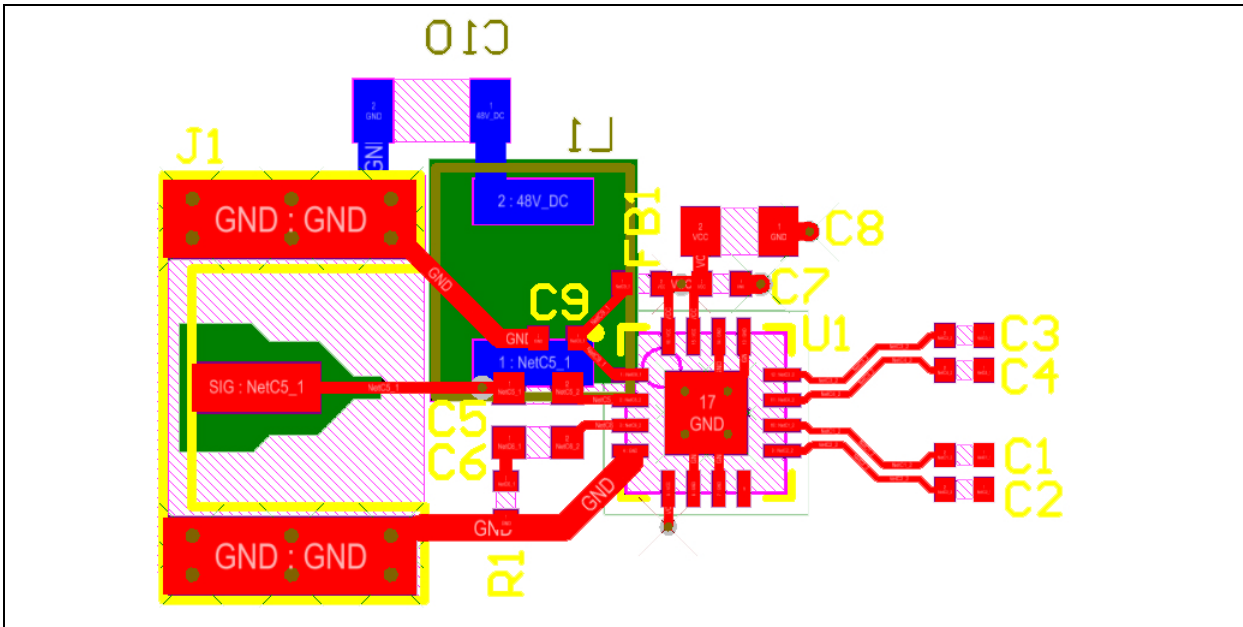

EQCO875SC.3/EQCO850SC.3

4.0 ELECTRICAL CHARACTERISTICS

4.1 Absolute Maximum Ratings

Stresses beyond those listed under this section may cause permanent damage to the device. These are stress ratings only and are not tested. Functional operation of the device at these or any other conditions beyond those indicated in the operational sections is not implied. Exposure to absolute maximum rating conditions for extended periods may affect device reliability.

TABLE 4-1: ABSOLUTE MAXIMUM RATINGS

Parameter	Min.	Typ.	Max.	Units	Conditions
Storage Temperature	-65	—	+150	°C	
Ambient Temperature	-55	—	+125	°C	Power Applied
Supply Voltage to Ground	-0.5	—	+4.0	V	
DC Input Voltage	-0.5	—	+4.0	V	
DC Voltage to Outputs	-0.5	—	+4.0	V	
Output Current into Outputs	—	—	90	mA	Outputs Low

TABLE 4-2: ELECTRICAL CHARACTERISTICS

Parameter	Min.	Typ.	Max.	Unit	Description
Power Supply					
V_{CC}	3.2	3.3	3.4	V	Supply voltage.
I_S	47.5	62.5	75.5	mA	Supply current, both transmitting and receiving.
I_{SR}	25	35	43	mA	Supply current when not transmitting.
SDIp/SDIn Input (LVDS-like)					
ΔV_i	250	—	800	mV	Input amplitude $V_{SDIp,n}$.
V_{turnon}	100	140	200	mV	Minimal ΔV_i to turn on transmit function.
V_{cmin}	—	0	—	V	Common-mode input voltage (terminated to ground with protection diodes).
R_{input}	85	104	115	Ω	Differential input termination.
SDIO Connection to Coax					
Z_{coax}	72 (48)	75 (50)	78 (52)	Ω	Required coax cable characteristic impedance.
R_{SDIO}	65 (46)	75 (51)	86 (55)	Ω	Input impedance between SDIO and AGND.
R_{loss}	20	—	—	dB	Coax return-loss as seen on SDIO pin. Frequency range = 10 MHz-62.5 MHz.
ΔV_{TX}	250	300	350	mV	Transmit amplitude.
t_{rise_tx}	350	450	550	ps	Rise/fall time 20% to 80% of ΔV_{TX} .
Att_{max}	—	10	—	dB	Cable attenuation budget @ 62.5 MHz.
ΔV_{RXmin}	—	40	—	mV	Minimum input for fully reconstructed output.

EQCO875SC.3/EQCO850SC.3

TABLE 4-2: ELECTRICAL CHARACTERISTICS (CONTINUED)

SDOp/SDOn Outputs (LVDS-like)					
ΔV_o	250	350	450	mV	Output amplitude $V_{SDOp,n}$.
V_{cmout}	1.1	1.2	1.3	V	Common-mode output voltage.
R_{output}	85	102	115	Ω	Differential termination between SDOp and SDOn.
t_{rise_o}	150	240	350	ps	Rise/fall time 20% to 80% of $V_{SDOp,n}$.

TABLE 4-3: JITTER PERFORMANCE

Parameter	Min.	Typ.	Max.	Units	Conditions
Jitter peak-to-peak on SDO	—	40%	50%	UI	150m RG6 coax; over full V_{CC} , ΔV_{TX} , and temp range; 125 Mbps; pattern PRBS7

TABLE 4-4: TEMPERATURE SPECIFICATIONS

Parameter	Symbol	Min.	Typ.	Max.	Unit
Temperature Ranges					
Operating Ambient Temperature	T_A	-10	—	70	$^{\circ}\text{C}$
Operating Junction Temperature	T_J	-10	—	85	$^{\circ}\text{C}$
Thermal Package Resistances					
Typical Junction to Package	Ψ_{JT}	—	1.2	—	$^{\circ}\text{C/W}$
Typical Junction to Ambient	Θ_{JA}	—	59	—	$^{\circ}\text{C/W}$
Typical Junction to Case	Θ_{JC}	—	10	—	$^{\circ}\text{C/W}$

5.0 PACKAGING INFORMATION

5.1 Package Marking Information

16-Lead Plastic Quad Flat, No Lead Package – 4x4x0.9 mm Body [QFN]

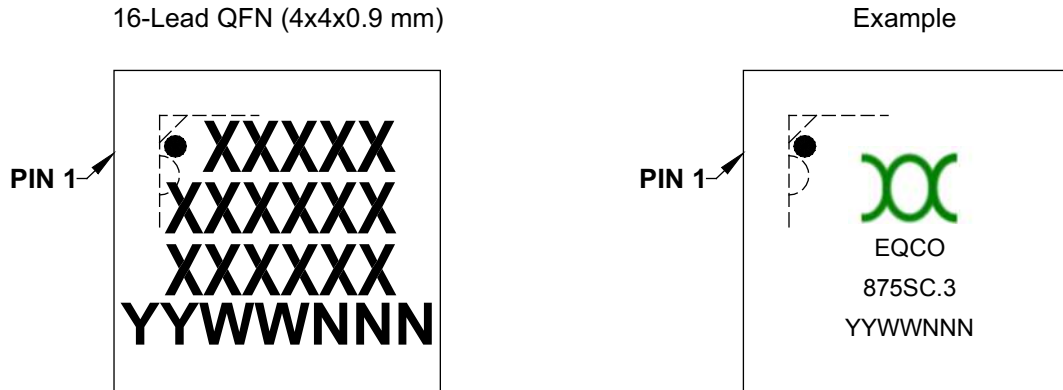

Legend: XX...X Part number
YY Year code (last 2 digits of calendar year)
WW Week code (week of January 1 is week '01')
NNN Alphanumeric traceability code (optional)
Pb-free JEDEC[®] designator for Matte Tin (Sn)
ⓔ3 This package is Pb-free. The Pb-free JEDEC designator () can be found on the outer packaging for this package. ⓔ3

Note: In the event the full Microchip part number cannot be marked on one line, it will be carried over to the next line, thus limiting the number of available characters for customer-specific information.

EQCO875SC.3/EQCO850SC.3

16-Lead Plastic Quad Flat, No Lead Package (8E) - 4x4x0.9 mm Body [QFN]

Note: For the most current package drawings, please see the Microchip Packaging Specification located at <http://www.microchip.com/packaging>

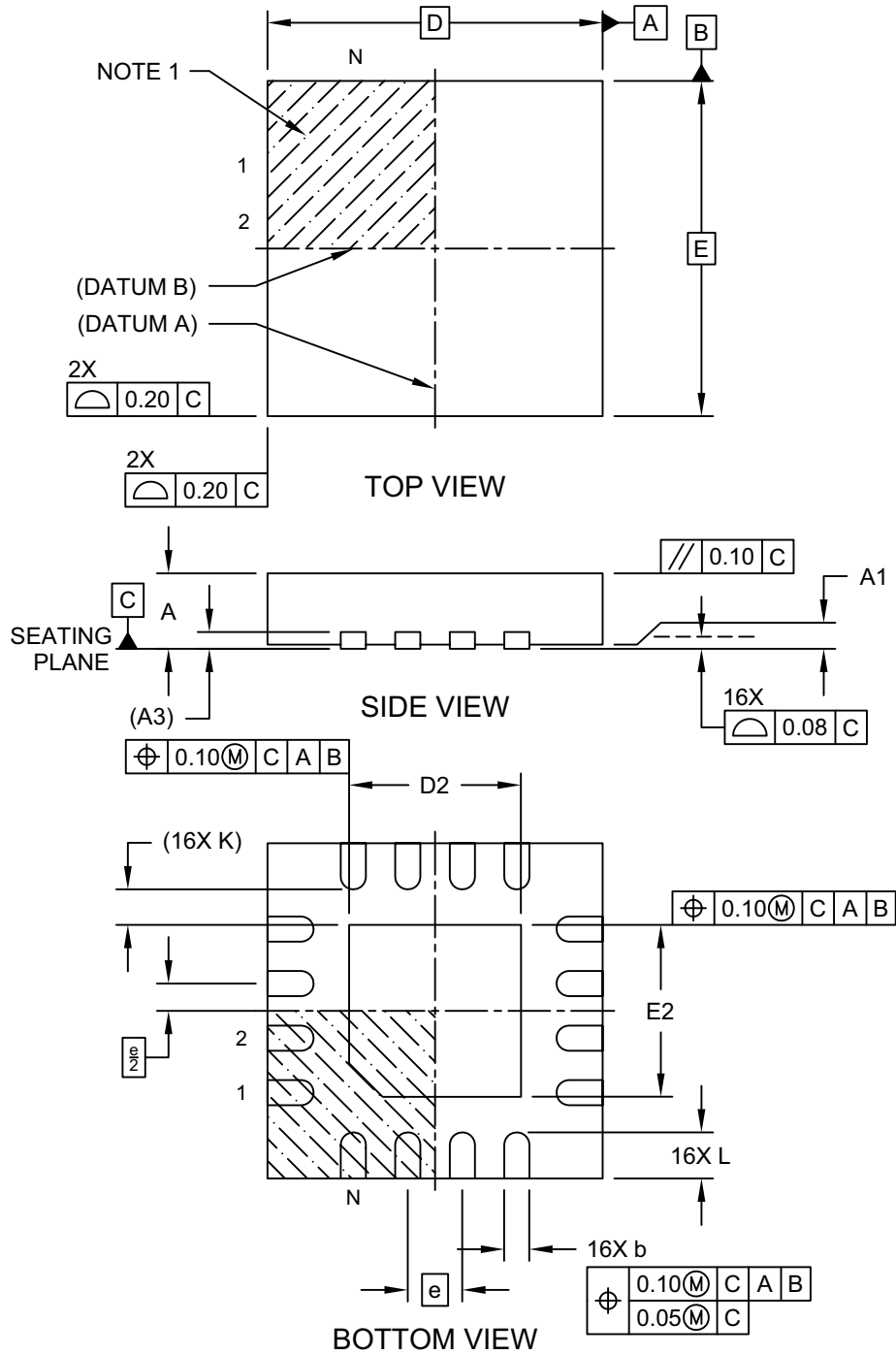

Microchip Technology Drawing C04-259B Sheet 1 of 2

EQCO875SC.3/EQCO850SC.3

16-Lead Plastic Quad Flat, No Lead Package (8E) - 4x4x0.9 mm Body [QFN]

Note: For the most current package drawings, please see the Microchip Packaging Specification located at <http://www.microchip.com/packaging>

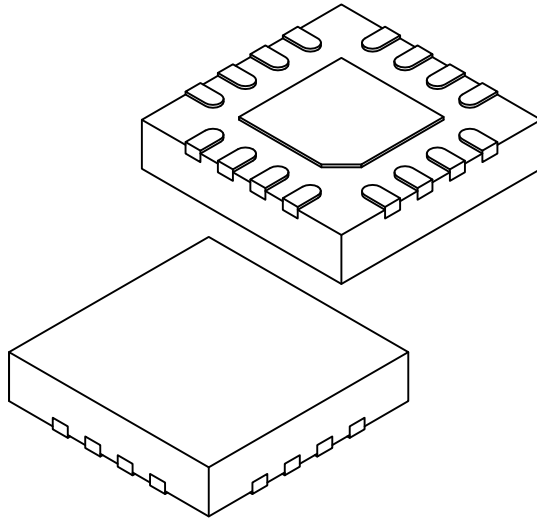

Dimension Limits	Units	MILLIMETERS		
		MIN	NOM	MAX
Number of Pins	N	16		
Pitch	e	0.65 BSC		
Overall Height	A	0.80	0.87	0.95
Standoff	A1	0.00	0.02	0.05
Terminal Thickness	A3	0.20 REF		
Overall Width	E	4.00 BSC		
Exposed Pad Width	E2	1.95	2.05	2.15
Overall Length	D	4.00 BSC		
Exposed Pad Length	D2	1.95	2.05	2.15
Terminal Width	b	0.25	0.30	0.35
Terminal Length	L	0.45	0.55	0.65
Terminal-to-Exposed-Pad	K	0.425 REF		

Notes:

1. Pin 1 visual index feature may vary, but must be located within the hatched area.
2. Package is saw singulated
3. Dimensioning and tolerancing per ASME Y14.5M
BSC: Basic Dimension. Theoretically exact value shown without tolerances.
REF: Reference Dimension, usually without tolerance, for information purposes only.

Microchip Technology Drawing C04-259B Sheet 2 of 2

EQCO875SC.3/EQCO850SC.3

16-Lead Plastic Quad Flat, No Lead Package (8E) - 4x4x0.9 mm Body [QFN]

Note: For the most current package drawings, please see the Microchip Packaging Specification located at <http://www.microchip.com/packaging>

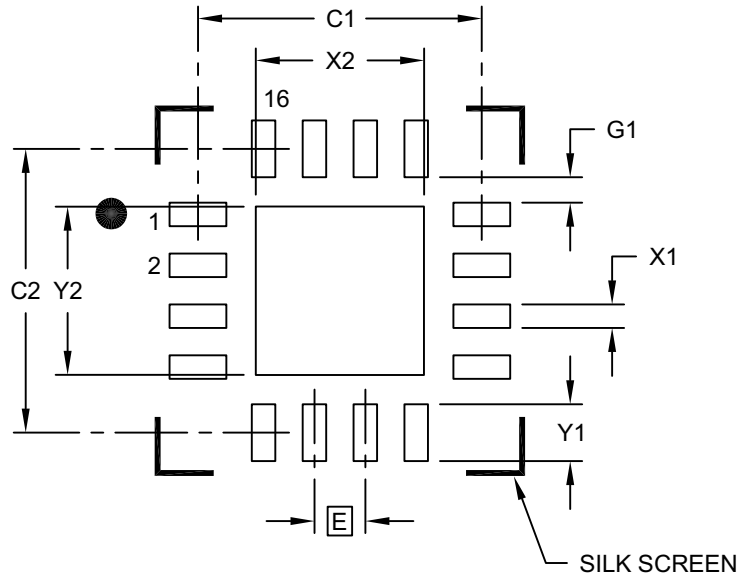

RECOMMENDED LAND PATTERN

Dimension Limits	Units	MILLIMETERS		
		MIN	NOM	MAX
Contact Pitch	E	0.65 BSC		
Optional Center Pad Width	X2			2.15
Optional Center Pad Length	Y2			2.15
Contact Pad Spacing	C1		3.625	
Contact Pad Spacing	C2		3.625	
Contact Pad Width (X16)	X1			0.30
Contact Pad Length (X16)	Y1			0.725
Contact Pad to Center Pad (X16)	G1	0.20		

Notes:

1. Dimensioning and tolerancing per ASME Y14.5M

BSC: Basic Dimension. Theoretically exact value shown without tolerances.

Microchip Technology Drawing C04-2259A

APPENDIX A: REVISION HISTORY

Revision A (April 2016)

This is the initial release of the document in the Microchip format. This replaces EqcoLogic document version 2.0.

TABLE A-1: REVISION HISTORY

Version	Date	Comments
2v0	1/28/14	Merged 50Ω and 75Ω systems into one data sheet.
1v2	10/25/11	Fixed lower temperature limit.
1v1	6/8/11	Fixed bitrate, temperature range, SDIP/SDIN descriptions.
0v4	2/28/11	Internal quality review. Removed Preliminary status.
0v3	10/26/09	Technical review. Revised Section 5.1
0v2	10/15/09	Internal review.
0v1	10/15/09	Modified from EQCO875SC IEEE1394 data sheet.

EQCO875SC.3/EQCO850SC.3

NOTES:

THE MICROCHIP WEB SITE

Microchip provides online support via our web site at www.microchip.com. This web site is used as a means to make files and information easily available to customers. Accessible by using your favorite Internet browser, the web site contains the following information:

- **Product Support** – Data sheets and errata, application notes and sample programs, design resources, user's guides and hardware support documents, latest software releases and archived software
- **General Technical Support** – Frequently Asked Questions (FAQs), technical support requests, online discussion groups, Microchip consultant program member listing
- **Business of Microchip** – Product selector and ordering guides, latest Microchip press releases, listing of seminars and events, listings of Microchip sales offices, distributors and factory representatives

CUSTOMER CHANGE NOTIFICATION SERVICE

Microchip's customer notification service helps keep customers current on Microchip products. Subscribers will receive e-mail notification whenever there are changes, updates, revisions or errata related to a specified product family or development tool of interest.

To register, access the Microchip web site at www.microchip.com. Under "Support", click on "Customer Change Notification" and follow the registration instructions.

CUSTOMER SUPPORT

Users of Microchip products can receive assistance through several channels:

- Distributor or Representative
- Local Sales Office
- Field Application Engineer (FAE)
- Technical Support

Customers should contact their distributor, representative or field application engineer (FAE) for support. Local sales offices are also available to help customers. A listing of sales offices and locations is included in the back of this document.

Technical support is available through the web site at: <http://microchip.com/support>

EQCO875SC.3/EQCO850SC.3

PRODUCT IDENTIFICATION SYSTEM

To order parts, including industrial, or obtain information, for e.g., on pricing or delivery, refer to the factory or the listed sales office.

<u>PART NO.</u>	<u>XXXX</u>
Device	Package
Device:	EQCO875SC.3 EQCO850SC.3
Package:	TRAY = Tray "blank" = Tube

Examples:

- a) EQCO875SC.3-TRAY = 75Ω Coax,
Industrial temperature,
16-Lead QFN package,
Tray packaging
- b) EQCO850SC.3 = 50Ω Coax,
Industrial temperature,
16-Lead QFN package,
Tube packaging

Note the following details of the code protection feature on Microchip devices:

- Microchip products meet the specification contained in their particular Microchip Data Sheet.
- Microchip believes that its family of products is one of the most secure families of its kind on the market today, when used in the intended manner and under normal conditions.
- There are dishonest and possibly illegal methods used to breach the code protection feature. All of these methods, to our knowledge, require using the Microchip products in a manner outside the operating specifications contained in Microchip's Data Sheets. Most likely, the person doing so is engaged in theft of intellectual property.
- Microchip is willing to work with the customer who is concerned about the integrity of their code.
- Neither Microchip nor any other semiconductor manufacturer can guarantee the security of their code. Code protection does not mean that we are guaranteeing the product as “unbreakable.”

Code protection is constantly evolving. We at Microchip are committed to continuously improving the code protection features of our products. Attempts to break Microchip's code protection feature may be a violation of the Digital Millennium Copyright Act. If such acts allow unauthorized access to your software or other copyrighted work, you may have a right to sue for relief under that Act.

Information contained in this publication regarding device applications and the like is provided only for your convenience and may be superseded by updates. It is your responsibility to ensure that your application meets with your specifications. MICROCHIP MAKES NO REPRESENTATIONS OR WARRANTIES OF ANY KIND WHETHER EXPRESS OR IMPLIED, WRITTEN OR ORAL, STATUTORY OR OTHERWISE, RELATED TO THE INFORMATION, INCLUDING BUT NOT LIMITED TO ITS CONDITION, QUALITY, PERFORMANCE, MERCHANTABILITY OR FITNESS FOR PURPOSE. Microchip disclaims all liability arising from this information and its use. Use of Microchip devices in life support and/or safety applications is entirely at the buyer's risk, and the buyer agrees to defend, indemnify and hold harmless Microchip from any and all damages, claims, suits, or expenses resulting from such use. No licenses are conveyed, implicitly or otherwise, under any Microchip intellectual property rights unless otherwise stated.

Microchip received ISO/TS-16949:2009 certification for its worldwide headquarters, design and wafer fabrication facilities in Chandler and Tempe, Arizona; Gresham, Oregon and design centers in California and India. The Company's quality system processes and procedures are for its PIC® MCUs and dsPIC® DSCs, KEELOQ® code hopping devices, Serial EEPROMs, microperipherals, nonvolatile memory and analog products. In addition, Microchip's quality system for the design and manufacture of development systems is ISO 9001:2000 certified.

QUALITY MANAGEMENT SYSTEM
CERTIFIED BY DNV
== ISO/TS 16949 ==

Trademarks

The Microchip name and logo, the Microchip logo, AnyRate, dsPIC, FlashFlex, flexPWR, Heldo, JukeBlox, KeeLoq, KeeLoq logo, Klear, LANCheck, LINK MD, MediaLB, MOST, MOST logo, MPLAB, OptoLyzer, PIC, PICSTART, PIC32 logo, RightTouch, SpyNIC, SST, SST Logo, SuperFlash and UNI/O are registered trademarks of Microchip Technology Incorporated in the U.S.A. and other countries.

ClockWorks, The Embedded Control Solutions Company, ETHERSYNCH, Hyper Speed Control, HyperLight Load, IntelliMOS, mTouch, Precision Edge, and QUIET-WIRE are registered trademarks of Microchip Technology Incorporated in the U.S.A.

Analog-for-the-Digital Age, Any Capacitor, AnyIn, AnyOut, BodyCom, chipKIT, chipKIT logo, CodeGuard, dsPICDEM, dsPICDEM.net, Dynamic Average Matching, DAM, ECAN, EtherGREEN, In-Circuit Serial Programming, ICSP, Inter-Chip Connectivity, JitterBlocker, KlearNet, KlearNet logo, MiWi, motorBench, MPASM, MPF, MPLAB Certified logo, MPLIB, MPLINK, MultiTRAK, NetDetach, Omniscient Code Generation, PICDEM, PICDEM.net, PICkit, PICtail, PureSilicon, RightTouch logo, REAL ICE, Ripple Blocker, Serial Quad I/O, SQL, SuperSwitcher, SuperSwitcher II, Total Endurance, TSHARC, USBCheck, VariSense, ViewSpan, WiperLock, Wireless DNA, and ZENA are trademarks of Microchip Technology Incorporated in the U.S.A. and other countries.

SQTP is a service mark of Microchip Technology Incorporated in the U.S.A.

Silicon Storage Technology is a registered trademark of Microchip Technology Inc. in other countries.

GestIC is a registered trademarks of Microchip Technology Germany II GmbH & Co. KG, a subsidiary of Microchip Technology Inc., in other countries.

All other trademarks mentioned herein are property of their respective companies.

© 2009-2016, Microchip Technology Incorporated, Printed in the U.S.A., All Rights Reserved.

ISBN: 978-1-5224-0468-2



MICROCHIP

Worldwide Sales and Service

AMERICAS

Corporate Office
2355 West Chandler Blvd.
Chandler, AZ 85224-6199
Tel: 480-792-7200
Fax: 480-792-7277
Technical Support:
<http://www.microchip.com/support>
Web Address:
www.microchip.com

Atlanta
Duluth, GA
Tel: 678-957-9614
Fax: 678-957-1455

Austin, TX
Tel: 512-257-3370

Boston
Westborough, MA
Tel: 774-760-0087
Fax: 774-760-0088

Chicago
Itasca, IL
Tel: 630-285-0071
Fax: 630-285-0075

Cleveland
Independence, OH
Tel: 216-447-0464
Fax: 216-447-0643

Dallas
Addison, TX
Tel: 972-818-7423
Fax: 972-818-2924

Detroit
Novi, MI
Tel: 248-848-4000

Houston, TX
Tel: 281-894-5983

Indianapolis
Noblesville, IN
Tel: 317-773-8323
Fax: 317-773-5453

Los Angeles
Mission Viejo, CA
Tel: 949-462-9523
Fax: 949-462-9608

New York, NY
Tel: 631-435-6000

San Jose, CA
Tel: 408-735-9110

Canada - Toronto
Tel: 905-673-0699
Fax: 905-673-6509

ASIA/PACIFIC

Asia Pacific Office
Suites 3707-14, 37th Floor
Tower 6, The Gateway
Harbour City, Kowloon

Hong Kong
Tel: 852-2943-5100
Fax: 852-2401-3431

Australia - Sydney
Tel: 61-2-9868-6733
Fax: 61-2-9868-6755

China - Beijing
Tel: 86-10-8569-7000
Fax: 86-10-8528-2104

China - Chengdu
Tel: 86-28-8665-5511
Fax: 86-28-8665-7889

China - Chongqing
Tel: 86-23-8980-9588
Fax: 86-23-8980-9500

China - Dongguan
Tel: 86-769-8702-9880

China - Hangzhou
Tel: 86-571-8792-8115
Fax: 86-571-8792-8116

China - Hong Kong SAR
Tel: 852-2943-5100
Fax: 852-2401-3431

China - Nanjing
Tel: 86-25-8473-2460
Fax: 86-25-8473-2470

China - Qingdao
Tel: 86-532-8502-7355
Fax: 86-532-8502-7205

China - Shanghai
Tel: 86-21-5407-5533
Fax: 86-21-5407-5066

China - Shenyang
Tel: 86-24-2334-2829
Fax: 86-24-2334-2393

China - Shenzhen
Tel: 86-755-8864-2200
Fax: 86-755-8203-1760

China - Wuhan
Tel: 86-27-5980-5300
Fax: 86-27-5980-5118

China - Xian
Tel: 86-29-8833-7252
Fax: 86-29-8833-7256

ASIA/PACIFIC

China - Xiamen
Tel: 86-592-2388138
Fax: 86-592-2388130

China - Zhuhai
Tel: 86-756-3210040
Fax: 86-756-3210049

India - Bangalore
Tel: 91-80-3090-4444
Fax: 91-80-3090-4123

India - New Delhi
Tel: 91-11-4160-8631
Fax: 91-11-4160-8632

India - Pune
Tel: 91-20-3019-1500

Japan - Osaka
Tel: 81-6-6152-7160
Fax: 81-6-6152-9310

Japan - Tokyo
Tel: 81-3-6880-3770
Fax: 81-3-6880-3771

Korea - Daegu
Tel: 82-53-744-4301
Fax: 82-53-744-4302

Korea - Seoul
Tel: 82-2-554-7200
Fax: 82-2-558-5932 or
82-2-558-5934

Malaysia - Kuala Lumpur
Tel: 60-3-6201-9857
Fax: 60-3-6201-9859

Malaysia - Penang
Tel: 60-4-227-8870
Fax: 60-4-227-4068

Philippines - Manila
Tel: 63-2-634-9065
Fax: 63-2-634-9069

Singapore
Tel: 65-6334-8870
Fax: 65-6334-8850

Taiwan - Hsin Chu
Tel: 886-3-5778-366
Fax: 886-3-5770-955

Taiwan - Kaohsiung
Tel: 886-7-213-7828

Taiwan - Taipei
Tel: 886-2-2508-8600
Fax: 886-2-2508-0102

Thailand - Bangkok
Tel: 66-2-694-1351
Fax: 66-2-694-1350

EUROPE

Austria - Wels
Tel: 43-7242-2244-39
Fax: 43-7242-2244-393

Denmark - Copenhagen
Tel: 45-4450-2828
Fax: 45-4485-2829

France - Paris
Tel: 33-1-69-53-63-20
Fax: 33-1-69-30-90-79

Germany - Dusseldorf
Tel: 49-2129-3766400

Germany - Karlsruhe
Tel: 49-721-625370

Germany - Munich
Tel: 49-89-627-144-0
Fax: 49-89-627-144-44

Italy - Milan
Tel: 39-0331-742611
Fax: 39-0331-466781

Italy - Venice
Tel: 39-049-7625286

Netherlands - Drunen
Tel: 31-416-690399
Fax: 31-416-690340

Poland - Warsaw
Tel: 48-22-3325737

Spain - Madrid
Tel: 34-91-708-08-90
Fax: 34-91-708-08-91

Sweden - Stockholm
Tel: 46-8-5090-4654

UK - Wokingham
Tel: 44-118-921-5800
Fax: 44-118-921-5820

07/14/15