

REVISIONS				
P	LTR	DESCRIPTION	DATE	OWN APVD
R		REVISED PER ECO-16-017894	27APR2017	PHM CT

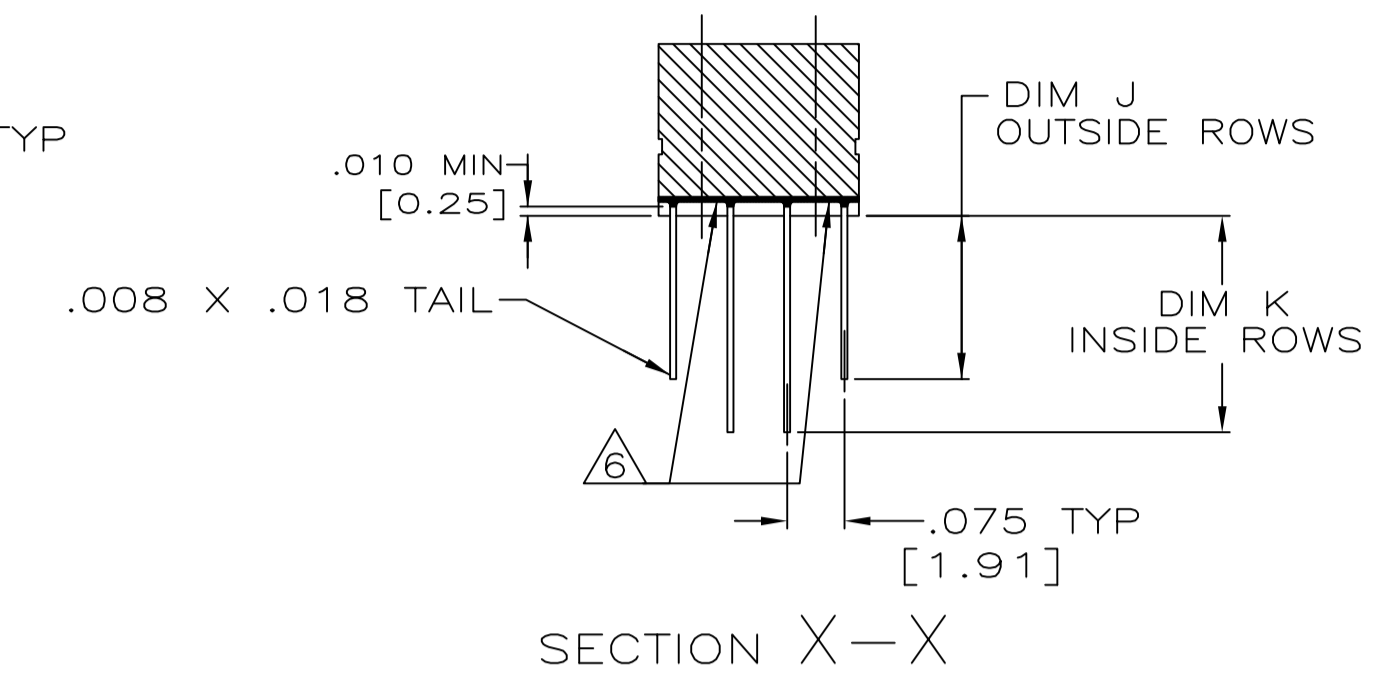

- 1 AMP, AMP PART NO. AND DATE CODE MARKED IN THIS APPROXIMATE AREA.
- 2 NUMBERS INDICATING END POSITIONS MARKED THIS SIDE ONLY.
- 3. MEETS ALL APPLICABLE REQUIREMENTS OF MIL-C-55302.
- 4 FINISH: .000050[0.0012] GOLD PER MIL-G-45204 OVER NICKEL PER QQ-N-290 IN CONTACT AREA. REMAINDER OF CONTACT TIN-LEAD OVER NICKEL.
- 5 HOUSING MATERIAL: LIQUID CRYSTAL POLYMER PER MIL-M-24519, GLCP-30F; COLOR: GRAY.
- 6 EPOXY IS ADDED TO BOTTOM OF HOUSING FOR INCREASED CONTACT RETENTION.
- 7 CONTACT MATERIAL: PHOS BRONZE PER QQ-B-750

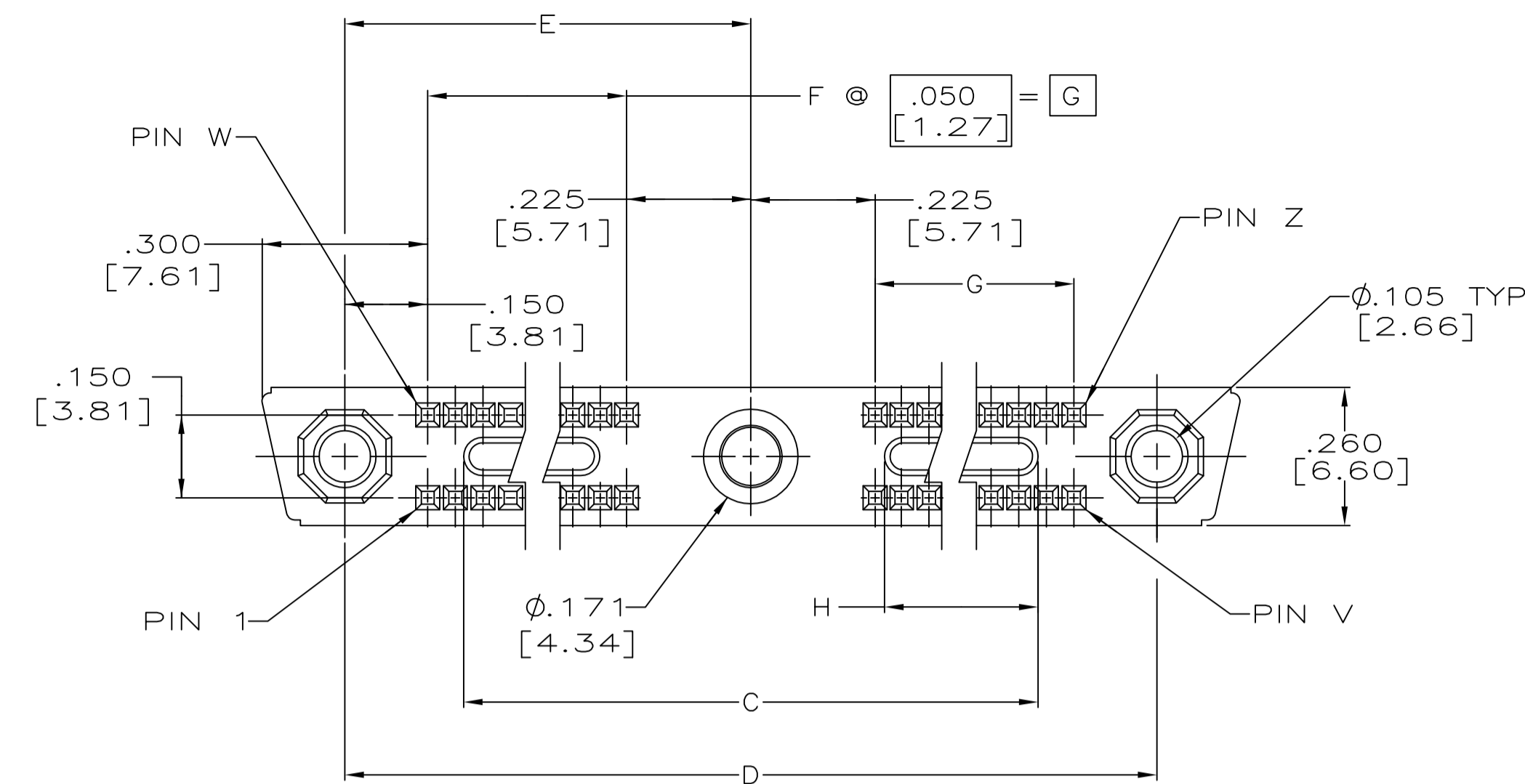
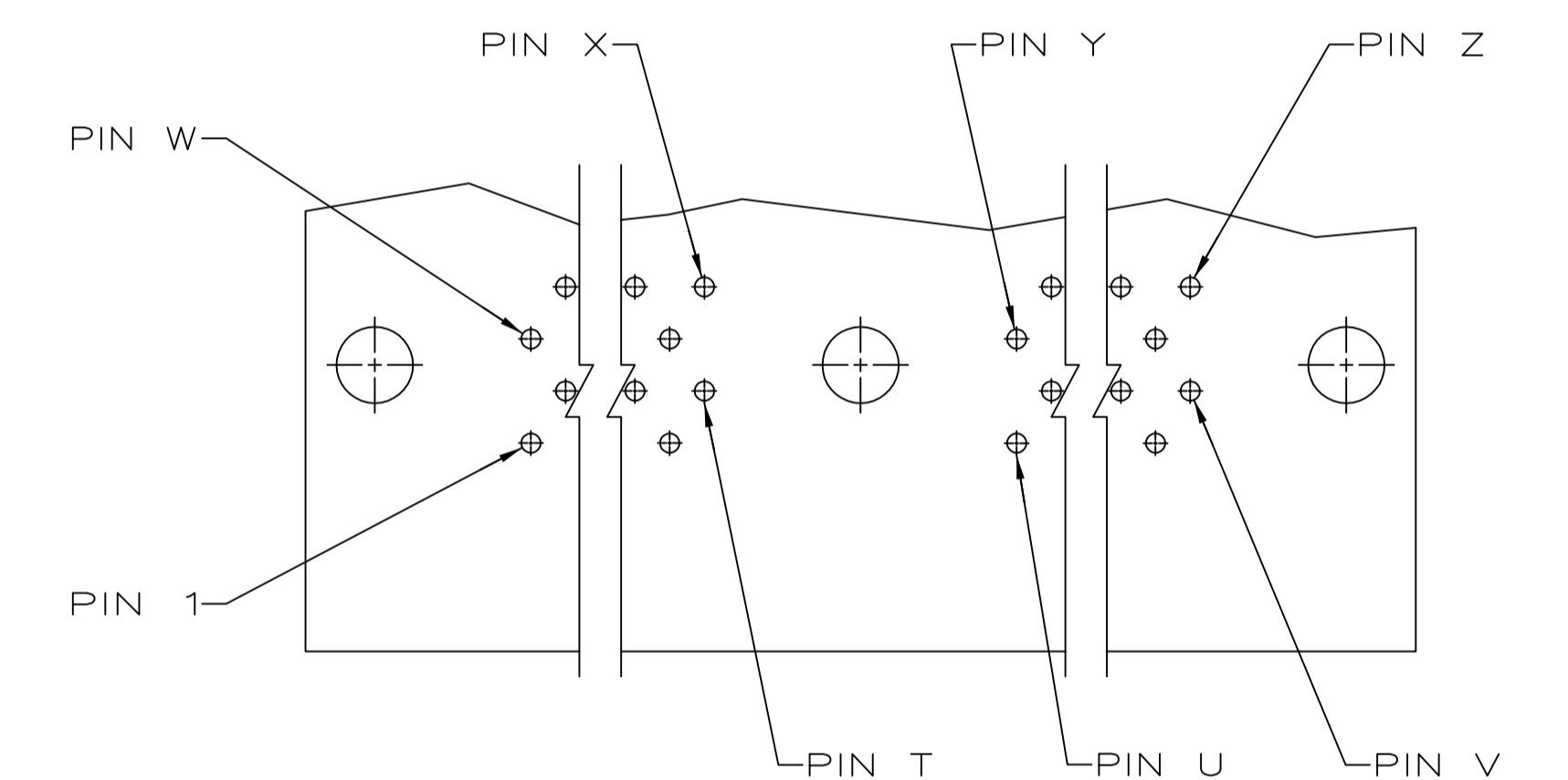
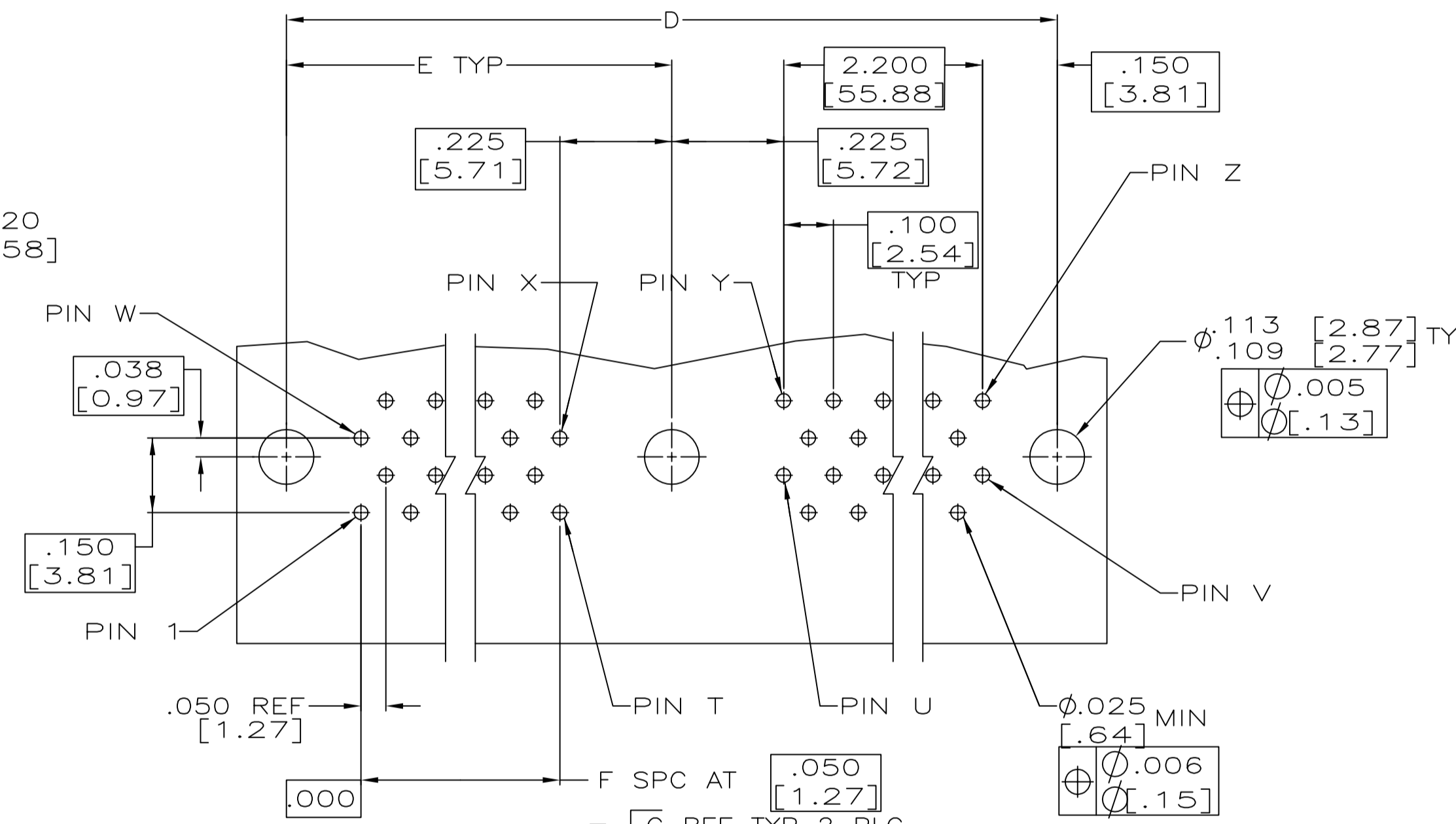
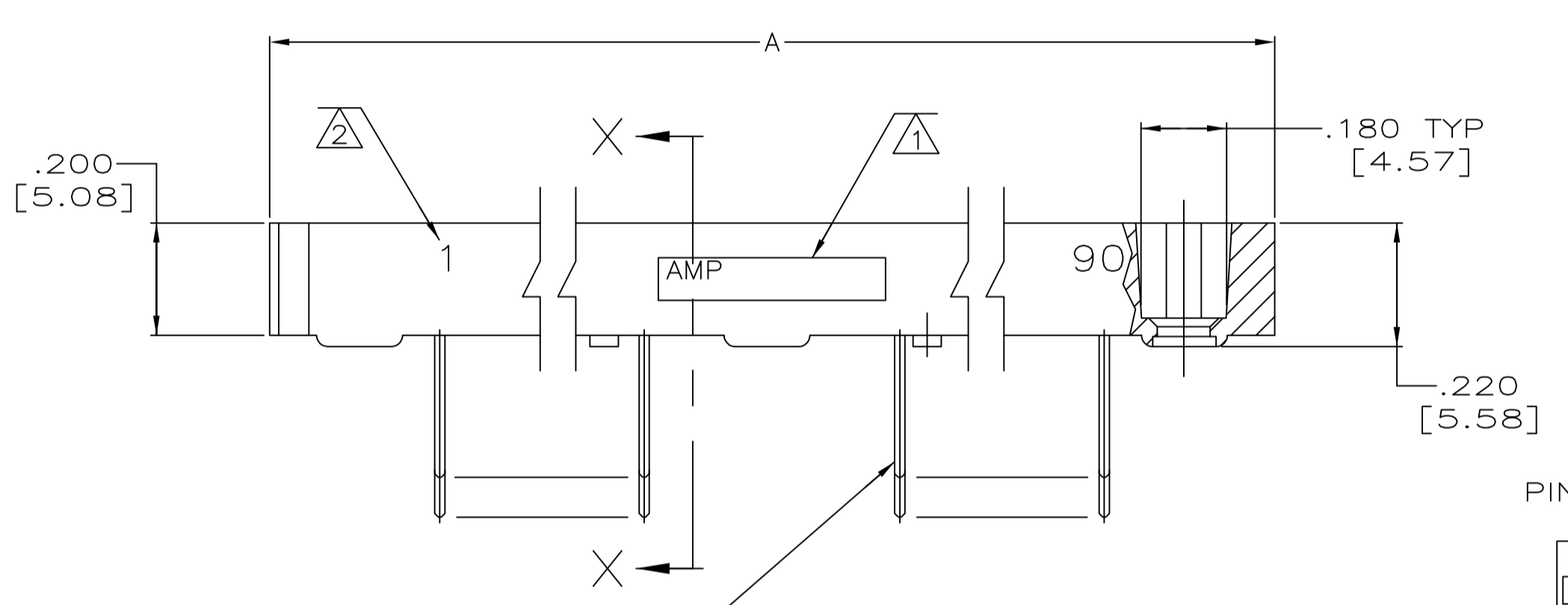

RECOMMENDED PRINTED CIRCUIT BOARD LAYOUT (CONNECTOR SIDE) FOOT PRINT STYLE II (SEE TABLE)

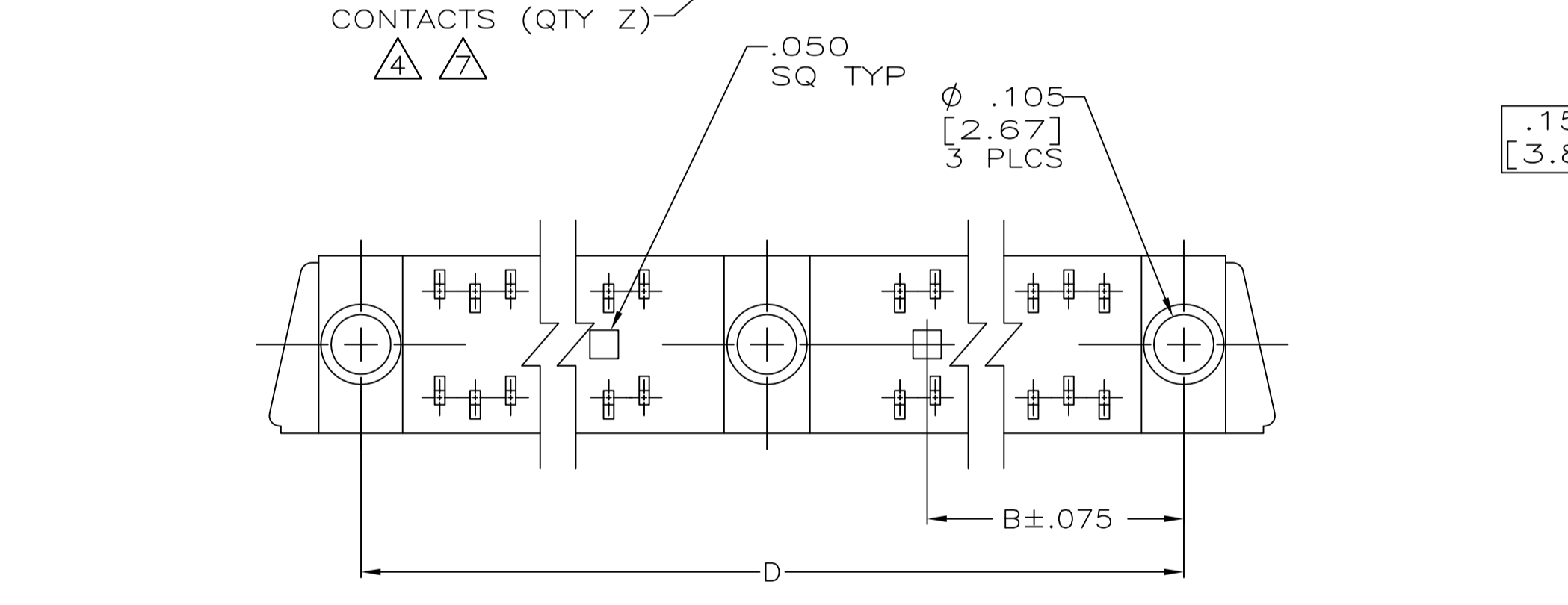

RECOMMENDED PRINTED CIRCUIT BOARD LAYOUT (CONNECTOR SIDE) FOOT PRINT STYLE I (SEE TABLE)

OBS	REMARKS	FOOT PRINT STYLE	Z	Y	X	W	V	U	T	CONTACT IDENT NUMBERS	K ± .015 [±0.38]	J ± .015 [±0.38]	H	G	F	E	D	C	B	A	NUMBER OF CONTACTS	PART NUMBER
1		I I	160	121	120	81	80	41	40	1 & 80	.190 [4.83]	.140 [3.56]	1.800 [45.72]	1.950 [49.53]	39	2.325 [59.06]	4.650 [118.11]	4.200 [106.68]	1.162 [29.51]	4.950 [125.73]	160	534179-9
2		I I	200	151	150	101	100	51	50	1 & 100	.300 [7.62]	.230 [5.84]	2.300 [58.42]	2.450 [62.23]	49	2.825 [71.76]	5.650 [143.51]	5.200 [132.08]	1.413 [35.89]	5.950 [151.13]	200	534179-8
3		I I	192	145	144	97	96	49	48	1 & 96	.300 [7.62]	.230 [5.84]	2.200 [55.88]	2.350 [59.69]	47	2.725 [69.22]	5.450 [138.43]	5.000 [127.00]	1.362 [34.59]	5.750 [146.05]	192	534179-7
4		I	180	136	135	91	90	46	45	1 & 90	.300 [7.62]	.230 [5.84]	2.050 [52.07]	2.200 [55.88]	44	2.575 [65.41]	5.150 [130.81]	4.700 [119.38]	1.287 [32.69]	5.450 [138.43]	180	534179-6
5		I	172	130	129	87	86	44	43	1 & 86	.300 [7.62]	.230 [5.84]	1.950 [49.53]	2.100 [53.34]	42	2.475 [62.87]	4.950 [125.73]	4.500 [114.30]	1.237 [31.42]	5.250 [133.35]	172	534179-5
6		I I	160	121	120	81	80	41	40	1 & 80	.300 [7.62]	.230 [5.84]	1.800 [45.72]	1.950 [49.53]	39	2.325 [59.06]	4.650 [118.11]	4.200 [106.68]	1.162 [29.51]	4.950 [125.73]	160	534179-4
7		I I	152	115	114	77	76	39	38	1 & 76	.300 [7.62]	.230 [5.84]	1.700 [43.18]	1.850 [46.99]	37	2.225 [56.52]	4.450 [113.03]	4.000 [101.60]	1.062 [26.97]	4.750 [120.65]	152	534179-3
8		I	140	106	105	71	70	36	35	1 & 70	.300 [7.62]	.230 [5.84]	1.550 [39.37]	1.700 [43.18]	34	2.075 [52.71]	4.150 [105.41]	3.700 [93.98]	1.037 [26.34]	4.450 [113.03]	140	534179-2
9		I	132	100	99	67	66	34	33	1 & 66	.300 [7.62]	.230 [5.84]	1.450 [36.83]	1.600 [40.64]	32	1.975 [50.17]	3.950 [100.33]	3.500 [88.90]	.987 [25.07]	4.250 [107.95]	132	534179-1

THIS DRAWING IS A CONTROLLED DOCUMENT. OWN: T. ALEXANDER 9-16-94. DW: D. GUTTER 9-20-94. APVD: D. GUTTER 9-20-94. NAME: RECEPTACLE ASSEMBLY, EXTENDED MINI-BOX WITH LOW FORCE CONTACTS, SPECIAL. PRODUCT SPEC: APPLICATION SPEC. SIZE: A1. CAGE CODE: 00779. DRAWING NO: 534179. RESTRICTED TO: CUSTOMER DRAWING. SCALE: 4:1. SHEET: 1 OF 1. REV: R.