

P	LTR	DESCRIPTION	DATE	DWN	APVD
C		REV PER ECO 19-019314	2-27-20	CT	PD

1. MATERIAL:
BODY: ALUMINUM PER ASTM B317
INSERT: BRASS PER ASTM B36
2. FINISH:
BODY: .000600 MIN MATTE TIN PER ASTM B545
OVER .000060 MIN NICKEL PER ASTM B733.
INSERT: .000150 MIN MATTE NICKEL PER QQ-N-290
3. PTFE DRY LUBRICANT 360 DEGREE ON OUTER DIAMETER OF CRIMP BARREL IN ZONE SHOWN.
4. WIRE INSULATION RANGE: .590-.683.
5. SEE TE CONNECTIVITY APPLICATION SPEC. 114-32098 FOR APPLICATION REQUIREMENTS.
6. SEE TE CONNECTIVITY INSTRUCTION SHEET 408-32087 FOR TOOLING AND CRIMP INSTRUCTIONS, FIGURE 3 FOR WIRE STRIPPING DETAIL.

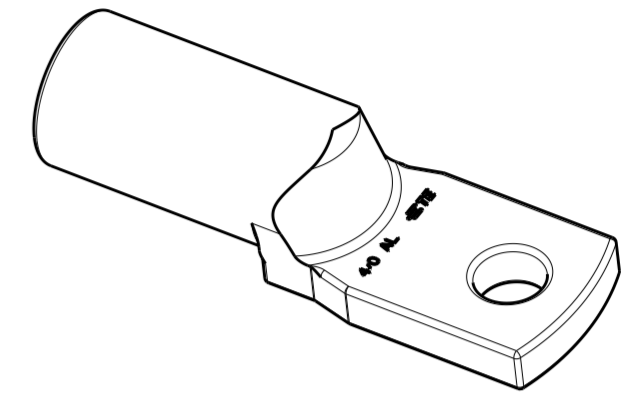

SCALE 1:1

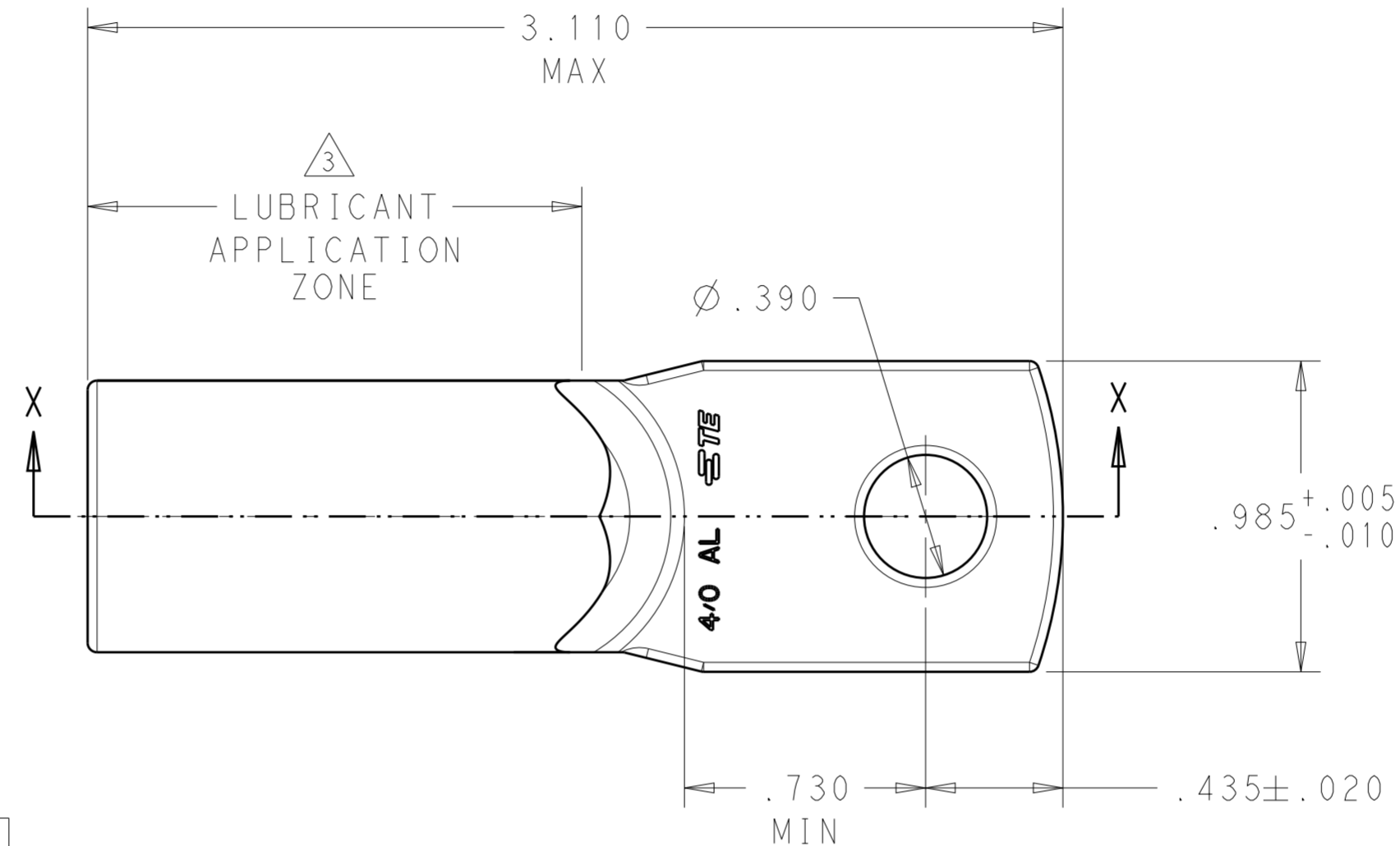
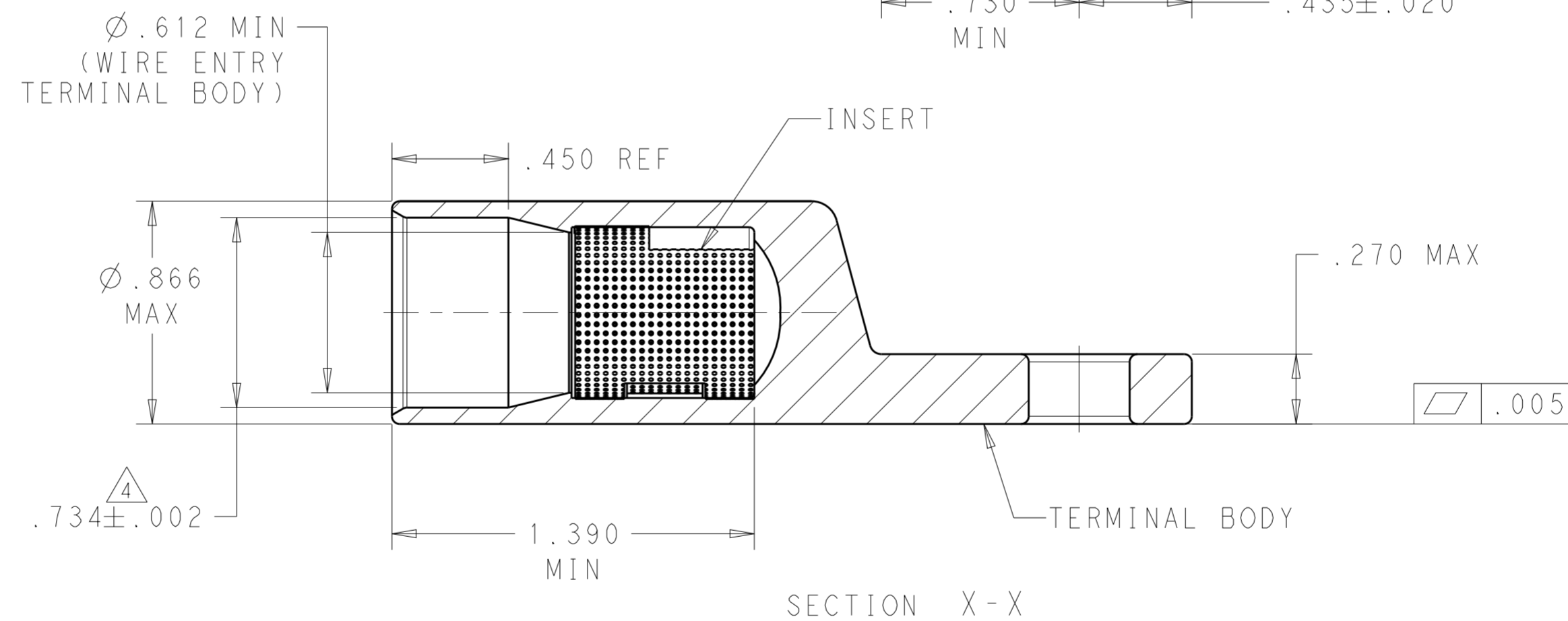

2102575-1
PART
NUMBER

THIS DRAWING IS A CONTROLLED DOCUMENT.		DWN D. FABIAN 23AUG2012	TE Connectivity	
DIMENSIONS: INCHES		CHK DEBOCK, KIM 28NOV2012		
TOLERANCES UNLESS OTHERWISE SPECIFIED:		APVD DEBOCK, KIM 28NOV2012	NAME ASSEMBLY, ALUMINUM TERMINAL, STRAIGHT, SINGLE HOLE, 4/0	
0 PLC ±-		PRODUCT SPEC	SIZE	
1 PLC ±.1		APPLICATION SPEC	CAGE CODE	
2 PLC ±.01		WEIGHT	DRAWING NO	
3 PLC ±.005			RESTRICTED TO	
4 PLC ±.0005			A200779	
ANGLES ±1°			C-2102575	
FINISH			SCALE 2:1	
MATERIAL SEE CALL-OUT material_2			SHEET 1 OF 1	
FINISH SEE CALL-OUT finish_spec_2		CUSTOMER DRAWING	REV C	