

THIS DRAWING IS UNPUBLISHED. RELEASED FOR PUBLICATION  
 © COPYRIGHT - By - ALL RIGHTS RESERVED.

LOC		DIST		REVISIONS			
P	LTR	DESCRIPTION	DATE	DWN	APVD		
E1		ECR-13-017177	05NOV13	PKS	RRP		

- 1 CONTINUOUS STRIP ON REELS WITH TERMINALS LOCATED ON  $5.59 \pm 0.08$   $[\pm 0.003]$  CENTERS.
- 2 SLOT ACCEPTS 0.32-0.50mm [#28-#24] AWG COPPER MAGNET WIRE. 2 WIRES OF THE SAME SIZE PER SLOT.
- 3 BARREL TO ACCEPT 0.2-0.6mm<sup>2</sup> [#24-#20] AWG LEAD WIRE.

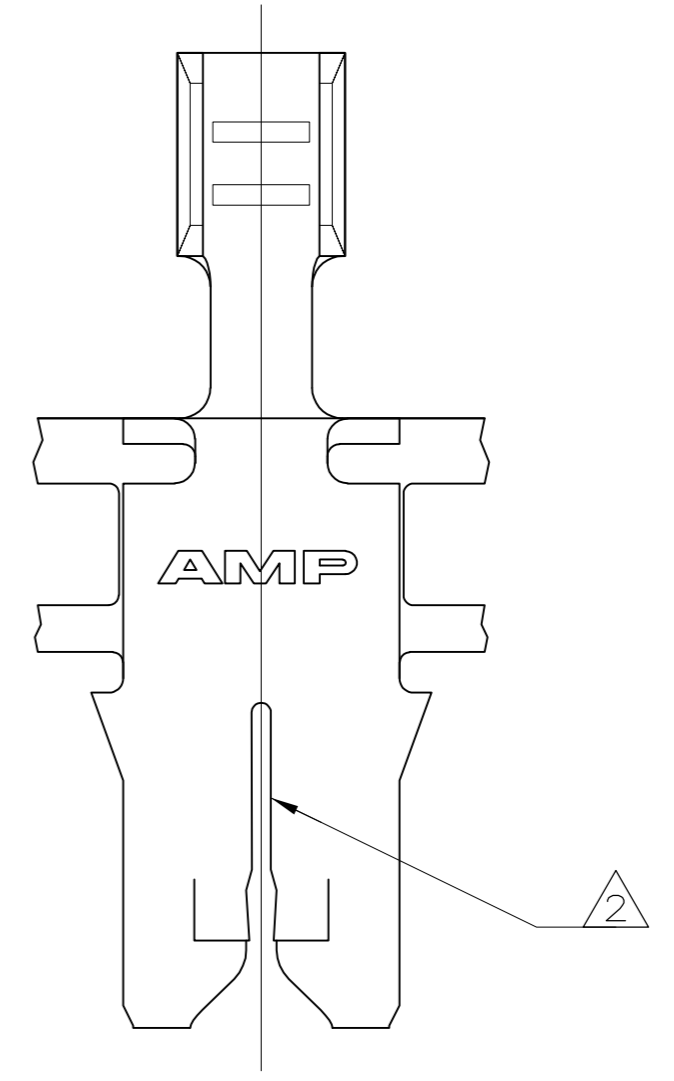
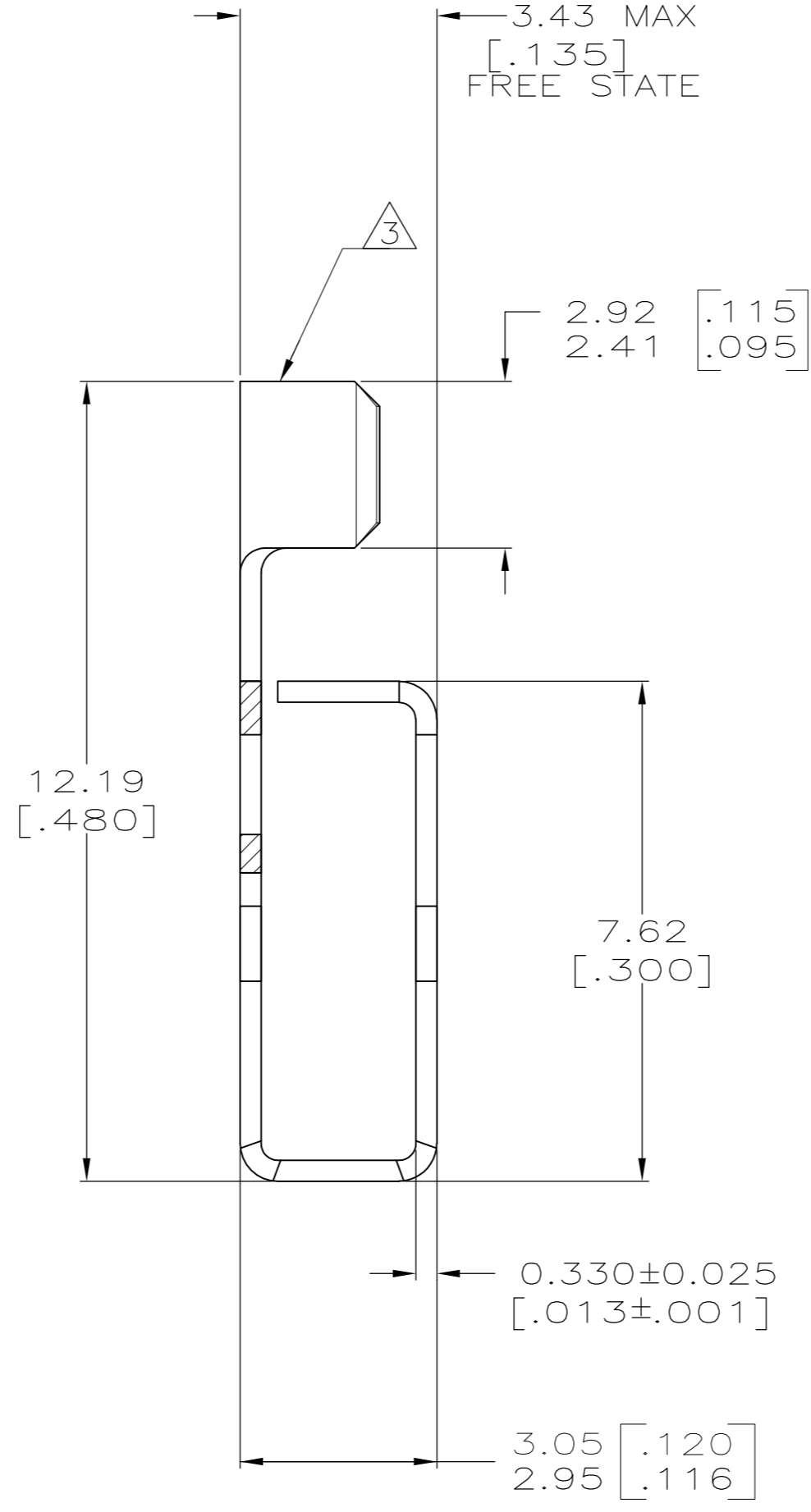
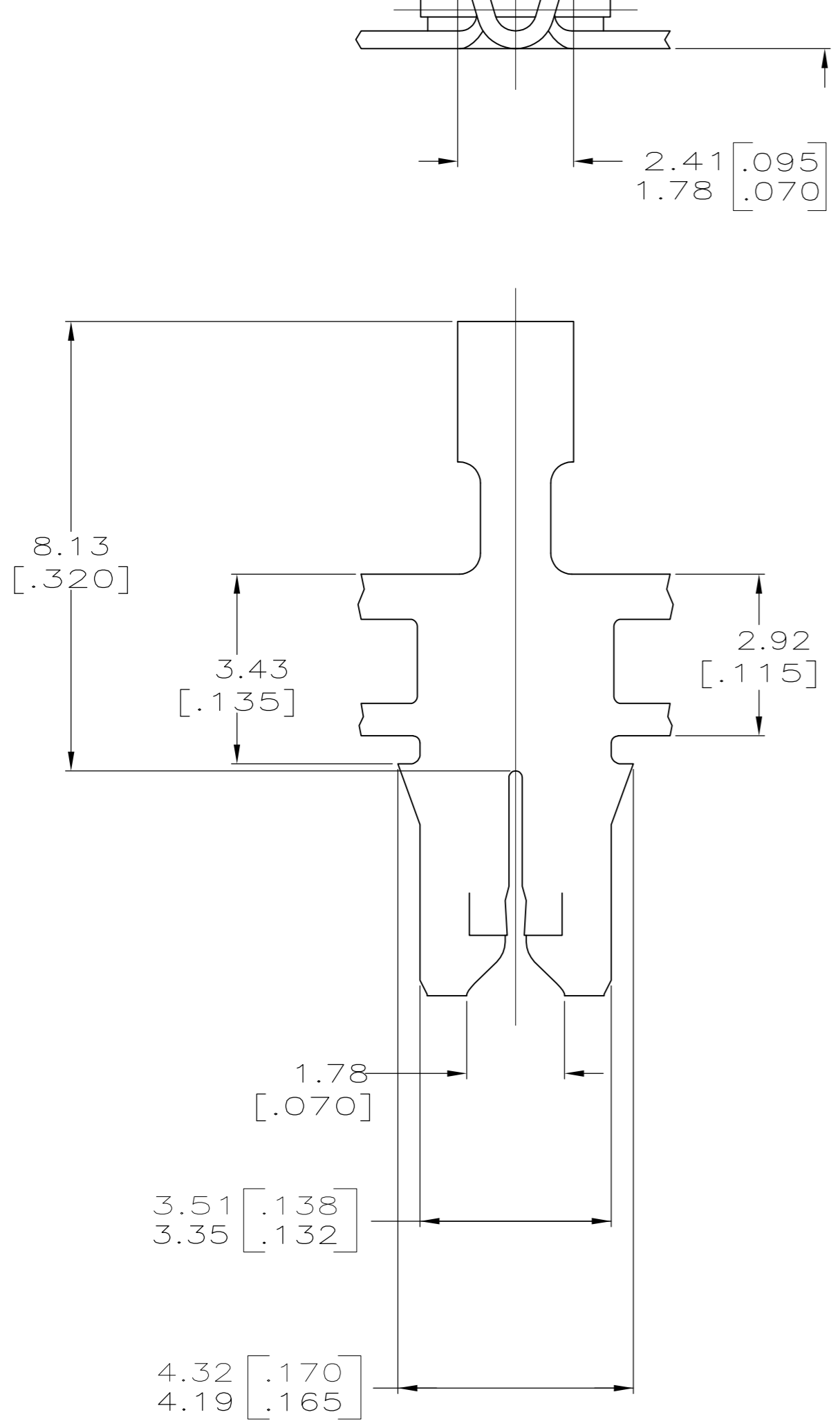
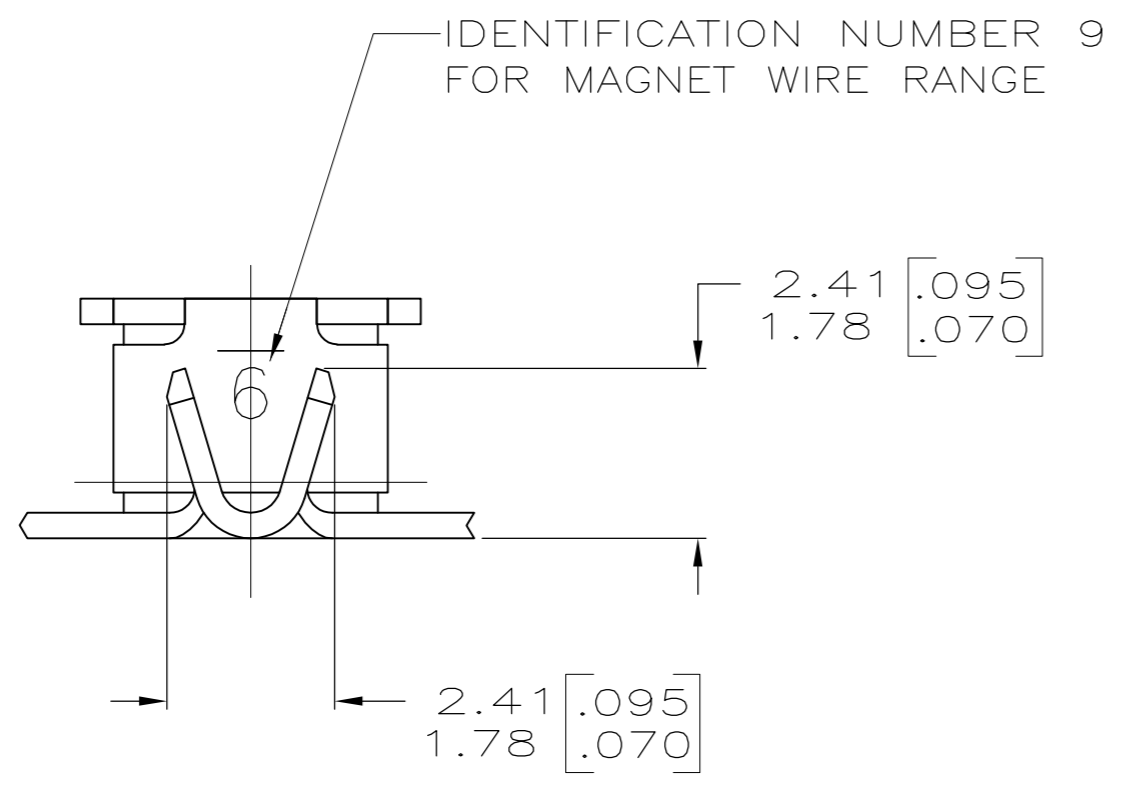

THIS DRAWING IS A CONTROLLED DOCUMENT.		DWN K.L.STONEROD 09DEC99	<b>TE</b> TE Connectivity	
DIMENSIONS: INCHES		CHK M.S.FEHER 09DEC99		
TOLERANCES UNLESS OTHERWISE SPECIFIED:		APVD K.A.RANDOLPH 09DEC99	NAME TERMINAL, F-CRIMP 300 SERIES MAG-MATE™	
0 PLC ± -		PRODUCT SPEC 108-2012	SIZE A2	CAGE CODE 00779
1 PLC ± -		APPLICATION SPEC 114-2046	DRAWING NO C=63641	RESTRICTED TO -
2 PLC ± 0.25 [.010]		MATERIAL BRASS	SCALE 10:1	SHEET 1 OF 1
3 PLC ± -		FINISH TIN PLATE	REV E1	
4 PLC ± -		CUSTOMER DRAWING		
ANGLES ± -				