

CCM01 MK I



CCM01 MK I connectors have fixed contacts and a blade card detection switch (not sealed).

These connectors are intended for applications where the card usage is relatively low and the environment is benign.

Features

- Available with 8 or 16 through hole contacts.
- A normally closed blade switch detects when the card is fully inserted.
- Snap in boardlocks hold the connector in place prior to soldering.

Construction	
Contacts	Copper alloy
Plating	Contact area : Gold over nickel Terminals : Tin lead (2 μ min)
Moldings	Thermoplastic UL 94V-0 rated
Card detection switch	Copper alloy

Mechanical data	
Number of Contacts	8 or 16
Mechanical life	10,000 cycles min
Card insertion force	10 N max
Card extraction force	1 N min / 10N max
Contact force	0.20 N min / 0.60 N max
Vibration	Frequency 10 to 500 Hz. Acceleration 50m/s ² Duration 6 hours - amplitude 0.35 mm (0.014) Max electrical discontinuity 1 μ s
Shock	Peak value 500 m/s ² - Duration 11 ms 3 shocks in each direction of each axis Max electrical discontinuity 1 μ s

Electrical data	
Insulation resistance	1,000 M Ω min
Contact resistance max	100 m Ω max
Switching current	10 μ A min / 1 A max
Dielectric strength	750 Vrms min
Card detection switch	Normally closed
Rc card detection switch	100 m Ω max
Dielectric strength card detection switch	250 Vrms min
Switch current rating	1 mA min / 10 mA max
Maximum switch power	0.2 VA

Environmental data	
Operating temperature	-40°C to +85°C
Soldering temperature	Wave : 260°C / 5 sec
Damp heat	IEC 512 test number 11c (10 days)
Salt mist	IEC 512 test number 11f (96 hours)
Card detection switch	Not sealed blade switch

Ordering code		
Part Number	N° of Contacts	Packaging Multiple
CCM01-1NF	8	200
CCM01-2NF	16	200

Packaging
20 per tray, 10 trays per box.
Order multiple 200

CCM01 MK I

Dimensional Drawings

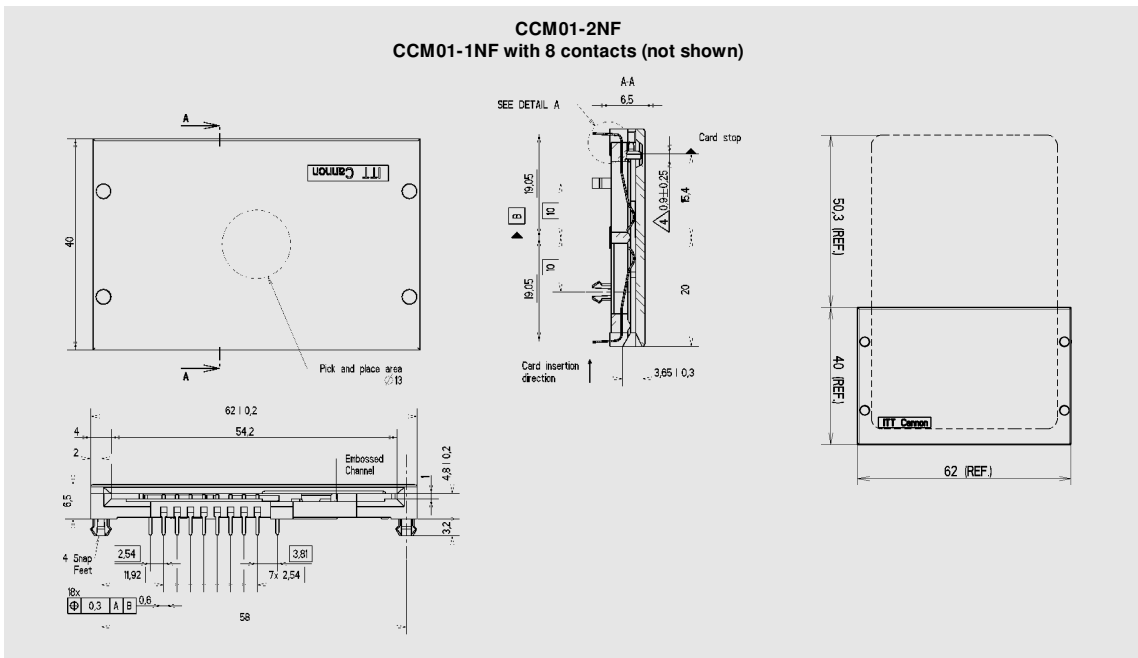

PCB Layout

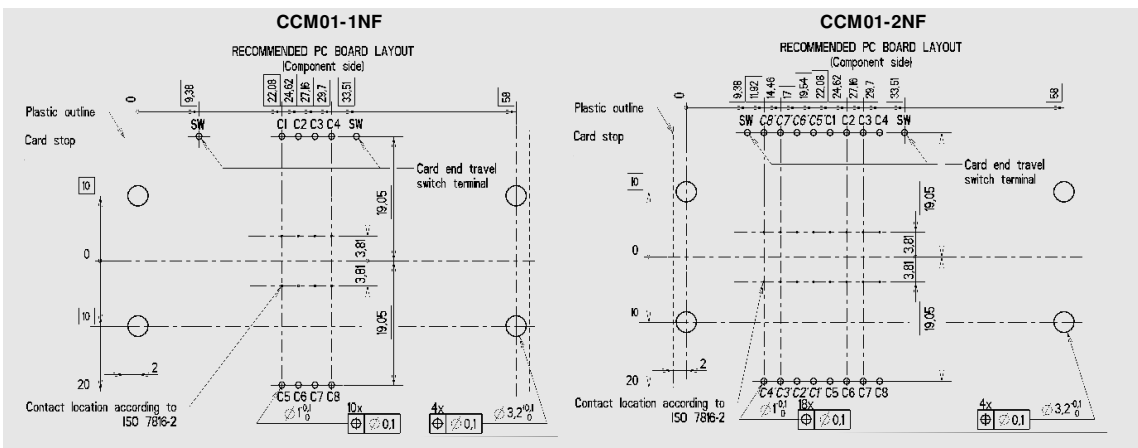

CCM01 MK II



The CCM01 MK II connectors with fixed contacts have been developed for applications where a landing contact mechanism is not required but performance and reliability are still key considerations.

Features

- Available with 8 or 16 contacts which are designed to give a consistently reliable normal force over the life of the connector.
- For added reliability, the card detection switch (which is normally open) is sealed against dust and debris.
- Available with through-hole or surface mount contact termination and its lightweight design means that the connector can be automatically pick-and-placed.
- The moldings are made from high temperature thermoplastics suited for infrared and convection soldering processes.
- Plastic springs in the cover give a positive feel as the card is fully inserted. In case of special version with low card insertions and withdrawal, then the CCM connector is supplied without this spring effect.
- The reduced size of the contact base saves PCB space, makes the connector more stable during soldering and creates an air gap between the contacts and card entry slot, so reducing the risk of an electrostatic transfer to the PCB.
- By using an inlay finish in the contact area, the life of the precious metal is extended by more than 10 times that of standard gold plating.
- A chamfered opening to the card entry slot improves the card guidance into the connector.
- The contact area is spooned to reduce the risk of accidental (or deliberate) damage and to optimize the electrical connection with the card.
- Robustly formed printed circuit tails allow a coplanarity of ± 0.05 mm to be maintained.

Construction	
Contacts	Copper alloy
Plating	Contact area : Gold alloy inlay Terminals : Tin lead (2 μ min)
Moldings	High temp. thermoplastic UL 94V-0 rated
Card detection switch	Stainless steel and copper alloy

Mechanical data	
Number of Contacts	8 or 16
Mechanical life	100,000 cycles min
Durability of inlay	5,000 cycles min (see note 1)
Card insertion force	10 N max
Card extraction force	1 N min / 10N max (4N max for CCM01-2253, 2254, 2255, 2256)
Contact force	0.25 N min / 0.50 N max
Card detection switch actuation force	0.8 N max for actuation (end travel switch actuates when card is 0.9 mm from card stop) 1.8 N max for complete depression
Vibration	Frequency 10 to 500 Hz. Acceleration 50m/s ² Duration 6 hours - amplitude 0.35 mm Max electrical discontinuity 1 μ s
Shock	Peak value 500 m/s ² - Duration 11 ms 3 shocks in each direction of each axis Max electrical discontinuity 1 μ s

Electrical data	
Insulation resistance	1,000 M Ω min
Contact resistance max	100 m Ω max
Switching current	10 μ A min / 1 A max
Dielectric strength	750 Vrms min
Card detection switch	Normally open
Rc card detection switch	100 m Ω max
Dielectric strength card detection switch	250 Vrms min
Switch current rating	1 mA min / 10 mA max
Maximum switch power	0.2 VA

Environmental data	
Operating temperature	-40°C to +85°C
Soldering temperature	Temperature/time profile acc. to CECC00802 para. 6.1, Fig. 3 with peak temperature 250°C
Damp heat	IEC 512 test number 11c (10 days)
Salt mist	IEC 512 test number 11f (96 hours)
Card detection switch	Sealed against dust

Part Number	N° of Contacts	Termination Tail Design	Retention Force	Packaging Multiple
CCM01-2065	8	SMT w/board lock	<10N	300
CCM01-2067	16	SMT w/board lock	<10N	300
CCM01-2251	8	SMT	<10N	300
CCM01-2252	16	SMT	<10N	300
CCM01-2253	8	SMT	<4N	300
CCM01-2254	16	SMT	<4N	300
CCM01-2255	8	Through hole	<4N	300
CCM01-2256	16	Through hole	<4N	300

Packaging

30 per tray, 10 trays per box.
Order multiple 300

Note 1: Inlay (precious metal) rating is based on a very abrasive card being used and is intended to represent worst case.

CCM01 MK II

Dimensional Drawings

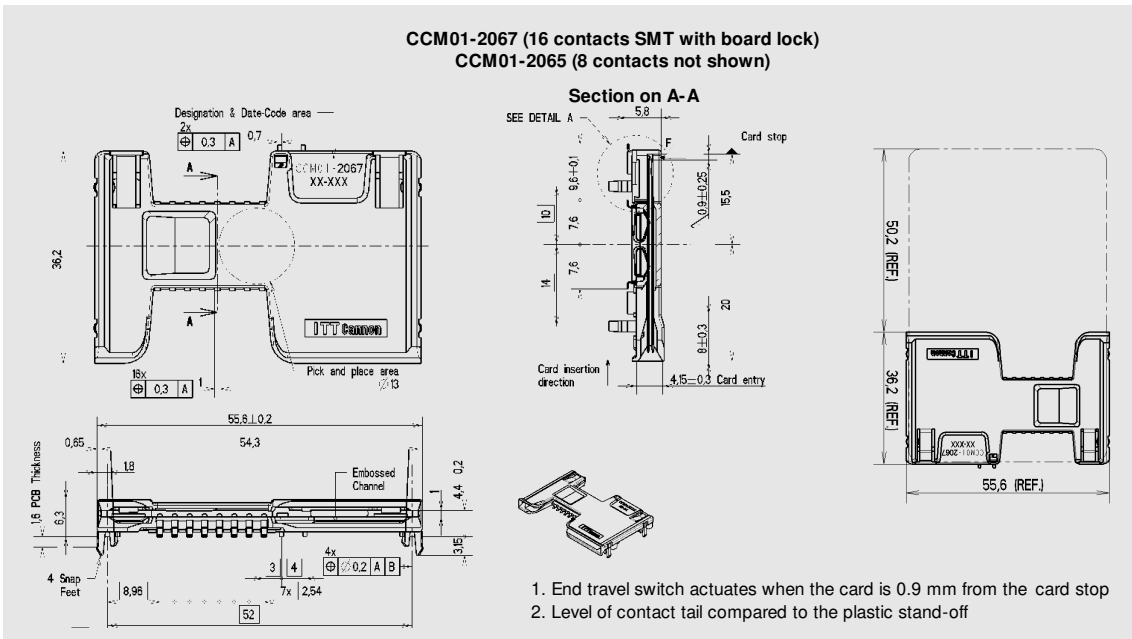

PCB Layout

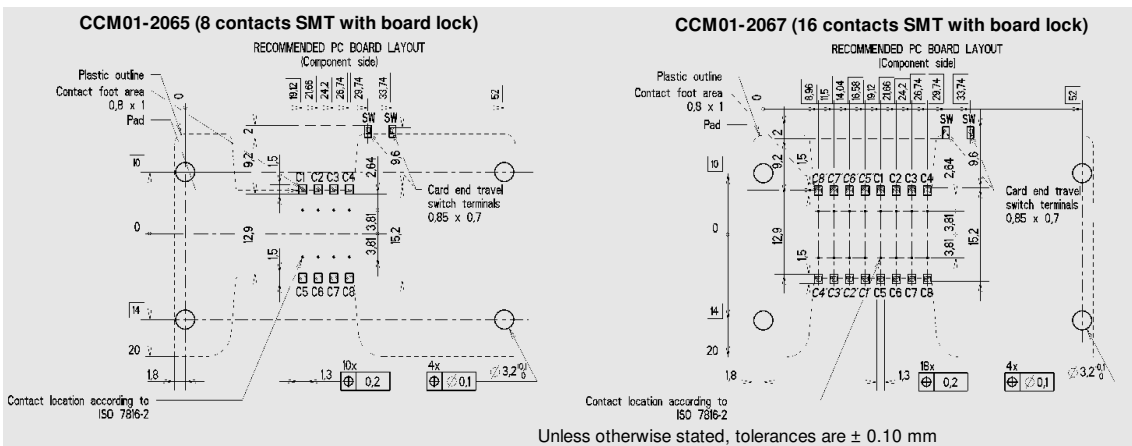

CCM01 MK II

Dimensional Drawings

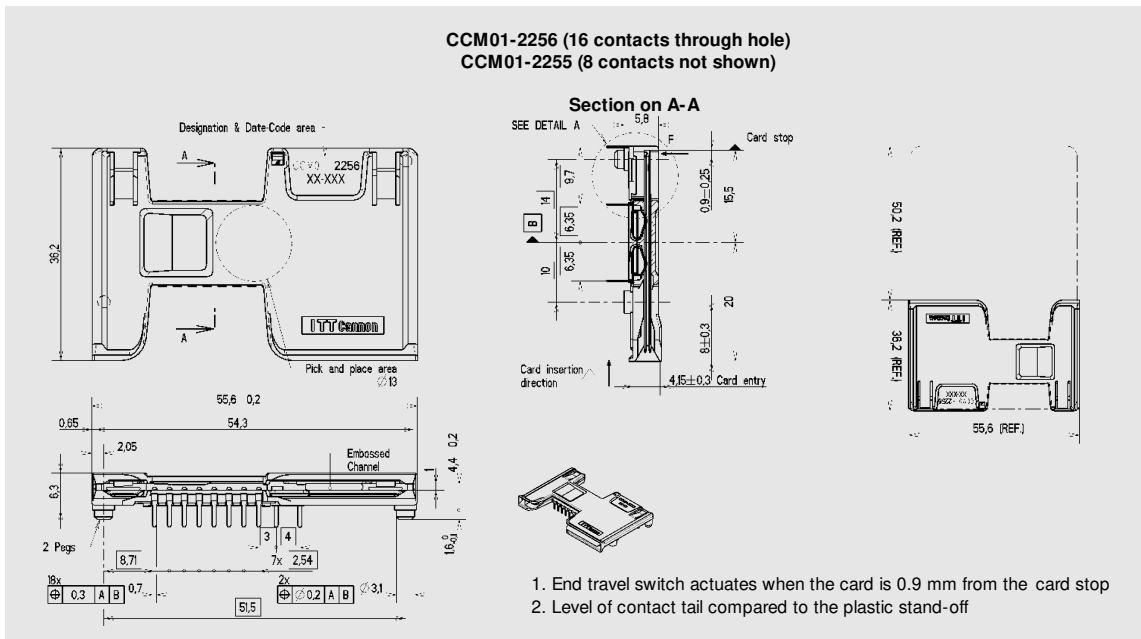

PCB Layout

