

THIS DRAWING IS UNPUBLISHED. RELEASED FOR PUBLICATION  
 © COPYRIGHT 20 BY - ALL RIGHTS RESERVED.

| LOC |     | DIST                      |           | REVISIONS |      |  |  |
|-----|-----|---------------------------|-----------|-----------|------|--|--|
| P   | LTR | DESCRIPTION               | DATE      | DWN       | APVD |  |  |
| B2  |     | REVISED PER ECR-17-007671 | 05JUN2017 | O.C       | D.Z  |  |  |
|     |     |                           |           |           |      |  |  |

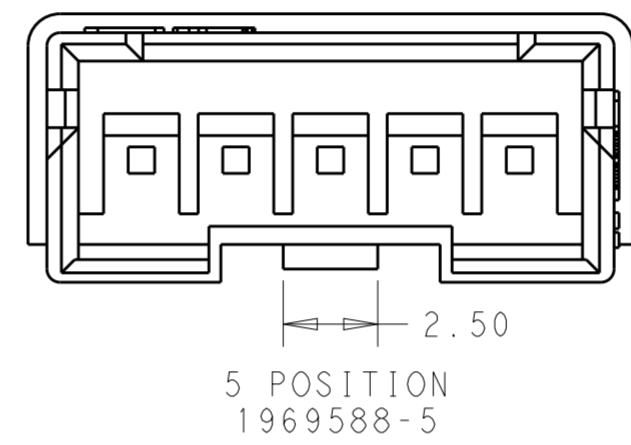

1. MATERIAL: NYLON UL94V-0, COLOR: NATURAL
2. ACCEPTS TE PIN CONTACTS P/N'S 2238007-()
3. HOUSING ACCEPTS OPTIONAL TPA P/N'S 1969443-()
4. MATES WITH TE PLUG HOUSINGS P/N'S 1969442-()

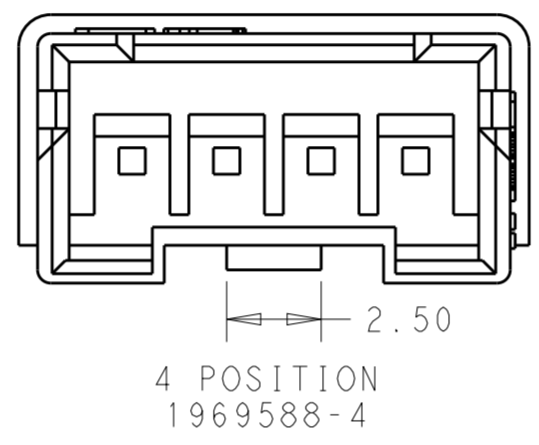
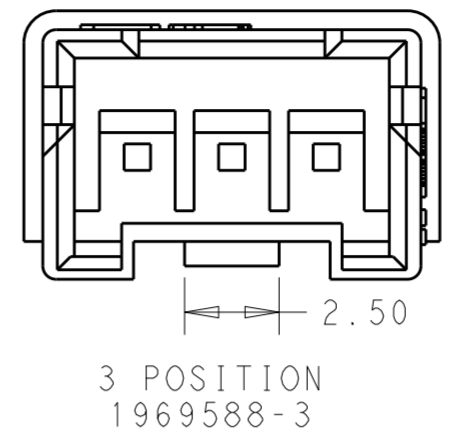
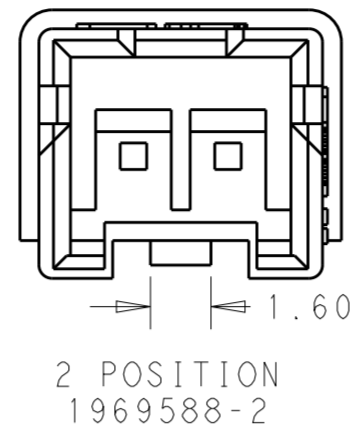
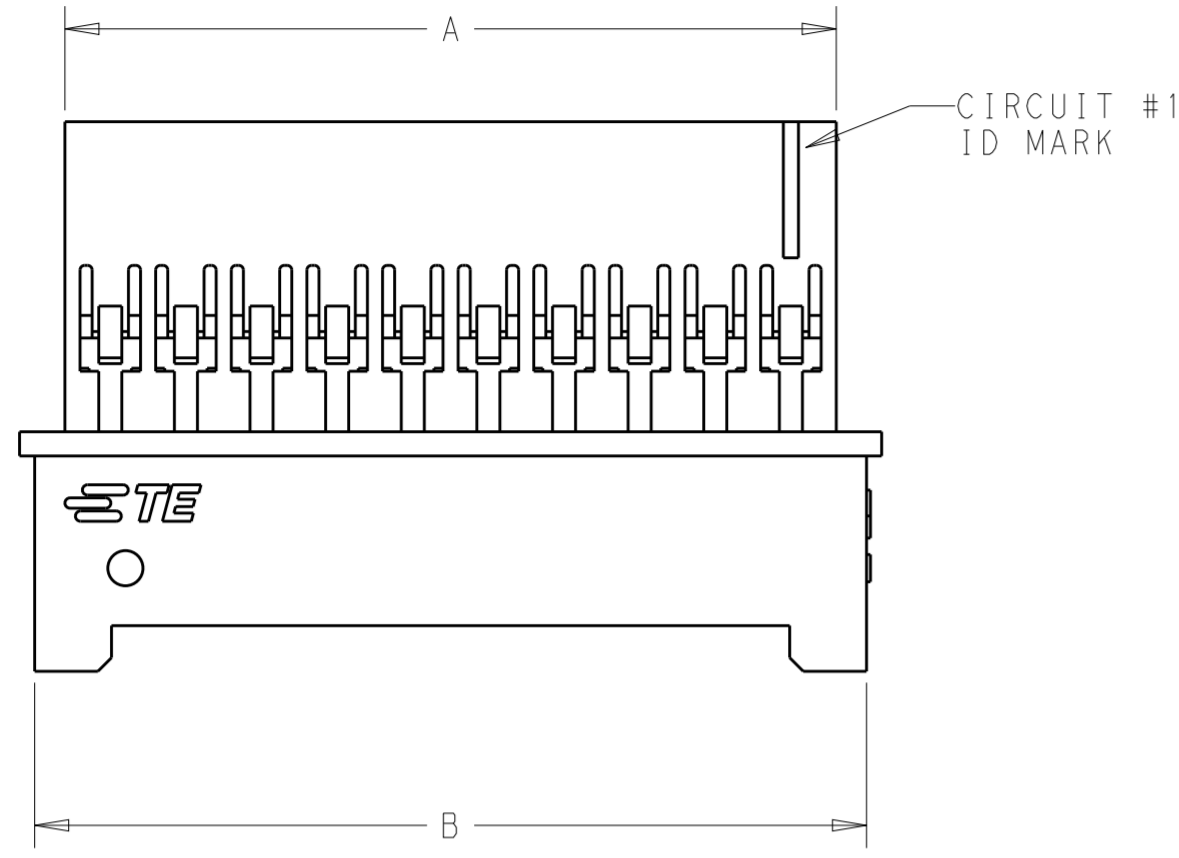
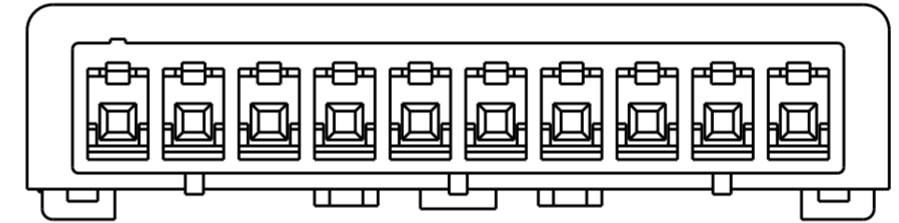
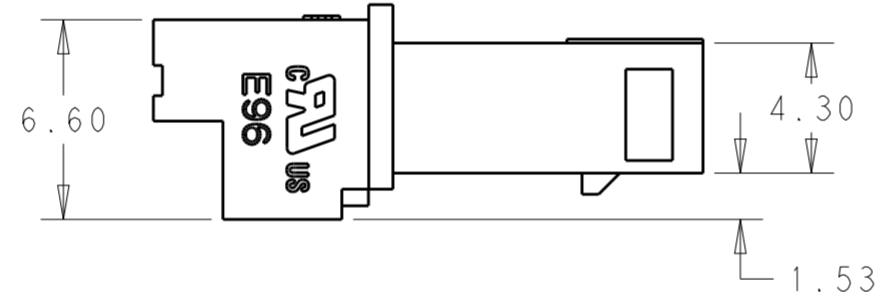
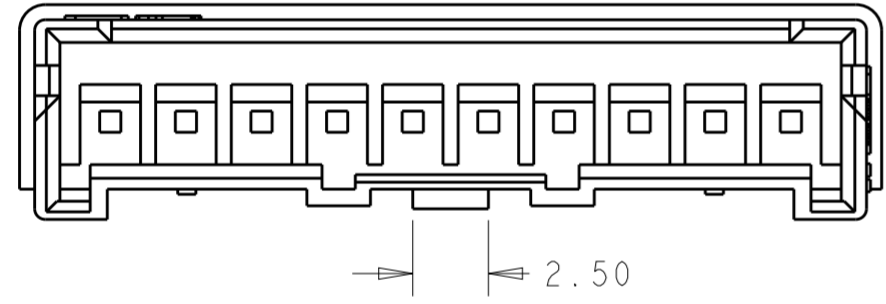

6 - 15 POSITION  
1969588-6 TO 1-1969588-5

| POS | DIM. B | DIM. A | PART NO.    |
|-----|--------|--------|-------------|
| 15  | 40.00  | 38.00  | 1-1969588-5 |
| 14  | 37.50  | 35.50  | 1-1969588-4 |
| 13  | 35.00  | 33.00  | 1-1969588-3 |
| 12  | 32.50  | 30.50  | 1-1969588-2 |
| 11  | 30.00  | 28.00  | 1-1969588-1 |
| 10  | 27.50  | 25.50  | 1-1969588-0 |
| 9   | 25.00  | 23.00  | 1969588-9   |
| 8   | 22.50  | 20.50  | 1969588-8   |
| 7   | 20.00  | 18.00  | 1969588-7   |
| 6   | 17.50  | 15.50  | 1969588-6   |
| 5   | 15.00  | 13.00  | 1969588-5   |
| 4   | 12.50  | 10.50  | 1969588-4   |
| 3   | 10.00  | 8.00   | 1969588-3   |
| 2   | 7.50   | 5.50   | 1969588-2   |

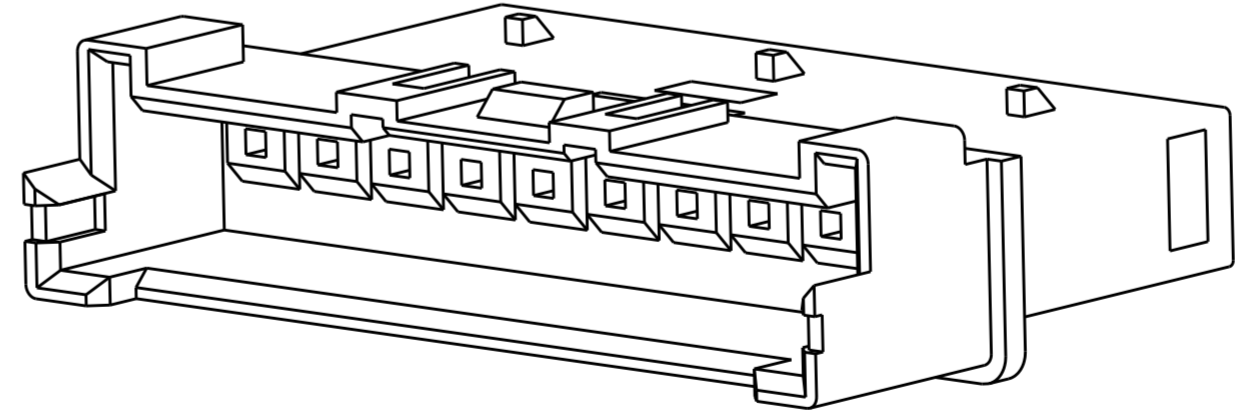
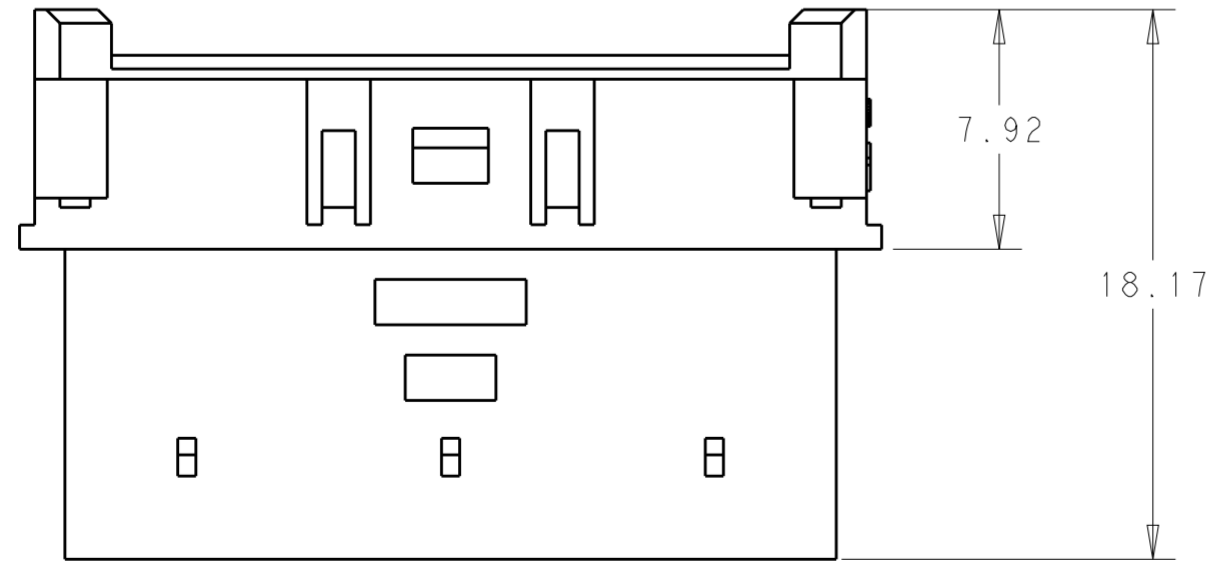

SCALE 5:1

|  |  |                  |           |   |                    |
|--|--|------------------|-----------|---|--------------------|
| THIS DRAWING IS A CONTROLLED DOCUMENT. |  | DWN<br>A. NOEL   | 030C2012  | TE Connectivity<br>NAME<br>ECONOMY POWER 2.5, HOUSING<br>WIRE TO WIRE |                    |
| DIMENSIONS:<br>mm                      |  | CHK<br>-         | APVD<br>- |   |                    |
| TOLERANCES UNLESS OTHERWISE SPECIFIED: |  | APVD<br>-        |           | APPLICATION SPEC<br>114-13315   | RESTRICTED TO<br>- |
| MATERIAL                               |  | WEIGHT<br>-      |           | SIZE<br>A2  | CAGE CODE<br>00779 |
| SEE NOTES                              |  | SEE NOTES        |           | DRAWING NO<br>C-1969588   | SCALE<br>3:1       |
|  |  | CUSTOMER DRAWING |           | SHEET<br>1  | OF<br>1            |
|  |  |                  |           | REV<br>B2   |                    |