

THIS DRAWING IS UNPUBLISHED. RELEASED FOR PUBLICATION
 © COPYRIGHT - By - ALL RIGHTS RESERVED.

LOC		DIST		REVISIONS			
P	LTR	DESCRIPTION		DATE	DWN	APVD	
E	B	BA	NEW DRAWING	13FEB2013	KR	TN	

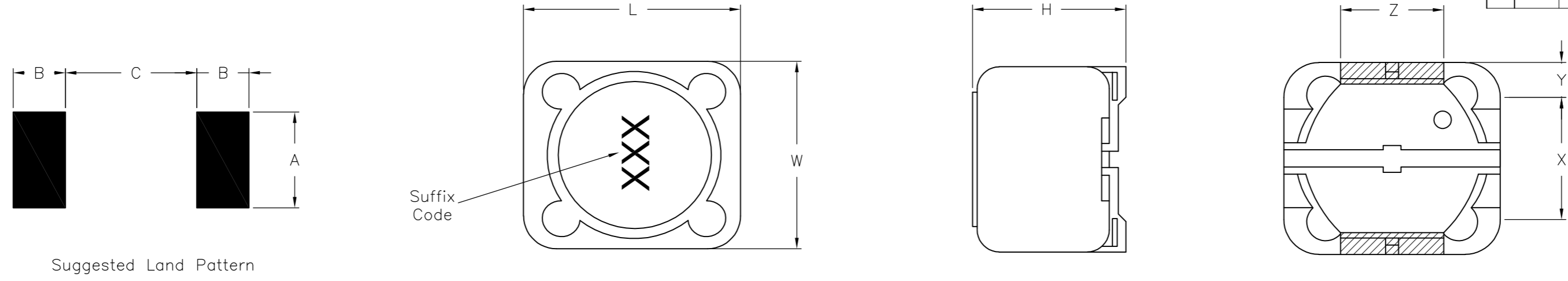

Series Number	Maximum Dimensions				Reference Dimensions					
	Units	L	W	H	X	Y	Z	A	B	C
MGDQ5	inches	0.504"	0.504"	0.236"	0.315"	0.087"	0.197"	0.202"	0.084"	0.307"
	[mm]	[12.80]	[12.80]	[6.00]	[8.00]	[2.20]	[5.00]	[5.13]	[2.13]	[7.80]

MGDQ5				
Lead Free Part Number	L μ H	DCR	Isat	Tolerance
		Ω	A	Suffix
MGDQ5-00001-P	1.5	0.003	16.00	M
MGDQ5-00002-P	2.4	0.009	13.50	M
MGDQ5-00003-P	3.3	0.007	12.70	M
MGDQ5-00004-P	4.7	0.018	10.00	M
MGDQ5-00005-P	10	0.025	4.00	M
MGDQ5-00006-P	12	0.027	3.50	M
MGDQ5-00007-P	15	0.030	3.30	M
MGDQ5-00008-P	18	0.034	3.00	M
MGDQ5-00009-P	22	0.036	2.80	M
MGDQ5-00010-P	27	0.051	2.30	M
MGDQ5-00011-P	33	0.057	2.10	M
MGDQ5-00012-P	39	0.068	2.00	M
MGDQ5-00013-P	47	0.075	1.80	M
MGDQ5-00014-P	56	0.110	1.70	M
MGDQ5-00015-P	68	0.120	1.50	M
MGDQ5-00016-P	82	0.140	1.40	M
MGDQ5-00017-P	100	0.160	1.30	M
MGDQ5-00018-P	120	0.170	1.10	M
MGDQ5-00019-P	150	0.230	1.00	M
MGDQ5-00020-P	180	0.290	0.90	M
MGDQ5-00021-P	220	0.400	0.80	M
MGDQ5-00022-P	270	0.460	0.75	M
MGDQ5-00023-P	330	0.510	0.68	M
MGDQ5-00024-P	390	0.690	0.65	M
MGDQ5-00025-P	470	0.770	0.58	M
MGDQ5-00026-P	560	0.860	0.54	M
MGDQ5-00027-P	680	1.200	0.48	M
MGDQ5-00028-P	820	1.340	0.43	M
MGDQ5-00029-P	1000	1.530	0.40	M

Features:

1. High energy storage and low resistance
2. Reliable surface mounting, flat top for pick and place.
3. Smaller real estate than other common inductors
4. Robust temperature deflection to prevent damage during solder reflow.
5. Tape and Reel mechanical specifications available upon request.
6. Operating Temperature -40°C to +85°C.
7. Highly resistive core for EMI suppression applications.

Notes:

1. Inductance measured at 100kHz and 250mVrms.
2. Isat is a maximum applied AC + DC current.
3. Isat current is applied to produce a typical 35% drop in nominal inductance.
4. Tolerance suffix of M = $\pm 20\%$.
5. DCR is a maximum at 20°C

Schematic Diagram

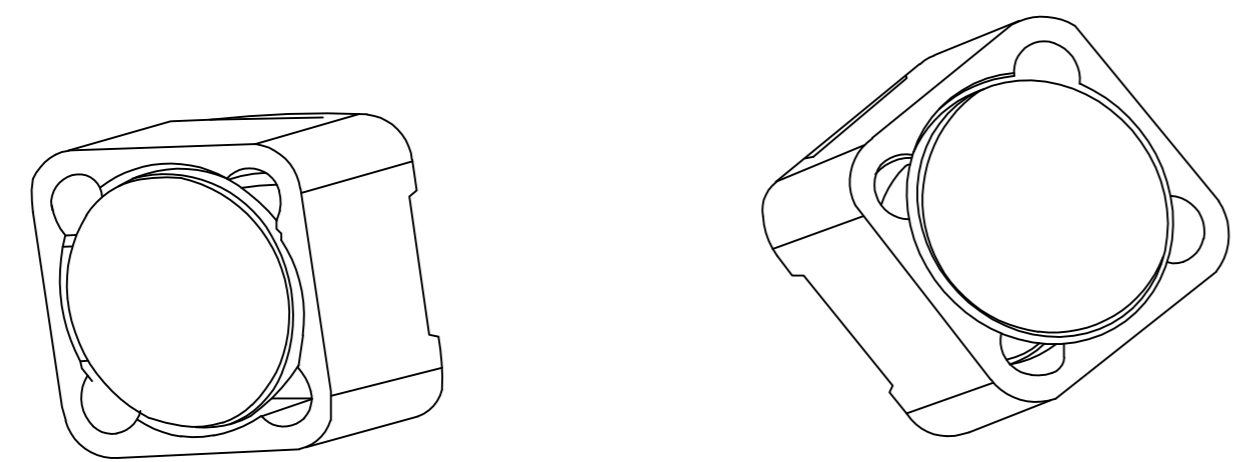
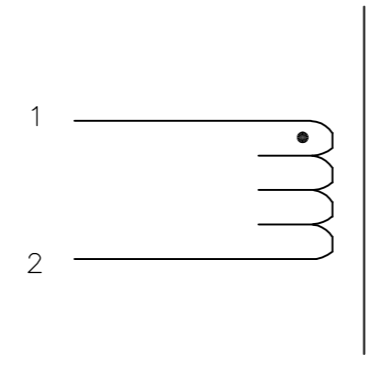

RoHS Compliant

260°C Maximum reflow temperature per J-ST-D020
 Terminal Plating is Gold Flash over Ni

LOW PROFILE, HIGH CURRENT POWER INDUCTORS

Specifications subject to change

THIS DRAWING IS A CONTROLLED DOCUMENT.		DWN RAGHAVENDRA K 13FEB2013	TE Connectivity	
DIMENSIONS: INCHES[MM]		CHK ALLAN P 13FEB2013		
TOLERANCES UNLESS OTHERWISE SPECIFIED:		APVD TONY N 13FEB2013	NAME MGDQ5 - LOW PROFILE HIGH CURRENT POWER INDUCTOR DATA SHEET	
0 PLC ± 0.5 1 PLC ± 0.2 2 PLC ± 0.1 3 PLC $\pm -$ 4 PLC $\pm -$ ANGLES ± 5		PRODUCT SPEC -	SIZE A2	CAGE CODE 00779
MATERIAL -		FINISH -	DRAWING NO C=MGDQ5-DS	RESTRICTED TO -
CUSTOMER DRAWING		WEIGHT -	SCALE NTS	SHEET 1 of 3

THIS DRAWING IS UNPUBLISHED. RELEASED FOR PUBLICATION
 © COPYRIGHT - By - ALL RIGHTS RESERVED.

LOC		DIST		REVISIONS			
P	LTR	DESCRIPTION	DATE	DWN	APVD		
-	-	SEE SHEET 1	-	-	-		

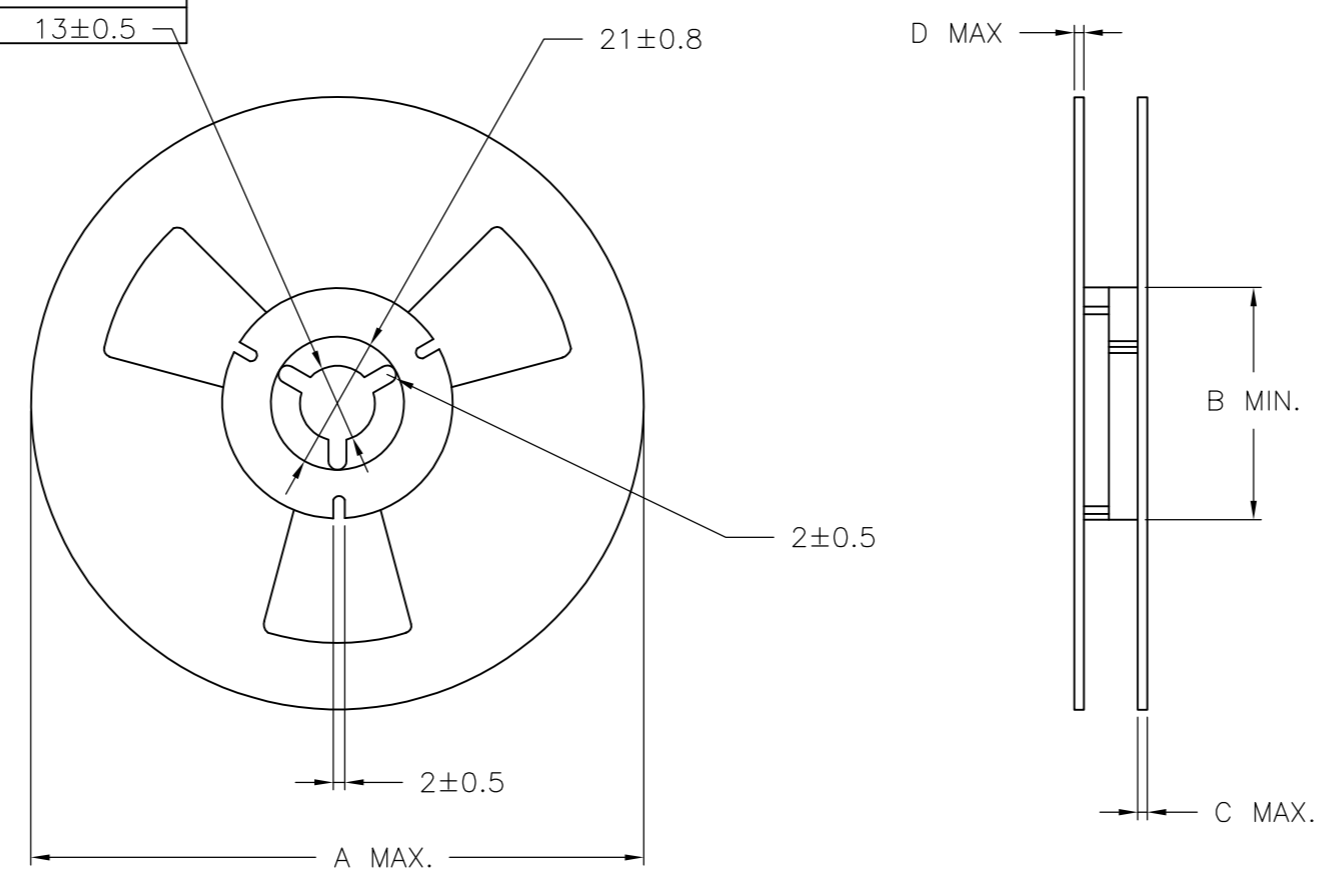

Dimensions are in millimeters unless specified.

Series Number	Maximum Dimensions				Reel Qty	Carton (Box) Qty.	Packaging Specification
	Units	A	B	C			
MGDQ5	inches	12.99"	3.94"	1.16"	650	3250	90-0053
	[mm]	[330]	[100.0]	[29.5]			

PACKAGING NOTE: Only pressure sensitive cover tape is to be used.

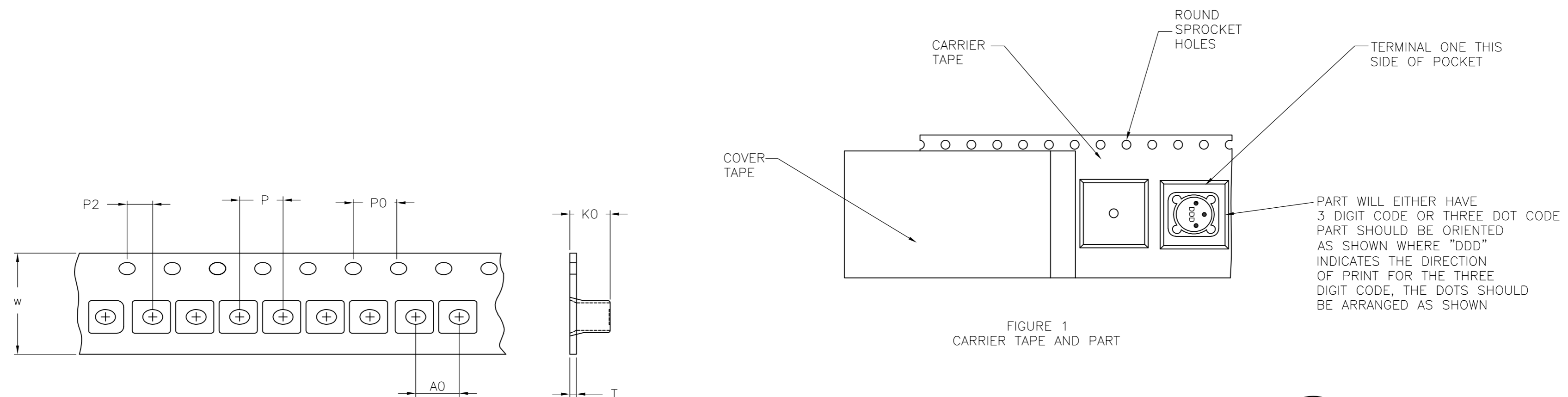

FIGURE 1
CARRIER TAPE AND PART

Series	W ±0.3	P ±0.1	P0 ±0.1	P2 ±0.1	K0 ±0.05	T ±0.05	A0 ±0.1
MGDQ5	24.0	16.0	4.00	2.00	6.30	0.35	12.6

Customer Packaging Specifications
For Print Distribution to Customers



THIS DRAWING IS A CONTROLLED DOCUMENT.		DWN 13FEB2013 RAGHAVENDRA K	TE Connectivity	
DIMENSIONS: INCHES[MM]		CHK 13FEB2013 ALLAN P	MGDQ5 - LOW PROFILE HIGH CURRENT POWER INDUCTOR DATA SHEET	
TOLERANCES UNLESS OTHERWISE SPECIFIED:		APVD 13FEB2013 TONY N	SIZE A2	RESTRICTED TO -
0 PLC ± 0.5		PRODUCT SPEC -	CAGE CODE 00779	DRAWING NO. MGDQ5-DS
1 PLC ± 0.2		APPLICATION SPEC -	SCALE NTS	SHEET 2 of 3
2 PLC ± 0.1		WEIGHT -	REV BA	
3 PLC ± -		CUSTOMER DRAWING		
4 PLC ± -				
ANGLES ± 5				
FINISH -				

THIS DRAWING IS UNPUBLISHED. RELEASED FOR PUBLICATION
 © COPYRIGHT - By - ALL RIGHTS RESERVED.

LOC	DIST	REVISIONS					
E	B	P	LTR	DESCRIPTION	DATE	DWN	APVD
		-	-	SEE SHEET 1	-	-	-

Environmental

Item	Specification	Test Method/Condition
Static Humidity	After exposure part remains within specified electrical parameters for L, Q and DCR.	Precondition at 25°C for 60 minutes. Expose parts to an environment of +40°C with 90 to 95% R.H. for 240 hours.
Storage Life	After exposure part remains within specified electrical parameters for L, Q and DCR.	Subject parts to an environment of 85°C 85% R.H. for 168 hours. After exposure allow parts to dry for 4 hours before measurements are taken.
Temperature Cycle	After exposure part remains within specified electrical parameters for L, Q and DCR.	10 cycles (Air to Air) 1 cycle shall consist of: 30 minutes exposure to +85°C 30 minutes exposure to -40°C Allow 20 minutes transition between extremes.
Temperature Shock	After exposure part remains within specified electrical parameters for L, Q and DCR.	10 cycles (Air to Air) 1 cycle shall consist of: 30 minutes exposure to -55°C 30 minutes exposure to +125°C 15 seconds maximum transition between temperatures
IR Reflow	10 seconds at 260°C max.	Post test parts shall pass all electrical specifications after reflow. There shall be no visible signs of solder flow or leakage from the part.

General

Storage Temperature Range	-40°C to +85°C	
Operating Temperature Range	-40°C to +85°C	
Flammability	IEC 695-2-2	Withstands needle-flame test

Other

Vibration	After exposure part remains within specified electrical parameters for L, Q and DCR.	1 cycle of 30 minutes of the following: 5 - 7 Hz constant displacement of 0.75 inches, 5 minutes 7 - 30 Hz constant acceleration of 1.5 Gs, 10 minutes 31 - 50 Hz constant displacement of 0.33 inches, 5 minutes 50 - 500 Hz constant acceleration of 1.2 Gs, 10 minutes
Mechanical Shock	After exposure part remains within specified electrical parameters for L, Q and DCR.	MGDQ1 Series - 500 Gs per axis, 2 directions MGDQ2 Series - 500 Gs per axis, 2 directions MGDQ3 Series - 500 Gs per axis, 2 directions MGDQ4 Series - 500 Gs per axis, 2 directions MGDQ5 Series - 500 Gs per axis, 2 directions MGDQ6 Series - 500 Gs per axis, 2 directions
Solderability	Wetting shall cover 90% minimum of each termination	Dip pads in SnAgCu solder at 245 ± 5°C for 5 seconds ± 2 seconds.
Component Adhesion (Push Test)	Component shall withstand 6 lb. push force minimum without delaminating from mounting surface.	Apply and measure force with a digital force gauge set

Resistance to Solvent Withstands 6 minutes of alcohol.
 Withstands 3 minutes forced spray Freon TMS

Chemical

Ionic Contamination	Conductivity: pH: Chlorides: Sodium: Potassium:	11 µOhms/cm maximum 5.5 to 9 65 ppm maximum 20 ppm maximum 10 ppm maximum
---------------------	---	---

For Print Distribution to Customers

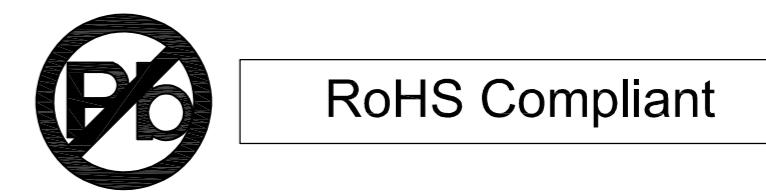

THIS DRAWING IS A CONTROLLED DOCUMENT.		DWN 13FEB2013 RAGHAVENDRA K	TE Connectivity	
DIMENSIONS: INCHES[MM]		CHK 13FEB2013 ALLAN P	NAME	
TOLERANCES UNLESS OTHERWISE SPECIFIED:		APVD 13FEB2013 TONY N	MGDQ5 - LOW PROFILE HIGH CURRENT POWER INDUCTOR DATA SHEET	
0 PLC ± 0.5 1 PLC ± 0.2 2 PLC ± 0.1 3 PLC ± - 4 PLC ± - ANGLES ± 5		PRODUCT SPEC APPLICATION SPEC	SIZE A2	CAGE CODE 00779
MATERIAL	FINISH	WEIGHT -	DRAWING NO. MGDQ5-DS	RESTRICTED TO -
CUSTOMER DRAWING			SCALE NTS	SHEET 3 of 3
			REV BA	