

NOTES:

- MATERIALS : HOUSING - LCP
GLASS FILLED, UL94V-0, COLOR: BLACK
POWER PINS - COPPER ALLOY
SIGNAL PINS - COPPER ALLOY
BOARD LOCK - COPPER ALLOY
- FINISHES: POWER AND SIGNAL PINS
SELECTIVE GOLD IN THE CONTACT AREA
THICKNESS = 0.76 MICROMETER / 30 MICROINCH MINIMUM
SELECTIVE TIN IN THE PC TAIL AREA
THICKNESS = 2.54 MICROMETER / 100 MICROINCH MINIMUM
1.27um MINIMUM NICKEL OVERALL UNDERPLATE.
- PRODUCT SPECIFICATIONS : PS-87631-006
- SEE SHEET 2 FOR RECOMMENDED PCB LAYOUT AND THICKNESS
- COMPONENT STAY AWAY ZONE FROM CONNECTOR
- REFER TO THE TABLE ON TOP OF PAGE 3/3 FOR RECESSED PINS LOCATION
- 24 SIGNAL - 6 POWER CONNECTOR IS SHOWN FOR ILLUSTRATION

ADD P/N: 87667-4019	QUALITY SYMBOLS
EC NO: S2012-0166	▼=0
DRWN:SKANG 2011/08/29	∇=0
CHKD:ATSEE 2011/12/19	
APPR:MLONG 2011/12/22	
REV	DESCRIPTION
D7	

GENERAL TOLERANCES (UNLESS SPECIFIED)	
	mm INCH
4 PLACES	± --- ± ---
3 PLACES	± --- ± .010
2 PLACES	± 0.25 ± ---
1 PLACE	± --- ± ---
ANGULAR ± 3 °	
DRAFT WHERE APPLICABLE MUST REMAIN WITHIN DIMENSIONS	

DIMENSION STYLE	
MM/IN	
DRAWN BY	DATE
BHLOW	2002/11/20
CHECKED BY	DATE
PTLIM	2002/11/26
APPROVED BY	DATE
SKTOH	2002/11/27
MATERIAL NO.	
SEE TABLE	

SCALE	DESIGN UNITS	THIRD ANGLE PROJECTION
NTS	METRIC	
TITLE		
EXTREME POWERPLUS S-P(B) HEADER R/A, T/H, SCREW-MOUNT		
MOLEX INCORPORATED		
DOCUMENT NO.		SHEET NO.
SD-87667-010		1 OF 3
THIS DRAWING CONTAINS INFORMATION THAT IS PROPRIETARY TO MOLEX INCORPORATED AND SHOULD NOT BE USED WITHOUT WRITTEN PERMISSION		

10 9 8 7 6 5 4 3 2 1

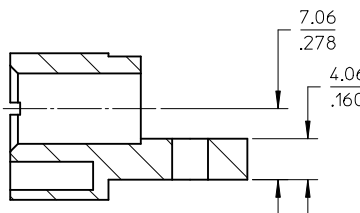

SECTION X-X

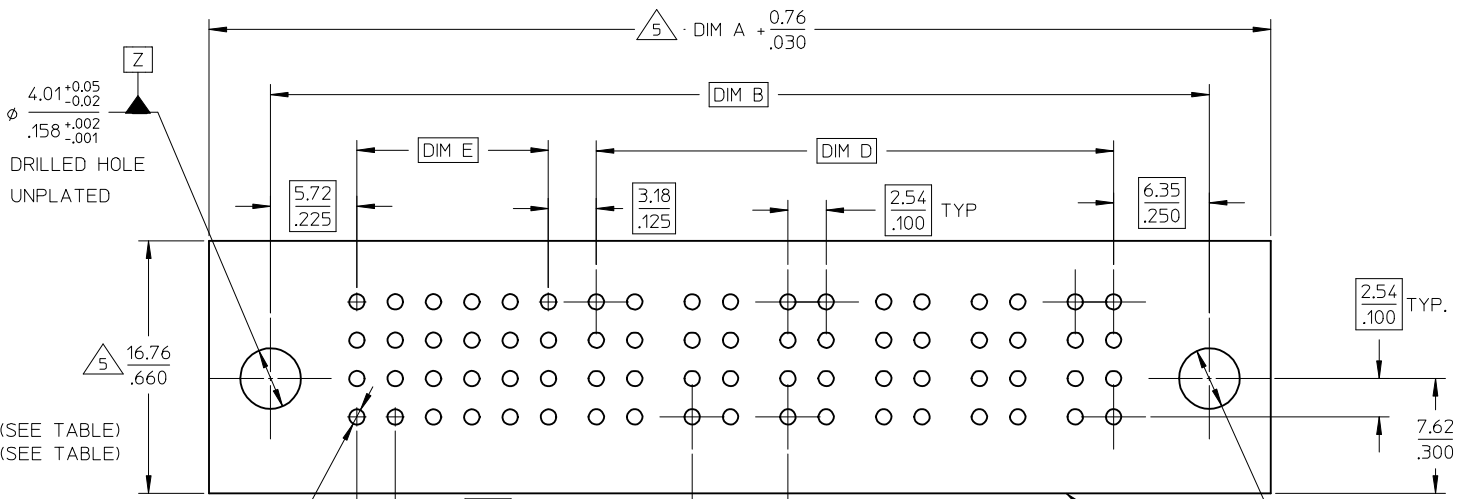

RECOMMENDED PCB LAYOUT

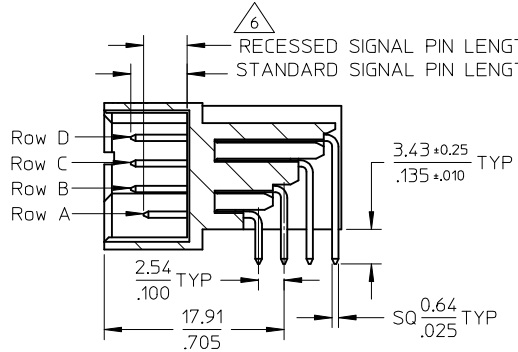

SECTION Y-Y

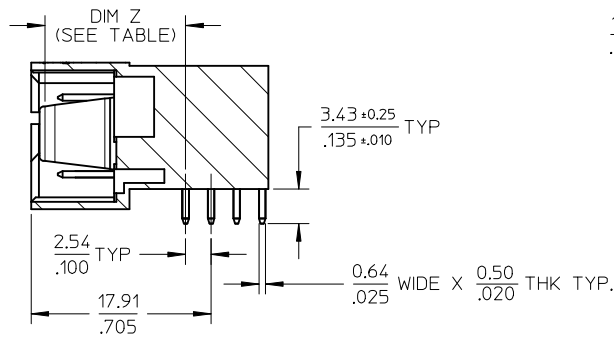

SECTION Z-Z

ADD P/N: 87667-4019
 EC NO: S2012-0166
 DRWNS:KANG 2011/08/29
 CHKD:ATSEE 2011/12/19
 APPR:MLONG 2011/12/22

REV	DESCRIPTION

QUALITY SYMBOLS $\nabla = 0$ $\triangleleft = 0$	GENERAL TOLERANCES (UNLESS SPECIFIED)	
	mm	INCH
	4 PLACES ± --- ± ---	3 PLACES ± --- ± .010
	2 PLACES ± 0.25 ± ---	1 PLACE ± --- ± ---
ANGULAR ± 3°		
DRAFT WHERE APPLICABLE MUST REMAIN WITHIN DIMENSIONS		

DIMENSION STYLE MM/IN	
DRAWN BY BHLW	DATE 2002/11/20
CHECKED BY PTLIM	DATE 2002/11/26
APPROVED BY SKTOH	DATE 2002/11/27
MATERIAL NO. SEE TABLE	

SCALE NTS	DESIGN UNITS METRIC	THIRD ANGLE PROJECTION
TITLE EXTREME POWERPLUS S-P(B) HEADER R/A, T/H, SCREW-MOUNT		
MOLEX INCORPORATED		SHEET NO. 2 OF 3
DOCUMENT NO. SD-87667-010		

9 8 7 6 5 4 3 2 1

PART NUMBER	S-P CONFIGURATION		DIMENSIONS					POWER BLADE OPTIONS		STANDARD SIGNAL	RECESSED SIGNAL PIN	VOID PIN LOCATION	VOID POWER LOCATION	PACKAGING
	SIGNAL	POWER BETA	DIM A	DIM B	DIM C	DIM D	DIM E	TYPE	DIM Z ±0.13/.005	PIN LENGTH	LENGTH	LOCATION		
87667-4002	24	6	69.85 2.750	62.23 2.450	60.96 2.400	34.29 1.350	12.70 .500	SHORT CONTACT	13.32 / .524	5.59 / .220	4.32 / .170	NIL	NIL	TRAY
87667-4004	16	4	52.07 2.050	44.45 1.750	43.18 1.700	21.59 .850	7.62 .300	LONG CONTACT	14.12 / .556	6.86 / .270	5.59 / .220	A1	NIL	TRAY
87667-4005	24	6	69.85 2.750	62.23 2.450	60.96 2.400	34.29 1.350	12.70 .500	LONG CONTACT	14.12 / .556	6.86 / .270	5.59 / .220	A1, A2 B1, B2 C1, C2 D1, D2	NIL	TRAY
87667-4006	24	6	69.85 2.750	62.23 2.450	60.96 2.400	34.29 1.350	12.70 .500	LONG CONTACT	14.12 / .556	6.86 / .270	5.59 / .220	NIL	NIL	TRAY
87667-4007	24	10	95.25 3.750	87.63 3.450	86.36 3.400	59.69 2.350	12.70 .500	LONG CONTACT	14.12 / .556	6.86 / .270	5.59 / .220	NIL	NIL	TRAY
87667-4008	24	8	82.55 3.250	74.93 2.950	73.66 2.900	46.99 1.850	12.70 .500	LONG CONTACT	14.12 / .556	6.86 / .270	5.59 / .220	NIL	NIL	TRAY
87667-4009	24	12	107.95 4.250	100.33 3.950	99.06 3.900	72.39 2.850	12.70 .500	LONG CONTACT	14.12 / .556	6.86 / .270	5.59 / .220	NIL	NIL	TRAY
87667-4010	24	8	82.55 3.250	74.93 2.950	73.66 2.900	46.99 1.850	12.70 .500	LONG CONTACT	14.12 / .556	6.86 / .270	5.59 / .220	B4	NIL	TRAY
87667-4011	24	6	69.85 2.750	62.23 2.450	60.96 2.400	34.29 1.350	12.70 .500	LONG CONTACT	14.12 / .556	6.86 / .270	5.59 / .220	A1	NIL	TRAY
87667-4012	24	6	69.85 2.750	62.23 2.450	60.96 2.400	34.29 1.350	12.70 .500	LONG CONTACT	14.12 / .556	6.86 / .270	5.59 / .220	B4	NIL	TRAY
87667-4013	20	4	54.61 2.150	46.99 1.850	45.72 1.800	21.59 .850	10.16 .400	LONG CONTACT	14.12 / .556	6.86 / .270	5.59 / .220	A1, A5	A4,B4 C4,D4	TRAY
87667-4014	20	6	67.31 2.650	59.69 2.350	58.42 2.300	34.29 1.350	10.16 .400	LONG CONTACT	14.12 / .556	6.86 / .270	5.59 / .220	B4	NIL	TRAY
87667-4015	24	6	69.85 2.750	62.23 2.450	60.96 2.400	34.29 1.350	12.70 .500	LONG CONTACT	14.12 / .556	6.86 / .270	5.59 / .220	A1 B5 C5 D5	NIL	TRAY
87667-4017	24	7	76.20 3.000	68.58 2.700	67.31 2.650	40.64 1.600	12.70 .500	LONG CONTACT	14.12 / .556	6.86 / .270	5.59 / .220	NIL	NIL	TRAY
87667-4019	24	10	95.25 3.750	87.63 3.450	86.36 3.400	59.69 2.350	12.70 .500	LONG CONTACT	14.12 / .556	6.86 / .270	5.59 / .220	NIL	NIL	B#1 TRAY

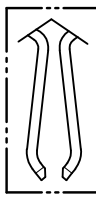

SHORT BLADE OPTION

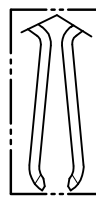

LONG BLADE OPTION

DETAIL R
(SEE TABLE FOR BLADE OPTION)

ADD P/N: 87667-4019
EC NO: S2012-0166
DRWN:SKANG 2011/08/29
CHKD:ATSEE 2011/12/19
APPR:MLONG 2011/12/22

QUALITY SYMBOLS
▽=0
◁=0

GENERAL TOLERANCES (UNLESS SPECIFIED)

	mm	INCH
4 PLACES	± .010	± .0004
3 PLACES	± .015	± .0006
2 PLACES	± 0.25	± .010
1 PLACE	± .005	± .0002
ANGULAR ± 3°		

DIMENSION STYLE
MM/IN

DRAWN BY: BHLW DATE: 2002/11/20
CHECKED BY: PTLIM DATE: 2002/11/26
APPROVED BY: SKTOH DATE: 2002/11/27

MATERIAL NO. SEE TABLE
DOCUMENT NO. SD-87667-010

SCALE: NTS
DESIGN UNITS: METRIC

THIRD ANGLE PROJECTION

TITLE: **EXTREME POWERPLUS S-P(B) HEADER R/A, T/H, SCREW-MOUNT**

MOLEX INCORPORATED

SHEET NO. 3 OF 3

DRAFT WHERE APPLICABLE MUST REMAIN WITHIN DIMENSIONS

THIS DRAWING CONTAINS INFORMATION THAT IS PROPRIETARY TO MOLEX INCORPORATED AND SHOULD NOT BE USED WITHOUT WRITTEN PERMISSION