

PART NUMBER	REV	FIRST USED
680220-1	B	122500-1
680220-2	B	565435-5
680220-3	B	354500-1

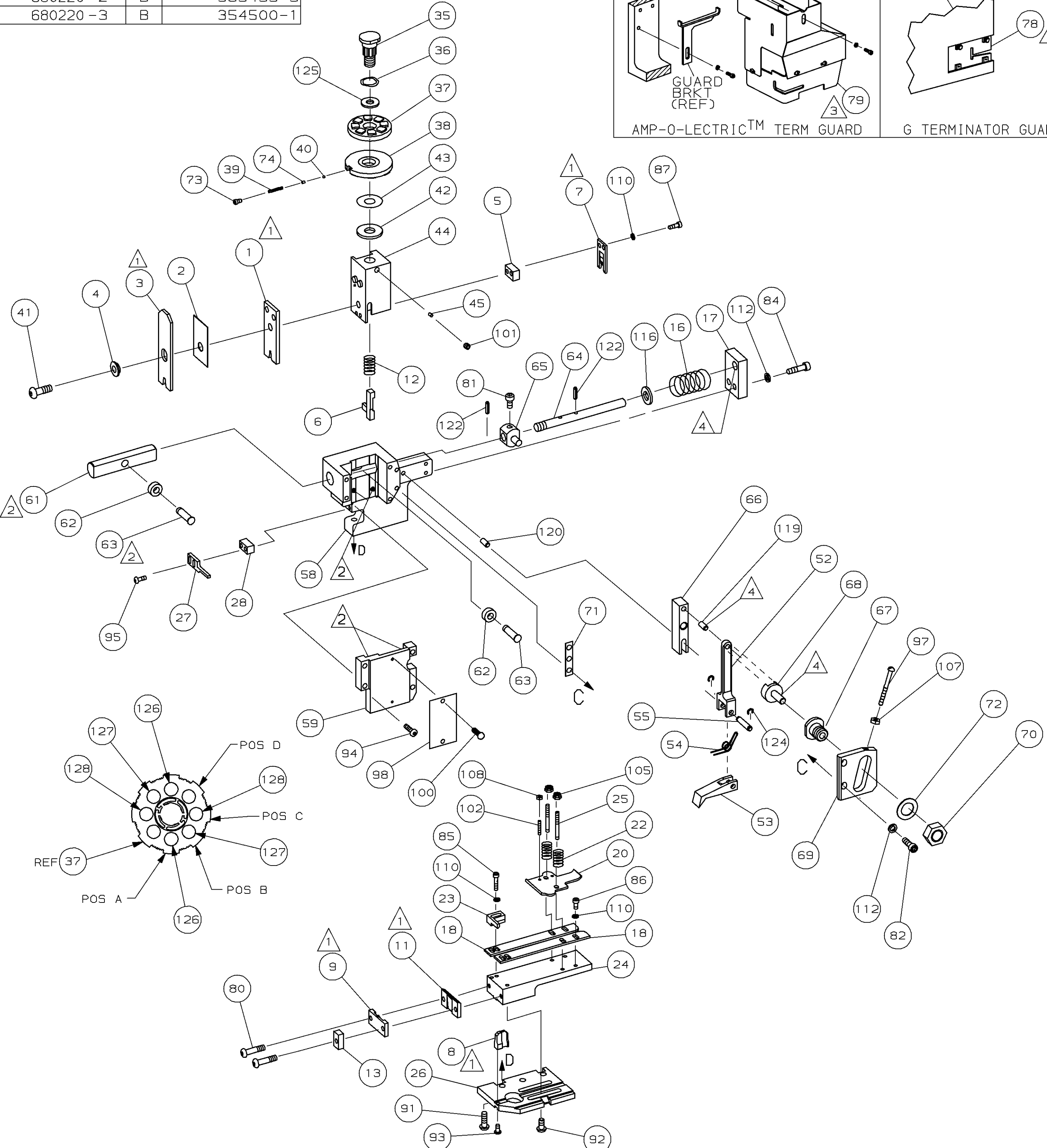
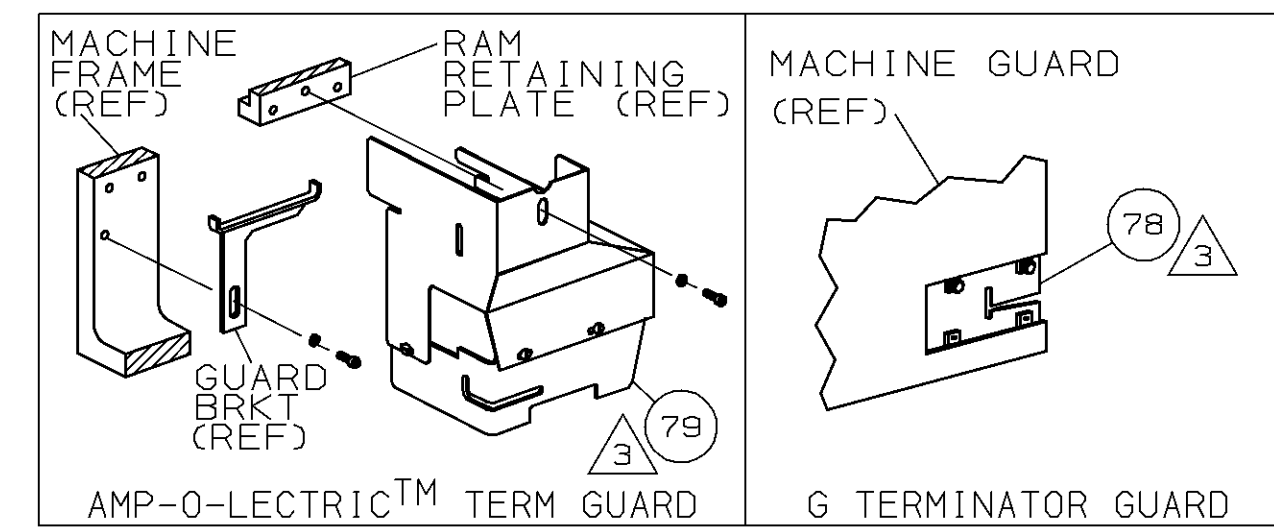

TERMINAL NAME: TERMINAL CONTACT FOR 5mm PITCH CONNECTOR			
282308			
CRIMPING DATA			
PAD LTR	CRIMP HEIGHT	WIRE SIZE	
A	.058 ±.002 [1.47 ±0.05mm]	1.5mm ² OR 1mm ²	
B	.054 ±.002 [1.37 ±0.05mm]	0.75mm ²	
C	.052 ±.002 [1.32 ±0.05mm]	0.5mm ²	
D	NOT	USED	
CRIMP		SIZE	TYPE RANGE
WIRE		.080 [2.03mm]	F 0.5 - 1.5mm ²
INSUL		.130 [3.30mm]	F ø3.35mm MAX
WIRE STRIP LENGTH	TERM APPL SPEC	FEED	APPL INSTRUCTION SET UP GAGE LAYOUT
-	114-20058	.787	458638-1 L1692

-1 LEADMAKER		MECH POST FEED	
-2	BENCH MODEL K	MECH PRE FEED	
-3	BENCH MODEL G	MECH PRE FEED	
REF	REF	REF	REF
-	A	22594-8	NUT, HEX
REF	REF	REF	REF
-	B	240628-1	PLATE, ADJ
REF	REF	REF	REF
-	B	240626-1	SHAFT, PIVOT
REF	REF	REF	REF
-	B	240633-1	BUSHING
REF	REF	REF	REF
-	A	455680-1	LEVER, INTERMEDIATE
REF	REF	REF	REF
-	B	240629-1	BLOCK, PIVOT
REF	REF	REF	REF
-	A	240632-2	SCR, ADJ
REF	REF	REF	REF
-	B	240659-3	PIN, CAM ROLLER
REF	REF	REF	REF
-	B	240658-1	CAM, ROLLER
REF	REF	REF	REF
-	B	454398-1	ROD, FEED

2	2	2	-	C	2-354779-5	PIN, WIRE DISC (.3115)C	129
2	2	2	-	C	2-354779-0	PIN, WIRE DISC (.3090)B	127
2	2	2	-	C	1-354779-2	PIN, WIRE DISC (.3050)A	126
1	1	1	-	A	986950-1	WASHER, FLAT PRECISION	125
REF	REF	REF	-	A	21045-3	RING, RET "C" (ø.187)FD PIN	124
REF	REF	REF	-	A	5-21028-1	PIN, STD SPRING (ø.12)FD ADJ ROD	122
REF	REF	REF	-	A	1-21030-7	PIN, DOWEL (ø.187x1.50)HSG	120
REF	REF	REF	-	A	1-21030-1	PIN, DOWEL (ø.187x.50)LEVER	119
REF	REF	REF	-	A	21899-4	WASHER, FLAT (ø5/16)SCR ADJ	116
REF	REF	REF	-	A	21024-5	WASHER, LOCK (NO.10)FD ROD GDE	112
7	7	7	-	A	21024-4	WASHER, LOCK (NO.8)SHEAR BL	110
2	2	2	-	A	21018-4	NUT, HEX (4-40)DRAG	109
REF	REF	REF	-	A	21018-5	NUT, HEX (6-32)FD ADJ PL	107
2	2	2	-	A	21022-2	NUT, HEX SL (8-32)DRAG STUD	105
2	2	2	-	A	2-21006-6	SCR, SKT SET (4-40x.62)DRAG	102
1	1	1	-	A	21009-2	SCR, SKT SET (1/4-20x.25)RAM	101
2	2	2	-	A	21017-2	SCR, DRIVE (#2x.19) ID PLATE	100
1	1	1	-	A	1-21002-7	SCR, BHC (6-32x.38)CAM	99
1	1	1	-	B	461264-1	PLATE, IDENTIFICATION	98
REF	REF	REF	-	A	6-23715-5	SCR, PAN HD (6-32x1.50)FEED ADJ	97
REF	REF	REF	-	A	2-21002-2	SCR, BHC (8-32x.50)STRIPPER	95
REF	REF	REF	-	A	2-21002-9	SCR, BHC (10-32x.75)HSG CAP	94
1	1	1	-	A	22733-8	SCR, BHC (8-32x.38 LW)ANVIL	93
4	4	4	-	A	3-21002-3	SCR, BHC (1/4-20x.50)ST GD PL	92
REF	REF	REF	-	A	2-22733-8	SCR, BHC (1/4-20x.62)BASE PL	91
REF	REF	REF	-	A	2-21000-7	SCR, SHC (8-32x.50)SLUG BLADE	87
3	3	3	-	A	2-21000-5	SCR, SHC (8-32x.25)STRIP GUIDE	86
2	2	2	-	A	2-21000-9	SCR, SHC (8-32x.75)R STRIP GUIDE	85
REF	REF	REF	-	A	3-21000-7	SCR, SHC (10-32x.75)FEED ROD GDE	84
REF	REF	REF	-	A	3-21000-6	SCR, SHC (10-32x.62)FEED ADJ PL	82
REF	REF	REF	-	A	3-21000-4	SCR, SHC (10-32x.38)PIVOT BLOCK	81
2	2	2	-	A	3-21002-0	SCR, BHC (10-32x.88)SHEAR PL	80
-	REF	-	-	A	455745-1	GUARD, WINDOW	79
REF	-	-	-	A	679532-1	INSERT, GUARD	78
1	1	1	-	A	690603-1	SPRING, ASSIST	74
1	1	1	-	A	23030-1	SCR, SKT CAP (6-32x.25)CP DSC	73
REF	REF	REF	-	A	458109-1	WASHER, FLAT (SPECIAL)	72
REF	REF	REF	-	A	690517-1	SPACER	71

REF	REF	REF	-	C	454220-1	CAP, RAM	59
REF	REF	REF	-	D	453736-1	HOUSING	58
REF	REF	REF	-	B	240624-1	PIN, FEED FINGER	55
REF	REF	REF	-	B	691499-1	SPRING, FEED FINGER	54
REF	REF	REF	-	B	240635-1	FINGER, FEED	53
REF	REF	REF	-	B	240634-1	LEVER, TERMINAL	52
1	-	-	-	B	690602-6	CAM, PRE-FEED 1 5/8 ST	49
-	1	-	-	B	690602-5	CAM, PRE-FEED 1 1/8 ST	48
-	-	1	-	B	690501-4	CAM, POST-FEED 1 5/8 ST	47
1	1	1	-	A	690191-1	PLUG, NYLON	45
1	1	1	-	C	455674-1	RAM	44
1	1	1	-	A	690125-1	WASHER, LAMINATED	43
1	1	1	-	A	690124-1	WASHER, RAM	42
1	1	1	-	A	7-21002-9	BOLT, CRIMPER (5/16-24x1.00)	41
1	1	1	-	A	23241-6	BALL, STEEL	40
1	1	1	-	A	690170-1	SPRING, COMPRESSION	39
1	1	1	-	C	690142-1	DISC, INSULATION	38
1	1	1	-	D	354777-1	WIRE DISC, PLASTIC	37
1	1	1	-	A	22480-5	WASHER, SPRING	36
1	1	1	-	B	690212-1	POST, RAM	35
1	1	1	-	D	458980-1	APPLICATOR, BASIC (SUB ASSY)	32
1	1	1	-	B	3-690451-7	SPACER, STRIPPER	28
1	1	1	-	A	240639-1	STRIPPER	27
REF	REF	REF	-	C	455676-1	PLATE, BASE	26
2	2	2	-	A	22354-8	DRAG, STUD	25
1	1	1	-	B	455678-2	PLATE, STRIP GUIDE	24
1	1	1	-	C	240825-4	PLATE, STRIP HOLD DOWN	23
2	2	2	-	A	4-22281-1	SPRING, DRAG	22
1	1	1	-	A	454177-1	DRAG, STOCK	20
2	2	2	-	C	454204-3	GUIDE, STRIP (FRONT)	18
REF	REF	REF	-	A	454178-1	GUIDE, FEED ROD	17
REF	REF	REF	-	A	4-22284-9	SPRING, FEED RETURN	16
1	1	1	-	C	690481-2	SPACER, HOLD DOWN	13
1	1	1	-	A	23846-1	SPRING, HOLD DOWN	12
1	1	1	-	B	240644-1	PLATE, REAR SHEAR	11
1	1	1	-	B	690482-4	PLATE, FRONT SHEAR	9
1	1	1	-	D	4-461295-5	ANVIL	8
1	1	1	-	B	690474-4	BLADE, SLUG	7
1	1	1	-	D	455892-6	HOLD DOWN, TERMINAL	6
1	1	1	-	C	2-240641-4	SPACER, SLUG BLADE	5
1	1	1	-	B	238009-8	SPACER, BLOCK CRIMPER	4
1	1	1	-	C	4-456134-4	CRIMPER, INSULATION	3
1	1	1	-	B	455888-6	SPACER, CRIMPER	2
1	1	1	-	C	2-456405-7	CRIMPER, WIRE	1

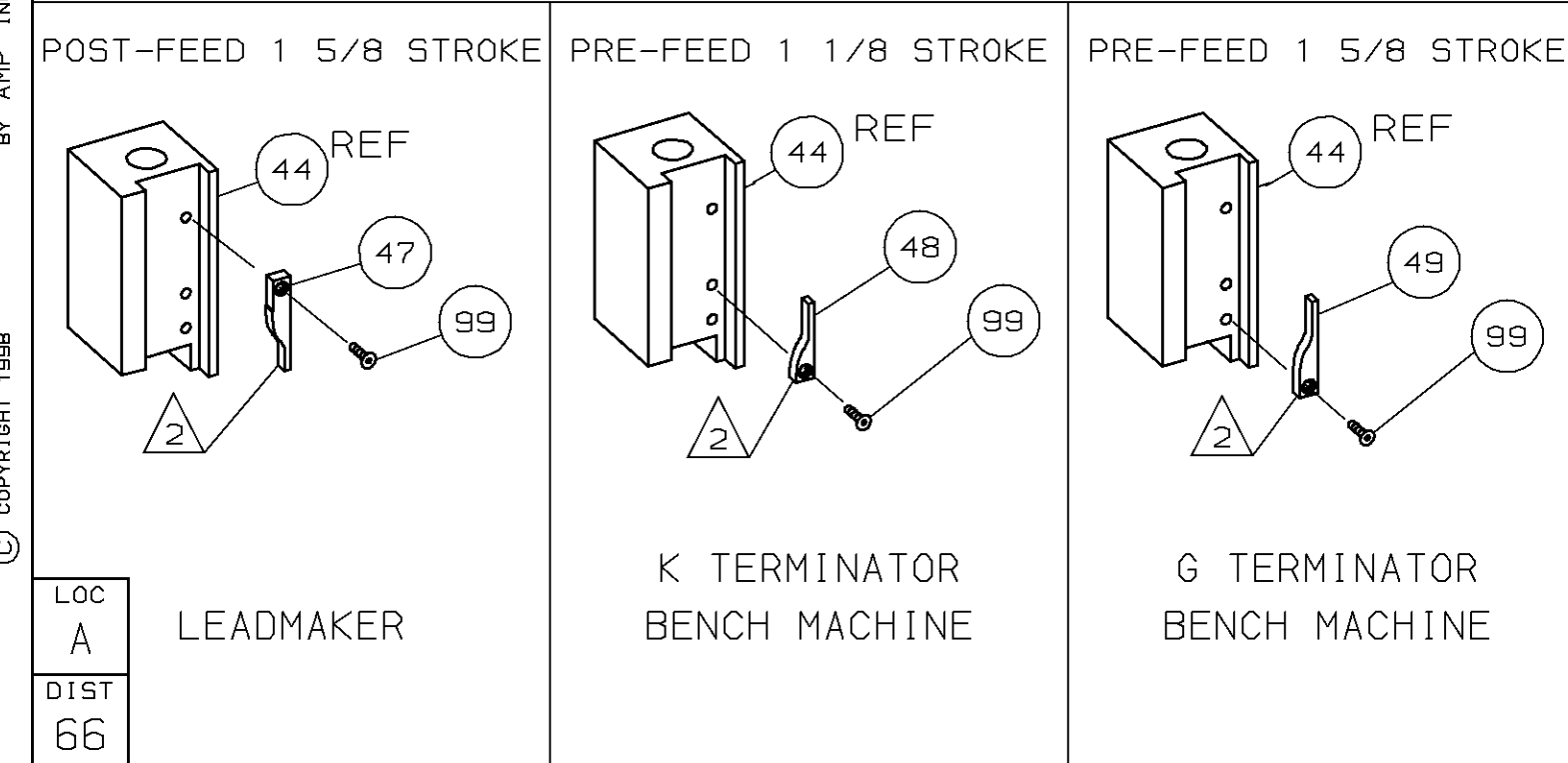

- 1 RECOMMENDED SPARE PARTS.
- 2 GREASE LIGHTLY.
- 3 GUARD MUST BE IN PLACE WHEN OPERATING APPLICATOR IN A BENCH MACHINE.
- 4 LUBRICATE DAILY USING NO. 20 MACHINE OIL.
- 5. ITEMS WITH QTY OF REF SPECIFIED (EXCEPT ITEMS 78 AND 79) ARE USED ON ITEM 32.

THIS DRAWING IS A CONTROLLED DOCUMENT

THIS DRAWING IS UNPUBLISHED. RELEASED FOR PUBLICATION BY AMP INCORPORATED. ALL INTERNATIONAL RIGHTS RESERVED. MARI7, 1998