

7879-1(***)*		7879-2(***)*	
PART NO.	ENG. NO	PART NO.	ENG. NO
08-55-0124	7879-1(P208)	50-29-1744	7879-2(P228)
08-55-0129	7879-1(P208)L	50-29-1745	7879-2(P228)L
08-50-0004	7879-1(P102)		
08-50-0005	7879-1(P102)L		
50-29-1900	7879-1(P154)		
46999-0101	7879-1(P154)L		

NOTES:

1. MATERIAL: SEE LEGEND.
2. FINISH: SEE LEGEND.
3. THIS PART CONFORMS TO PRODUCT SPEC. 7879.
4. PACKAGING SPECIFICATION: SEE LEGEND
5. CRIMP FOR 24-30 AWG. WIRE WITH .060(1.52) MAX. INSULATION DIA.
6. THIS TERMINAL TO BE USED IN 7880 HOUSING.
7. DIMENSIONS GIVEN ACROSS CENTERLINES ARE SYMMETRICAL ABOUT THOSE CENTERLINES WITHIN HALF THE TOTAL TOLERANCE.
8. CRIMP WILL ACCEPT 22 AWG. WIRE WITH .062(1.57) MAX. INSULATION DIA.
9. THIS PART CONFORMS TO CLASS B REQUIREMENTS OF COSMETIC SPECIFICATION PS-45499-002.

LEGEND:

7879-\*(\*\*\*)\*

MATERIAL .008/ (0.20) THICK  
 1 = BRASS  
 2 = PHOS. BRONZE

FORM  
 BLANK = REEL, PER WINDING DETAIL B  
 L = LOOSE, PER PK-2759-001

PLATING

- (102) OVERALL TIN: .000200/(0.00508) MIN. OVER .000100/(0.00254) MIN. COPPER.  
 (P154) OVERALL TIN: .000100/(0.00254) MIN. OVERALL NICKEL UNDERPLATE: .000050/(0.00127) MIN.  
 (208) SELECT GOLD: .000015/(0.00038) MIN.  
 SELECT TIN: .000100/(0.00254) MIN.
- (228) OVERALL NICKEL UNDERPLATE: .000050/(0.00127) MIN.  
 SELECT GOLD: .000030/(0.00076) MIN.  
 SELECT TIN: .000100/(0.00254) MIN.  
 OVERALL NICKEL UNDERPLATE: .000050/(0.00127) MIN.

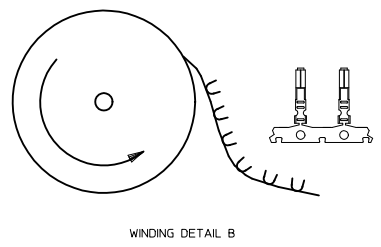
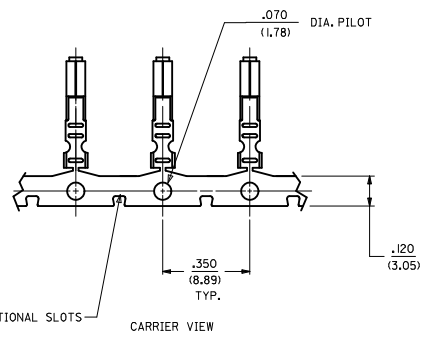
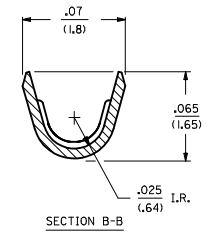
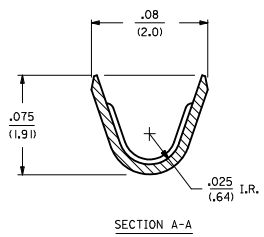
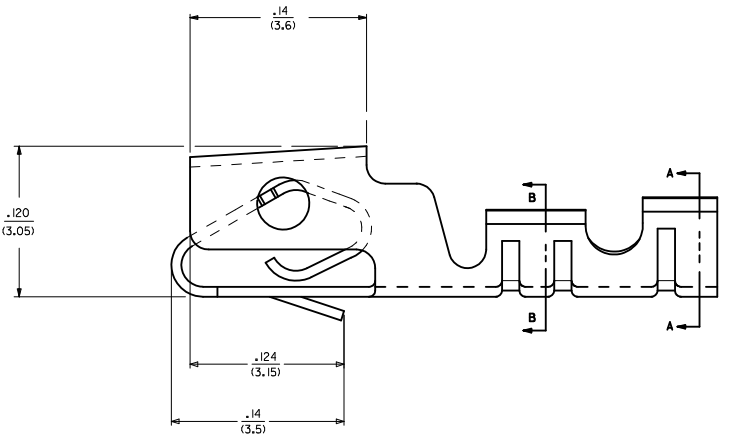
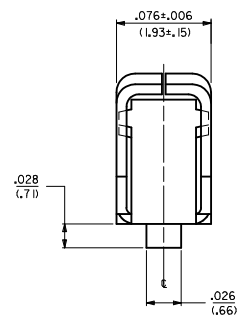
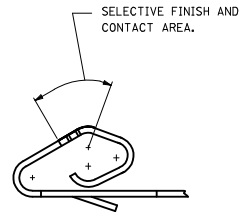
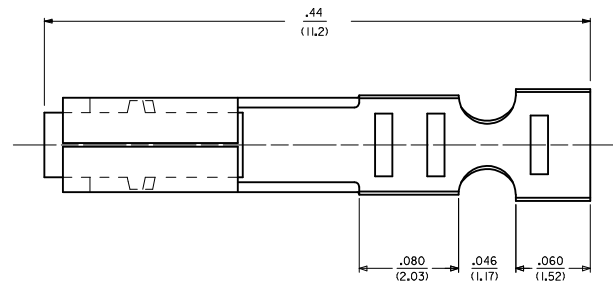

ADD 46999-0101 IEC NO. UCF2011-1803 DRAWN BY: CHYKOSOUSEK CHECKED BY: APPR:FSM/TH DATE: 2011/03/02 DATE: 2011/03/04 DATE: 2011/03/10	QUALITY SYMBOLS	GENERAL TOLERANCES (UNLESS SPECIFIED)	DIMENSION STYLE	SCALE	DESIGN UNITS	THIRD ANGLE PROJECTION
	▽=0	mm INCH	IN/MM	---	INCH	
	▽=0	4 PLACES ± --- ± ---	DRAWN BY: GUZIK	DATE: 12/22/88	TITLE: (2.54)/100 KK. CRIMP TYPE SHROUDED TERMINAL	
	▽=0	3 PLACES ± --- ± .10	CHECKED BY: PATEL	DATE: 12/22/88	MOLEX INCORPORATED	
		2 PLACES ± 0.25 ± .014	APPROVED BY: LENZ	DATE: 12/22/88	DOCUMENT NO. SD-7879	SHEET NO. 1 OF 1
		1 PLACE ± 0.36 ± ---	MATERIAL NO. SEE CHART			
		ANGULAR ±1/2°	DRAFT WHERE APPLICABLE MUST REMAIN WITHIN DIMENSIONS			