

## Product Brief

# Infineon's New LTE Low Noise Amplifiers Almost Double Smartphone Data Rates

Improving the user experience by improving smartphone data rates by up to 96% is the boast of Infineon for its LTE LNA (low noise amplifiers) and quad LNA banks. The BGA7x1N6 and BGM7xxx4L12 families provide a low noise figure, the exact gain and high linearity needed to help smartphone designers overcome the challenges of LTE or 4G which allows for data rates up to 300Mbit/s – compared to 56Mbit/s in the latest UMTS (3G) release. However, the increasing complexity of the RF front end results in more RF components (e.g. switches, diplexers and dividers) and leads to increasing losses over the whole system and deterioration of the signal-to-noise ratio (SNR). The distance between antenna and the RF transceiver leads to additional line losses that also negatively affect SNR and therefore the data rate.

The LNAs and LNA banks are based on the company's Silicon Germanium Carbon (SiGe:C) chip technology and include built-in ESD protection of 2kV HBM.

They are located in the diversity and main antenna path of the phone and push smartphone data rates' limits 96% higher than in solutions without LNAs. High linearity assures optimal signal reception even in conditions of poorly isolated antenna and long line losses between antenna and transceiver. The typical sensitivity improvement of 3.4dB compared to systems without LNAs is achieved in devices with a package size 70% smaller ( $1.1 \times 0.7\text{mm}^2$ ) than previously available LNAs and 61% smaller ( $1.9 \times 1.1\text{mm}^2$ ) than previously available LNA banks.

The products are also self-shielded to prevent parasitic interference and require only one external component per LNA.

There are three LTE LNAs and seven quad LNA bank families to address the required band configurations for different world regions, each letter in the series denotes a different frequency band: L for the low, 0.7GHz to 1GHz band; M for mid, 1.7GHz to 2.2GHz band; and H for high, 2.3GHz to 2.7GHz band.

They are shipped in RoHS-compliant TSNP-6-2 or TSLP 12-4 plastic packages.

### Key Features

- High linearity
- Best-in-class noise figure
- Low current consumption
- Supply voltage: 1.5V to 3.3V
- Ultra small
  - Single LNAs:  
TSNP-6-2 leadless package  
(footprint:  $1.1 \times 0.7\text{mm}^2$ )
  - Quad LNA banks:  
TSLP-12-4 leadless package  
(footprint:  $1.1 \times 1.9\text{mm}^2$ )
- B7HF Silicon Germanium Carbon (SiGe:C) technology
- RF output internally matched to  $50\Omega$
- Low external component count
- 2kV HBM ESD protection
- Pb-free (RoHS compliant) package

### Applications

- Smartphones
- Tablets
- Datacards
- M2M communication

# Infineon's New LTE Low Noise Amplifiers Almost Double Smartphone Data Rates

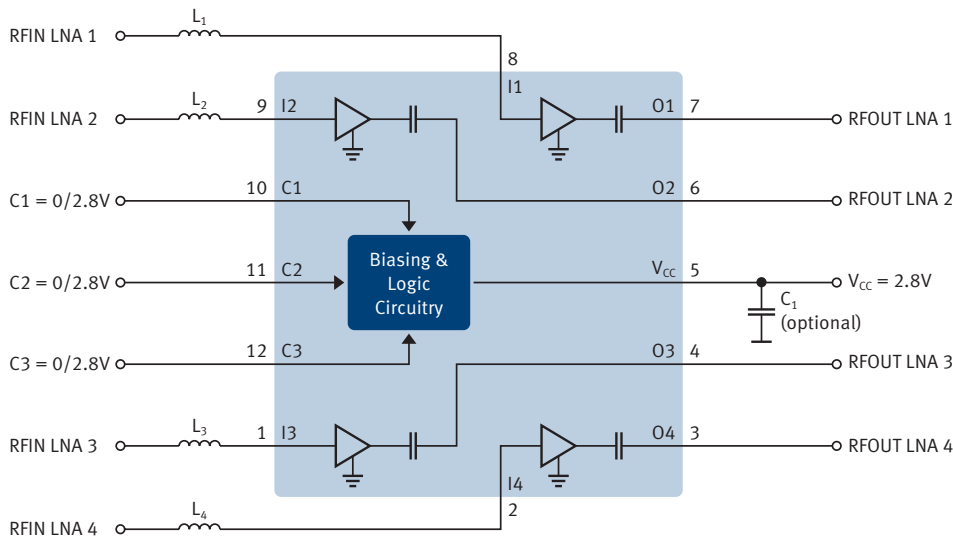
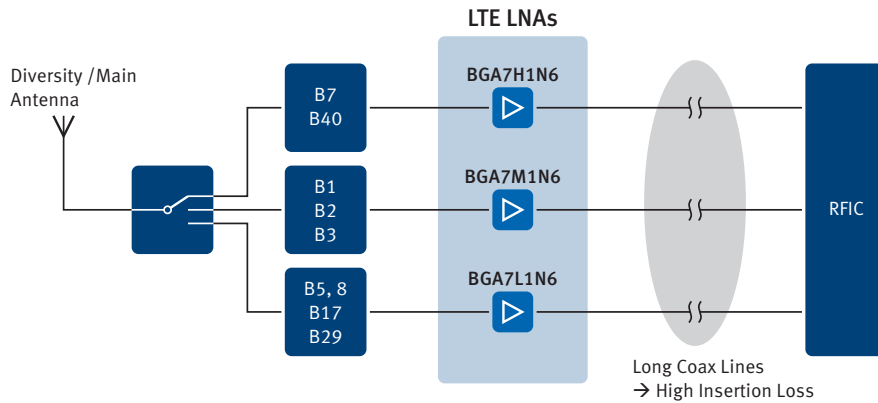

## Ordering no. (SP numbers)

- BGM7LLHM4L12: BGM7LLHM4L12E6327XTSA1
- BGM7MLLH4L12: BGM7MLLH4L12E6327XTSA1
- BGM7MLLM4L12: BGM7MLLM4L12E6327XTSA1
- BGM7LMHM4L12: BGM7LMHM4L12E6327XTSA1
- BGM7HHMH4L12: BGM7HHMH4L12E6327XTSA1
- BGA7L1N6: BGA7L1N6E6327XTSA1
- BGA7M1N6: BGA7M1N6E6327XTSA1
- BGA7H1N6: BGA7H1N6E6327XTSA1

Published by  
Infineon Technologies AG  
85579 Neubiberg, Germany

© 2014 Infineon Technologies AG.  
All Rights Reserved.

Visit us:  
[www.infineon.com](http://www.infineon.com)

Order Number: B132-H9894-X-X-7600  
Date: 04 / 2014

### Attention please!

The information given in this document shall in no event be regarded as a guarantee of conditions or characteristics ("Beschaffenheitsgarantie"). With respect to any examples or hints given herein, any typical values stated herein and/or any information regarding the application of the device, Infineon Technologies hereby disclaims any and all warranties and liabilities of any kind, including without limitation warranties of non-infringement of intellectual property rights of any third party.

### Information

For further information on technology, delivery terms and conditions and prices please contact your nearest Infineon Technologies Office ([www.infineon.com](http://www.infineon.com)).

### Warnings

Due to technical requirements components may contain dangerous substances. For information on the types in question please contact your nearest Infineon Technologies Office. Infineon Technologies Components may only be used in life-support devices or systems with the express written approval of Infineon Technologies, if a failure of such components can reasonably be expected to cause the failure of that life-support device or system, or to affect the safety or effectiveness of that device or system. Life support devices or systems are intended to be implanted in the human body, or to support and/or maintain and sustain and/or protect human life. If they fail, it is reasonable to assume that the health of the user or other persons may be endangered.