

THIS DRAWING IS UNPUBLISHED. RELEASED FOR PUBLICATION
 © COPYRIGHT BY TYCO ELECTRONICS CORPORATION. ALL RIGHTS RESERVED.

LOC	DIST	REVISIONS			
P	LTR	DESCRIPTION	DATE	DWN	APVD
CM	0	H	ECO-06-012706	08JUN06	BSV JR

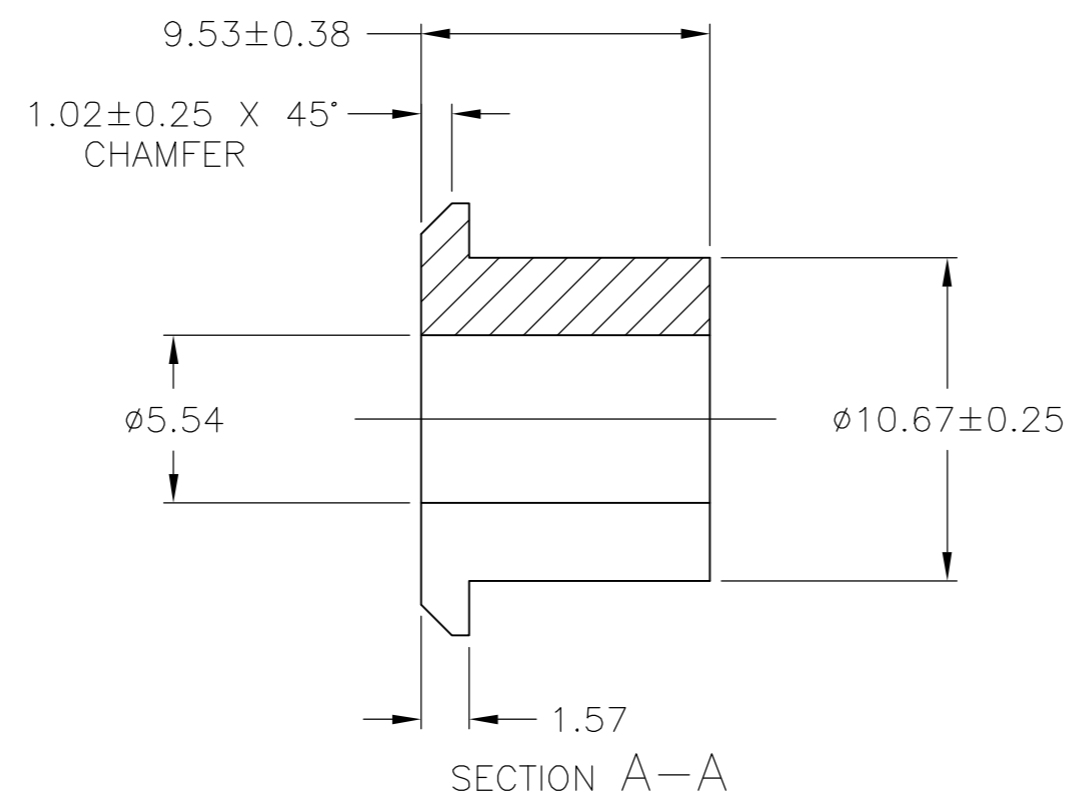

1. USE WITH STRAIN RELIEF 350374.
2. MOLDING COMPOUND PVC,FLEXIBLE, 55/75 DUROMETER (B SCALE),BLACK.
3. MOLDING COMPOUND PVC,FLEXIBLE,BLACK.

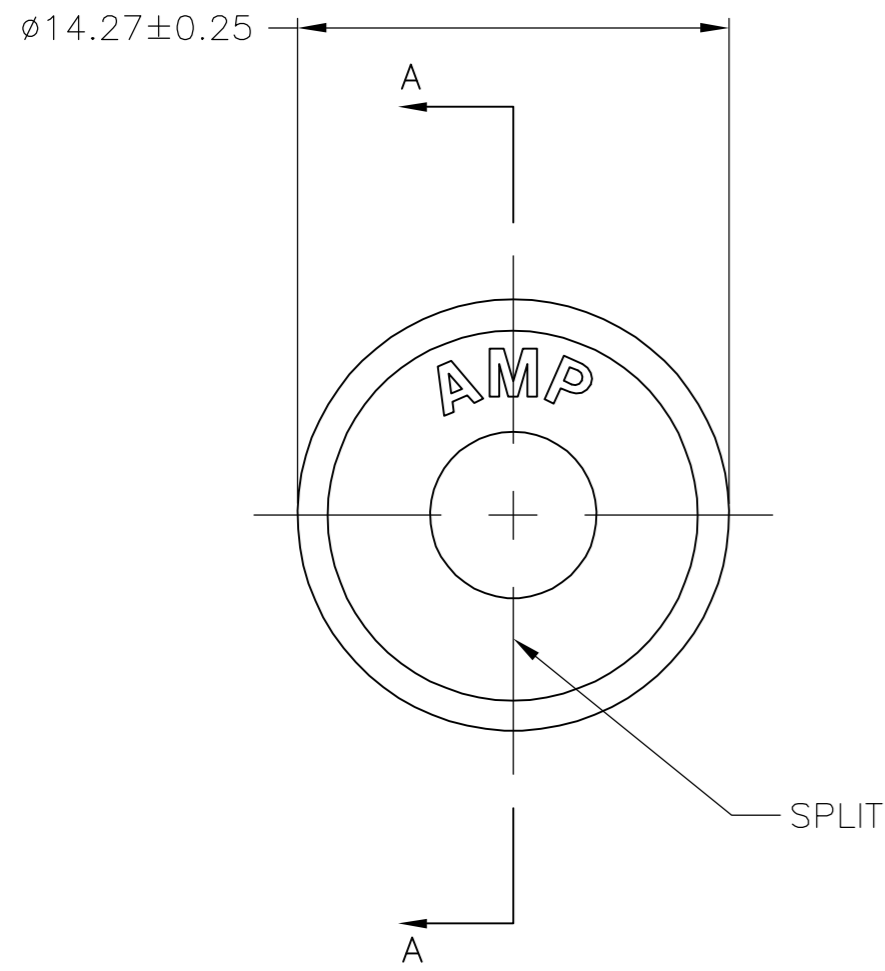
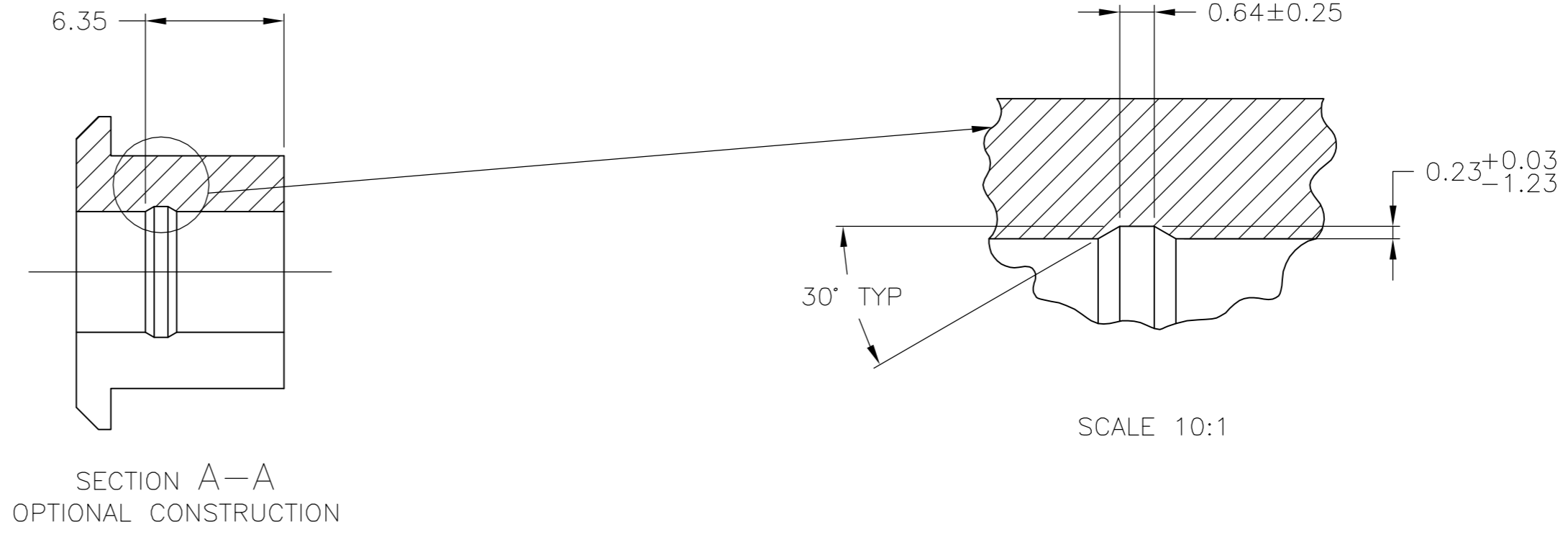
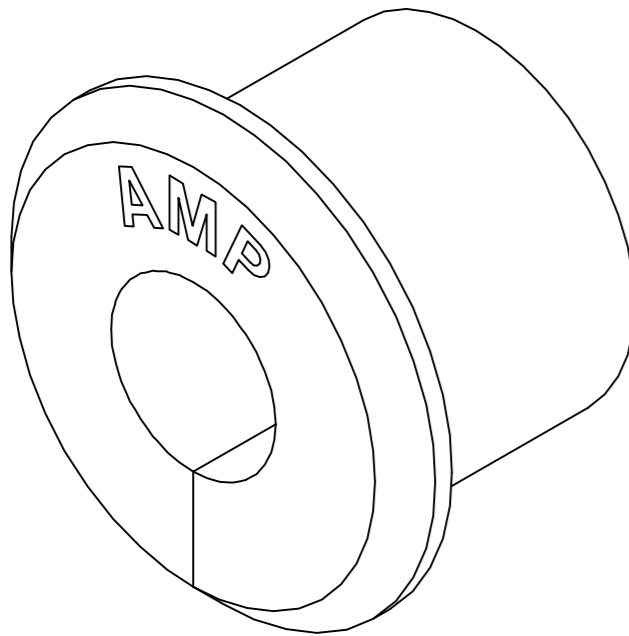

3-DIMENSIONAL MODEL NTS

SUPERCEDED BY 2-350378-1	3	2-350378-1
	2	1-350378-1
	MATERIAL	PART NUMBER

MM	IN	MM	IN	MM	IN
0.38	.015	6.35	.250	-	-
0.25	.010	5.54	.218	-	-
0.23	.009	1.57	.062	14.27	.562
0.13	.005	1.02	.040	10.67	.420
0.03	.001	0.64	.025	9.53	.375

CONVERSION TABLE

METRIC

THIS DRAWING IS A CONTROLLED DOCUMENT.		DWN K. WHITAKER 24MAR06	tyco Electronics Tyco Electronics Corporation Harrisburg, Pa 17105-3608	
DIMENSIONS: mm		CHK C. JONES 24MAR06	NAME GROMMET,SPLIT,M.R.	
TOLERANCES UNLESS OTHERWISE SPECIFIED: 0 PLC ± - 1 PLC ± - 2 PLC ± - 3 PLC ± 0.13 4 PLC ± - ± 1'0"		APVD C. JONES 24MAR06	PRODUCT SPEC -	
MATERIAL SEE TABLE		FINISH -	APPLICATION SPEC -	RESTRICTED TO -
CUSTOMER DRAWING		WEIGHT -	SIZE A2	CAGE CODE 00779
		SCALE 4:1	DRAWING NO C=350378	SHEET 1 OF 1
			REV H	

350378