

HC49USM Series



Product Feature:

Low Cost SMD Package
Low ESR
Compatible with Leadfree Processing

Applications:

Fibre Channel
Server & Storage
Sonet /SDH
802.11 / Wifi
T1/E1.T3/E3
System Clock

Frequency	3.2 MHz to 100 MHz
ESR (Equivalent Series Resistance)	
3.2 MHz - 3.49 MHz	300 Ω Max.
3.5 MHz - 3.99 MHz	200 Ω Max.
4.0 MHz - 4.99 MHz	150 Ω Max.
5.0 MHz - 5.99 MHz	120 Ω Max.
6.0 MHz - 6.99 MHz	100 Ω Max.
7.0 MHz - 8.9 MHz	80 Ω Max.
9.0 MHz - 12.9 MHz	60 Ω Max.
13 MHz - 19.9 MHz	40 Ω Max.
20 MHz - 36 MHz	30 Ω Max.
36 MHz - 100.0 MHz (3rd O.T.)	100 Ω Max.
Shunt Capacitance (C0)	7 pF Max.
Frequency Tolerance @ 25° C	±30 ppm Standard (see Part Number Guide for more options)
Frequency Stability over Temperature	±50 ppm Standard (see Part Number Guide for more options)
Crystal Cut	AT Cut
Load Capacitance	18 pF Standard (see Part Number Guide for more options)
Drive Level	1 mW Max.
Aging	±5 ppm Max. / Year Standard
Temperature	
Operating	0° C to +70° C Standard (see Part Number Guide for more options)
Storage	-40° C to +85° C Standard

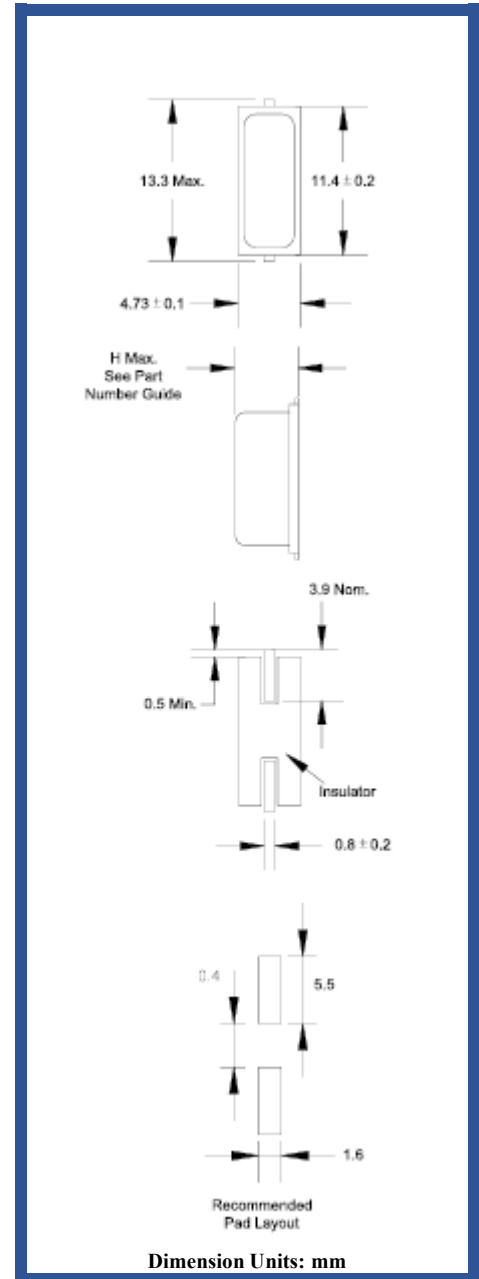

Part Number Guide		Sample Part Number: HC49USM - FB1F18 - 20.000 MHz				
Package	Tolerance (ppm) at Room Temperature	Stability (ppm) over Operating Temperature	Operating Temperature Range	Mode (overtone)	Load Capacitance (pF)	Frequency (MHz)
HC49USM- (4.5 mm H)	B = ±50ppm F = ±30ppm	A = ±100ppm	0 = 0°C to +50°C	F = Fundamental	18pF Standard Or Specify	-20.000 MHz
		B = ±50ppm	1 = 0°C to +70°C	3 = Third Overtone		
HC49USM2- (3.5 mm H)	G = ±25ppm H = ±20ppm	G = ±25ppm	2 = -10°C to +60°C			
		H = ±20ppm	3 = -20°C to +70°C			
HC49USM3- (3.1 mm H)	I = ±15ppm J = ±10ppm*	I = ±15ppm	5 = -40°C to +85°C			
		J = ±10ppm*	9 = -10°C to +50°C			

* Not available at all frequencies. ** Not available for all temperature ranges.

Pb Free Solder Reflow Profile:

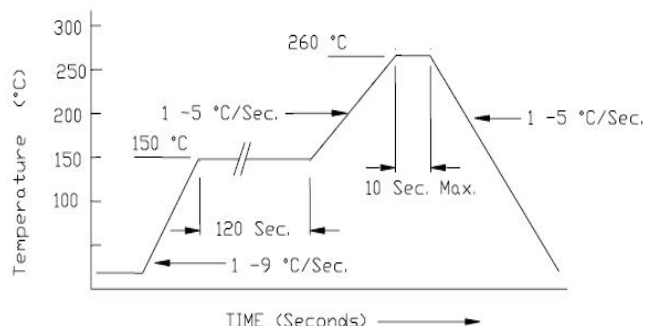

Typical Circuit:

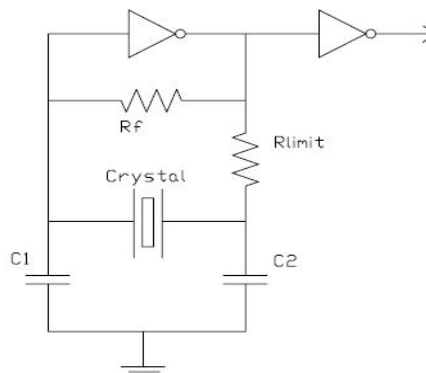

*Units are backward compatible with 240C reflow processes

Package Information:

MSL = N/A

Termination = e4 (Sn / Cu/ Ag over Ni over Kovar base metal).

Tape and Reel Information:

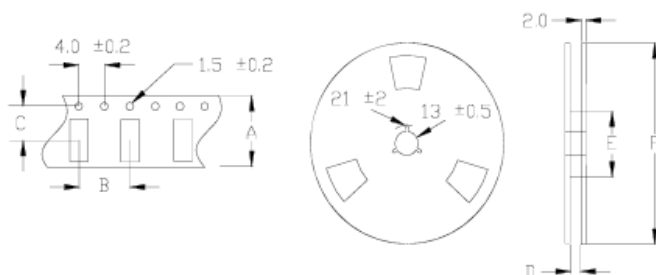

A	24 +/- 0.3
B	12 +/- 0.2
C	11.5 +/- 0.2
D	25 +/- 1.5
E	80/100
F	330
QTY per Reel	1000

Environmental Specifications:

Thermal Shock	MIL-STD-883, Method 1011, Condition A
Moisture Resistance	MIL-STD-883, Method 1004
Mechanical Shock	MIL-STD-883, Method 2002, Condition B
Mechanical Vibration	MIL-STD-883, Method 2007, Condition A
Resistance to Soldering Heat	J-STD-020C, Table 5-2 Pb-free devices (except 2 cycles max)
Hazardous Substance	Pb-Free / RoHS / Green Compliant
Solderability	JESD22-B102-D Method 2 (Preconditioning E)
Terminal Strength	MIL-STD-883, Method 2004, Test Condition D
Gross Leak	MIL-STD-883, Method 1014, Condition C
Fine Leak	MIL-STD-883, Method 1014, Condition A2, R1=2x10 ⁻⁸ atm cc/s
Solvent Resistance	MIL-STD-202, Method 215