

REVISIONS			
REV	DESCRIPTION	DATE	APPROVED
A	INITIAL RELEASE	03/03/09	A.D.M.

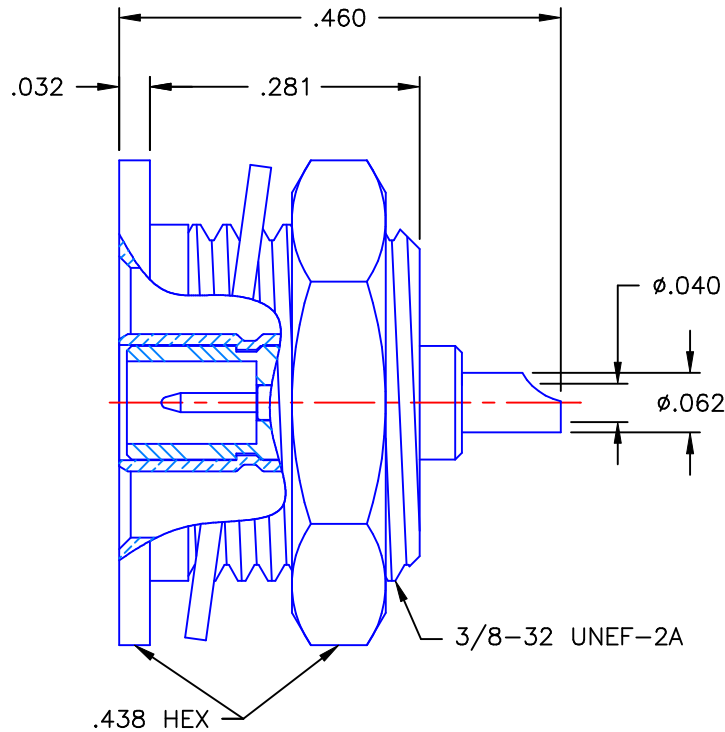

NOTES:



MATERIALS:

1. INSULATOR = VIRGIN WHITE TEFLON PER ASTM D1710, GRADE 1, TYPE I, CLASS "B".
2. LOCWASHER = PHOSPHOR BRONZE PER ASTM B139, COPPER ALLOY C53400, TEMPER H04.
3. ALL OTHER METAL PARTS = BRASS PER ASTM B16, ALLOY C36000, TEMPER H02.

FINISHES:

1. CONTACT = GOLD PLATE PER MIL-G-45204, TYPE II, CLASS 1, GRADE C, OVER .00010 TO .00020 STRESS FREE SULFAMATE NICKEL PER QQ-N-290.
2. ALL OTHER METAL PARTS = GOLD PLATE PER MIL-G-45204, TYPE II, CLASS 0, GRADE C, OVER .00010 TO .00020 COPPER STRIKE PER MIL-C-14550.

Property of Radiall Incorporated  
 This document cannot be reproduced or  
 communicated to a third party without prior  
 written permission of RADIALL Incorporated.

UNLESS OTHERWISE SPECIFIED DIMENSIONS ARE IN INCHES TOLERANCES ON	DWN: A.D.M.	DATE 03/03/09	 <b>APPLIED ENGINEERING PRODUCTS</b> 104 John W. Murphy Dr. New Haven, CT 06513
	CHKD: D.N.	DATE 03/03/09	
DECIMAL	ANGLE	APVD: J.M.	DATE 03/03/09
REFERENCE:		MATERIALS & FINISHES:  SEE NOTES	
ORIGINATOR: A.D.M. DATE: 03/03/09		SIZE A	FSCM NO. 19505
		DWG NO. 2014-1511-000	
		SCALE 5:1	THIRD ANGLE PROJECTION 
		REV A	
		SHEET 1 OF 1	

2014-1511-000