

Description

The AH1898 is a micropower magnetic range selectable (Bop/Brp) Omnipolar Hall effect switch IC with internal pull up and pull down capability, designed for portable and battery powered consumer equipment such as cellular phones and portable PCs. To support battery powered equipment and low voltage microcontrollers, the AH1898 can operate over the supply range of 1.6V to 3.6V and uses a hibernating clocking system to minimize the power consumption. The average supply current is only 4.3µA typical at 1.80V. The AH1898 has an 8kV ESD rating on the supply and output pins. To minimize PCB space, the AH1898 is packaged in the small CSP package (0.81mm x 0.81mm typical).

The output is activated with either a north or south pole of sufficient magnetic field strength. The user can select one of two magnetic sensitivity bands via the BSEL pin without the addition of any external components allowing a flexible but small solution. The band select pin can be hardwired or be changed on the fly via a logic source such as a micro-controller. When the magnetic flux density (**B**) perpendicular to the package is larger than operate point (**Bop**), the output will be turned on (pulled low) and held until **B** is lower than release point (**Brp**). The output will remain off when there is no magnetic field.

Pin Assignments

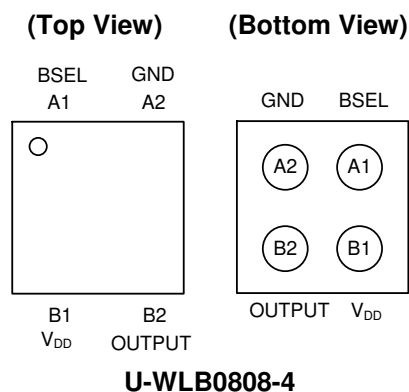

Features

- Omnipolar Operation (North or South Pole)
- Programmable Operate and Release Points
- Supply Voltage of 1.6V to 3.6V
- Micropower Operation
- Chopper Stabilized Design Provides:
 - Superior Temperature Stability
 - Minimal Switch Point Drift
 - Enhanced Immunity to Physical Stress
- No External Pull-Up Resistors Required
- Good RF Noise Immunity
- -40°C to +85°C Operating Temperature
- 8kV Human Body Model ESD Capability
- Miniature U-WLB0808-4 (CSP 0.81mm x 0.81mm Typical)
- **Totally Lead-Free & Fully RoHS Compliant (Notes 1 & 2)**
- **Halogen and Antimony Free. "Green" Device (Note 3)**
- **For automotive applications requiring specific change control (i.e. parts qualified to AEC-Q100/101/200, PPAP capable, and manufactured in IATF 16949 certified facilities), please [contact us](mailto:contact@diodes.com) or your local Diodes representative.**
<https://www.diodes.com/quality/product-definitions/>

Applications

- Open and Close Detect for Cellular Phones
- Holster or Cover Detect for Cellular Phones and Tablet PCs
- Cover or Display Switch in Portable PCs
- Digital Still, Video Cameras and Handheld Gaming Consoles
- Proximity and Position Switches

Notes:

1. No purposely added lead. Fully EU Directive 2002/95/EC (RoHS), 2011/65/EU (RoHS 2) & 2015/863/EU (RoHS 3) compliant.
2. See <https://www.diodes.com/quality/lead-free/> for more information about Diodes Incorporated's definitions of Halogen- and Antimony-free, "Green" and Lead-free.
3. Halogen- and Antimony-free "Green" products are defined as those which contain <900ppm bromine, <900ppm chlorine (<1500ppm total Br + Cl) and <1000ppm antimony compounds.

Typical Applications Circuit

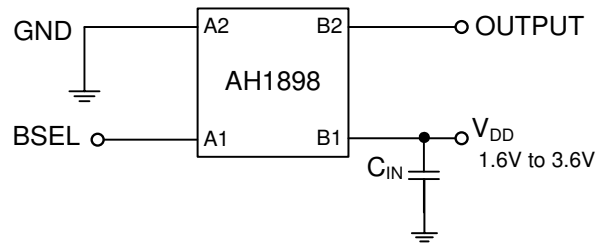

Note: 4. C_{IN} is for power stabilization and to strengthen the noise immunity, the recommended capacitance is 100nF typical.

Pin Descriptions

Package: U-WLB0808-4

Pin Number	Pin Name	Function
A1	BSEL	Band Select Pin to Select Operating and Release Gauss Points
A2	GND	Ground Pin
B1	V _{DD}	Power Supply Input
B2	OUTPUT	Output Pin

Functional Block Diagram

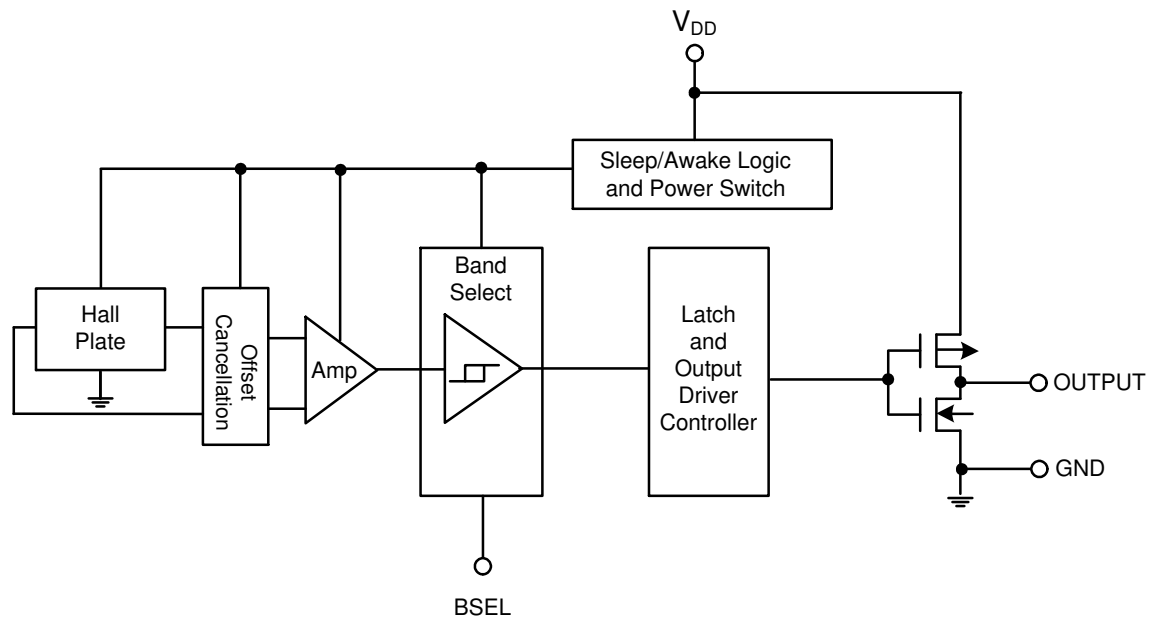

Absolute Maximum Ratings (Note 5) (@T_A = +25°C, unless otherwise specified.)

Symbol	Parameter	Rating	Unit
V _{DD}	Supply Voltage (Note 6)	6	V
V _{DD_REV}	Reverse Supply Voltage	-0.3	V
I _{OUTPUT}	Output Current (Source and Sink)	2.5	mA
B	Magnetic Flux Density	Unlimited	
P _D	Package Power Dissipation	U-WLB0808-4	160 mW
T _S	Storage Temperature Range	-65 to +150	°C
T _J	Maximum Junction Temperature	150	°C
ESD HBM	Human Body Model (HBM) ESD Capability	V _{DD} , GND and OUT Pins	8 kV
		BSEL Pin	6 kV

- Notes:
- Stresses greater than the 'Absolute Maximum Ratings' specified above can cause permanent damage to the device. These are stress ratings only; functional operation of the device at these or any other conditions exceeding those indicated in this specification is not implied. Device reliability may be affected by exposure to absolute maximum rating conditions for extended periods of time.
 - The absolute maximum V_{DD} of 6V is a transient stress rating and is not meant as a functional operating condition. It is not recommended to operate the device at the absolute maximum rated conditions for any period of time.

Recommended Operating Conditions (@T_A = +25°C, unless otherwise specified.)

Symbol	Parameter	Conditions	Rating	Unit
V _{DD}	Supply Voltage	Operating	1.6 to 3.6	V
T _A	Operating Temperature Range	Operating	-40 to +85	°C

Electrical Characteristics (@T_A = +25°C, V_{DD} = 1.8V, unless otherwise specified.)

Symbol	Parameter	Conditions	Min	Typ	Max	Unit
V _{OL}	Output Low Voltage (ON)	I _{OUT} = 1mA	—	0.1	0.2	V
V _{OH}	Output High Voltage (OFF)	I _{OUT} = -1mA	V _{DD} - 0.2	V _{DD} - 0.1	—	V
V _{SEL_LB}	Band Select Voltage for Low Band	—	0	—	0.5	V
V _{SEL_HB}	Band Select Voltage for High Band	—	1.4	—	3.6	V
R _{PU_BSEL}	BSEL Pin Internal Pull-Up Resistor	(Note 7)	—	50	—	kΩ
I _{DD(awake)}	Supply Current	During 'Awake' Period	—	2.1	—	mA
I _{DD(sleep)}		During 'Sleep' Period	—	2.5	—	μA
I _{DD(avg)}	Average Supply Current	V _{DD} = 1.8V	—	4.3	8	μA
		V _{DD} = 3.6V	—	7.2	13	μA
t _{awake}	Awake Time	(Note 8)	—	50	100	μs
t _{period}	Period	(Note 8)	—	50	100	ms
D.C.	Duty Cycle	—	—	0.1	—	%
t _{BAND}	Band Transition Time	(Note 9)	—	100.0	200.1	ms

- Notes:
- BSEL pin internal pull-up resistor is only active during AWAKE time.
 - When power is initially turned on, the operating V_{DD} (1.6V to 3.6V) must be applied to guarantee the output sampling. The output state is valid after the second operating phase (typical 100ms).
 - Transition time varies dependent on the timing of BSEL activation during the sleep and awake phases.

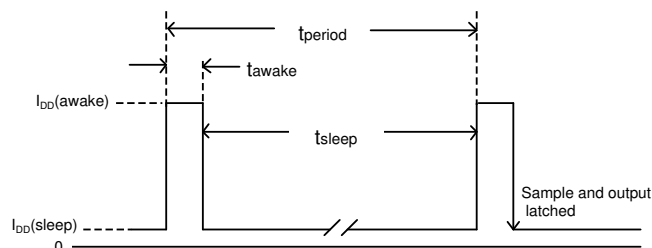

Magnetic Characteristics (Note 10 & 11) ($T_A = +25^\circ\text{C}$, $V_{DD} = 1.6\text{V}$ to 3.6V , unless otherwise specified.)

(1mT = 10 Gauss)

BSEL	Symbol	Characteristics	Min	Typ	Max	Unit
Low	Bops _{LB} (South Pole to Part Marking Side)	Low Band - Operation Point	18	35	55	Gauss
Low	Bopn _{LB} (North Pole to Part Marking Side)		-55	-35	-18	
Low	Brps _{LB} (South Pole to Part Marking Side)	Low Band - Release Point	12	25	45	
Low	Brpn _{LB} (North Pole to Part Marking Side)		-45	-25	-12	
High	Bops _{HB} (South Pole to Part Marking Side)	High Band - Operation Point	43	60	80	
High	Bopn _{HB} (North Pole to Part Marking Side)		-80	-60	-43	
High	Brps _{HB} (South Pole to Part Marking Side)	High Band - Release Point	35	50	70	
High	Brpn _{HB} (North Pole to Part Marking Side)		-70	-50	-35	
—	Bhy ($ B_{opx} - B_{rpx} $)	Hysteresis	—	10	—	

Notes: 10. Typical data is at $T_A = +25^\circ\text{C}$, $V_{DD} = 1.8\text{V}$.
11. Magnetic characteristics may vary with operating temperature and after soldering.

The AH1898 includes a band select pin (BSEL) so that the operate (Bops and Bopn) and release (Brps and Brpn) points can be adjusted between two pre-defined ranges. The BSEL can be hard wired within the application circuit or the band can be selected on the fly by using the BSEL pin as a logic input. This feature allows the AH1898 sensitivity to be changed by firmware within the application without the addition of any external components. If the BSEL pin is left open circuit the AH1898 defaults to high band.

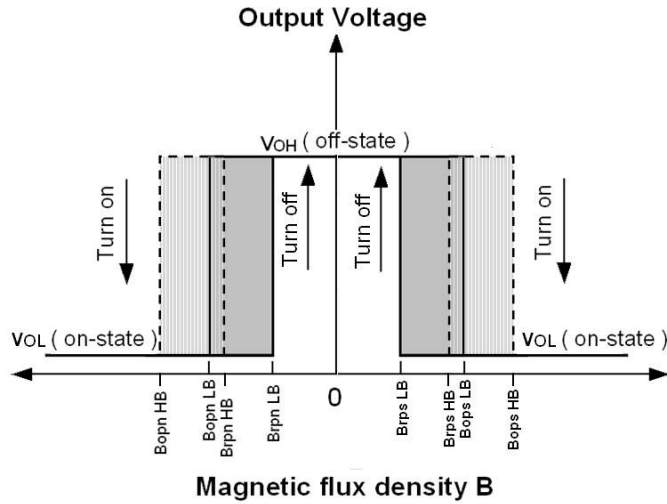

Application Note

Applications Circuit One – Low Band

Connecting the BSEL pin to ground permanently configures the AH1898 into its high sensitivity mode, requiring a reduced magnetic flux density to activate its output (Low Band).

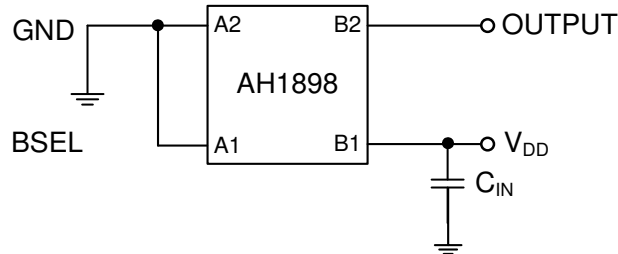

Applications Circuit Two – High Band

Connecting the BSEL pin to VDD or to a voltage greater than 1.4V or leaving the BSEL pin unconnected configures the AH1898 into its low sensitivity mode, requiring a higher magnetic flux density to activate its output (High Band).

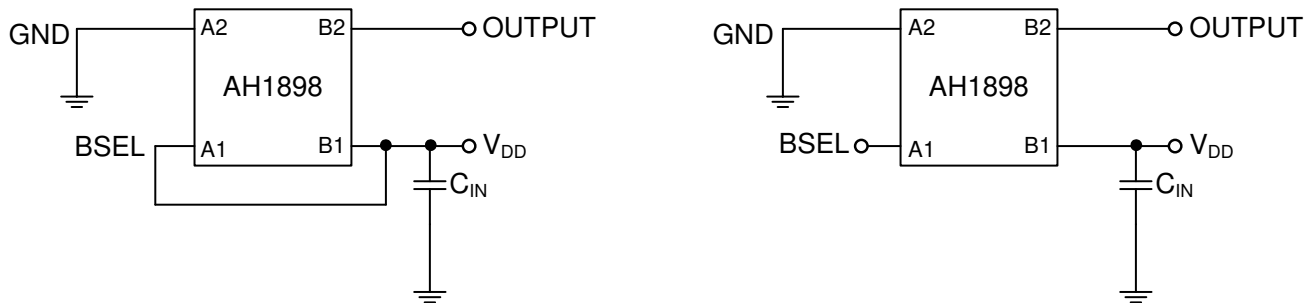

Applications Circuit Three – Adjustable Sensitivity

To enhance flexibility within the application, the sensitivity can be adjusted with a standard logic signal allowing it to be controlled by a micro-controller or a logic source. This allows the sensitivity to be changed within the application without a hardware change. Whenever the sensitivity band selection is changed, the band selection changeover should be allowed to complete for the output to be valid.

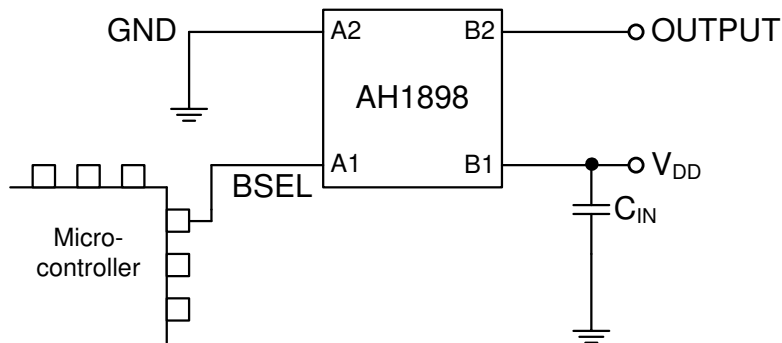

Application Note (continued)

Bands Select Change Timing and Valid Output

Whenever band selection BSEL pin input is changed, allow for band selection changeover to complete and stabilize. The output is valid only after the second complete operating 'awake' phase. Time taken for the output to be valid, after the BSEL change, depends on timing of BSEL change during the sleep and awake phase; this transition time (t_{BAND}) can range from 100ms typical and 200.1ms maximum.

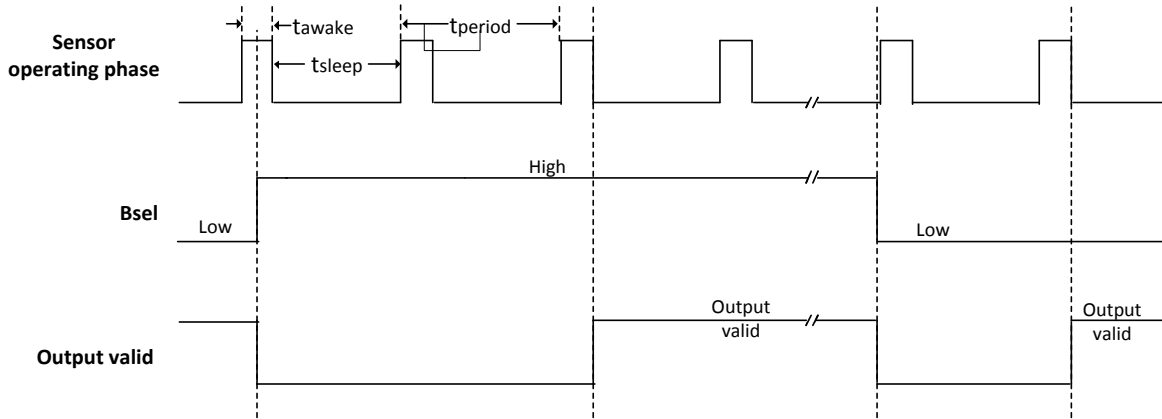

Typical Operating Characteristics

Typical switch points characteristics in low band (BSEL = Low) and high band (BSEL = High)

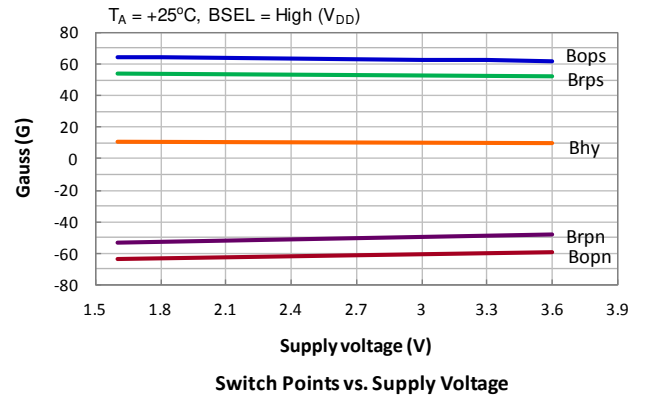
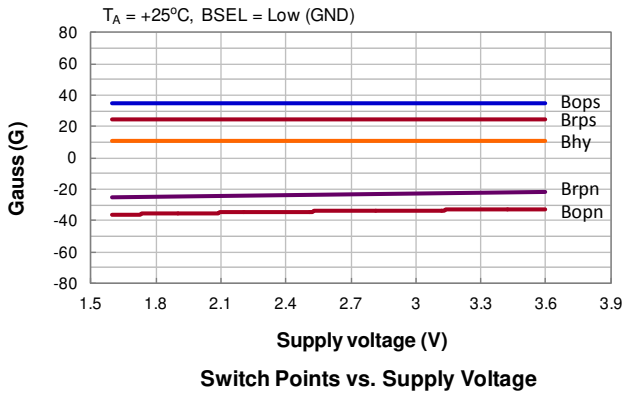
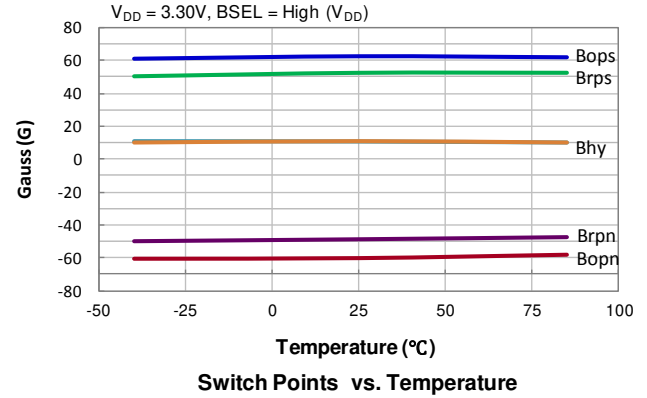
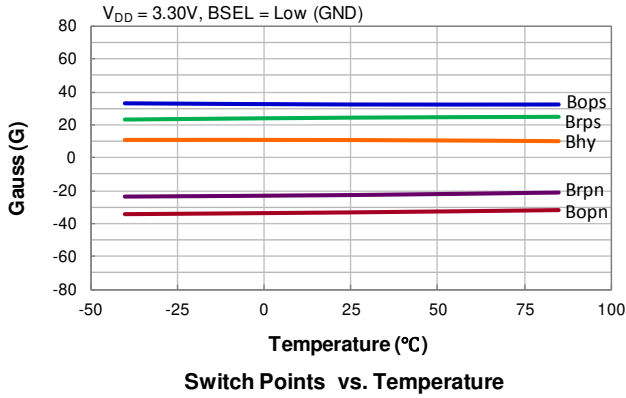
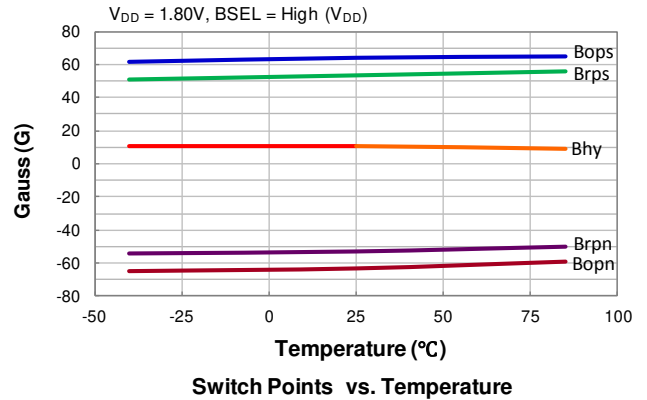
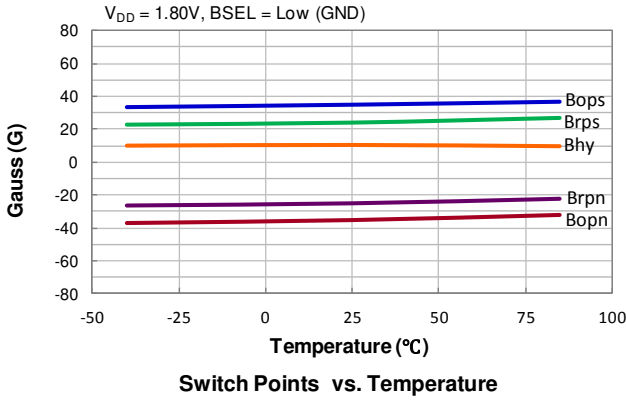

Typical Operating Characteristics (continued)

Average Supply Current I_{DD}(avg)

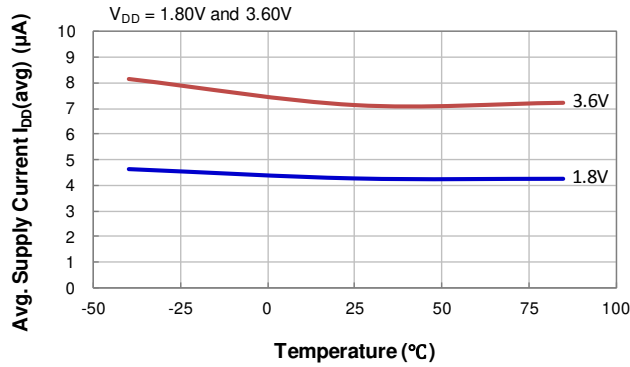

Average Supply Current vs. Temperature

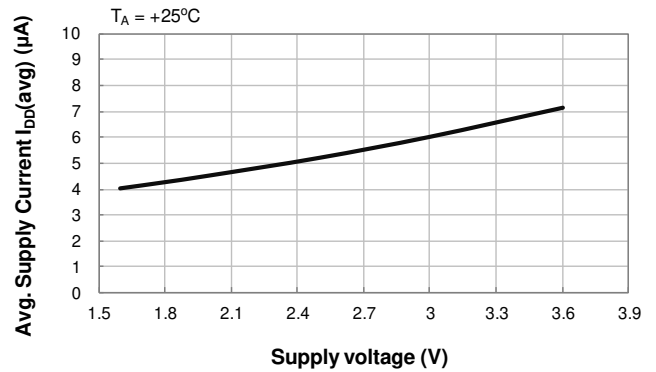

Average Supply Current vs. Supply Voltage

Ordering Information

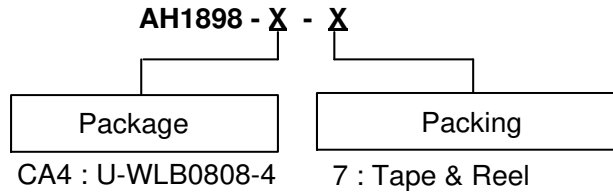

Part Number	Package Code	Packaging	7" Tape and Reel	
			Quantity	Part Number Suffix
AH1898-CA4-7	CA4	U-WLB0808-4	3,000/Tape & Reel	-7

Marking Information

(1) Package Type: U-WLB0808-4

(Top View)

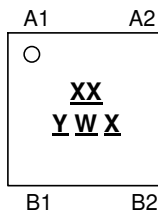

- XX : Identification Code
- Y : Year : 0 to 9
- W : Week : A to Z : 1 to 26 Week;
a to z : 27 to 52 Week; z Represents
52 and 53 Week
- X : Internal Code

Part Number	Package	Identification Code
AH1898-CA4-7	U-WLB0808-4	B8

Package Outline Dimensions

Please see <http://www.diodes.com/package-outlines.html> for the latest version.

(1) Package Type: U-WLB0808-4

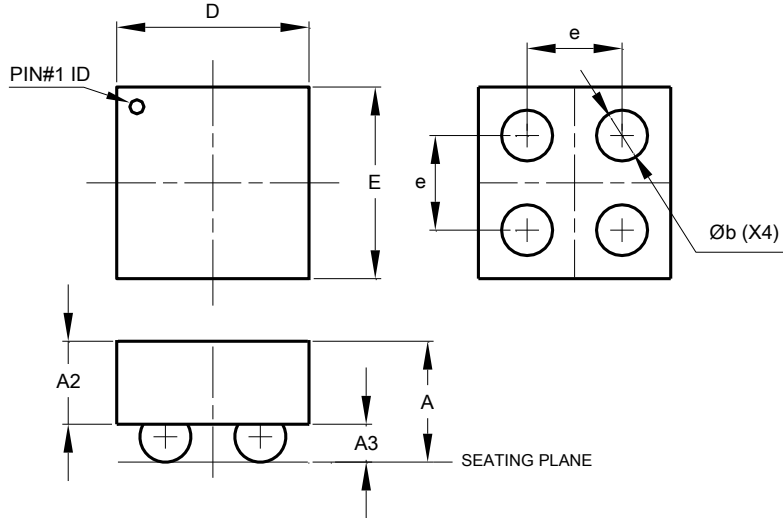

U-WLB0808-4			
Dim	Min	Max	Typ
A	0.511 REF		
A2	0.336	0.366	0.351
A3	0.15	0.17	0.16
b	0.205	0.225	0.215
D	0.795	0.825	0.81
E	0.795	0.825	0.81
e	-	-	0.40
All Dimensions in mm			

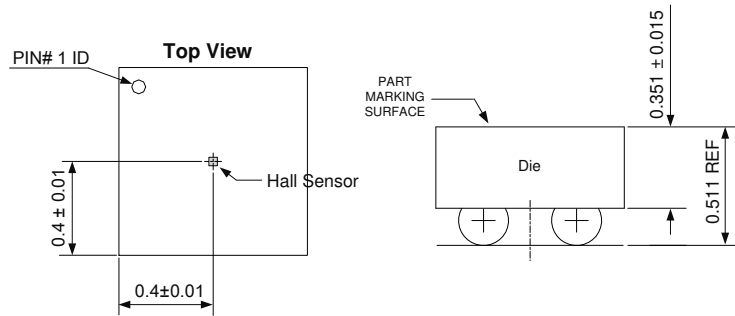

Sensor Location

Suggested Pad Layout

Please see <http://www.diodes.com/package-outlines.html> for the latest version.

(1) Package Type: U-WLB0808-4

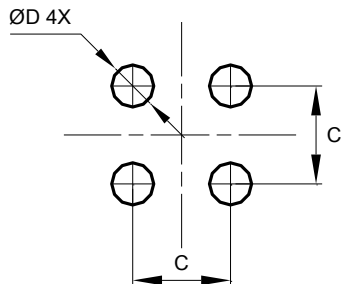

U-WLB0808-4	
Dimensions	Value
C	0.40
D	0.172
All Dimensions in mm	

Taping Orientation

Package Type: U-WLB0808-4

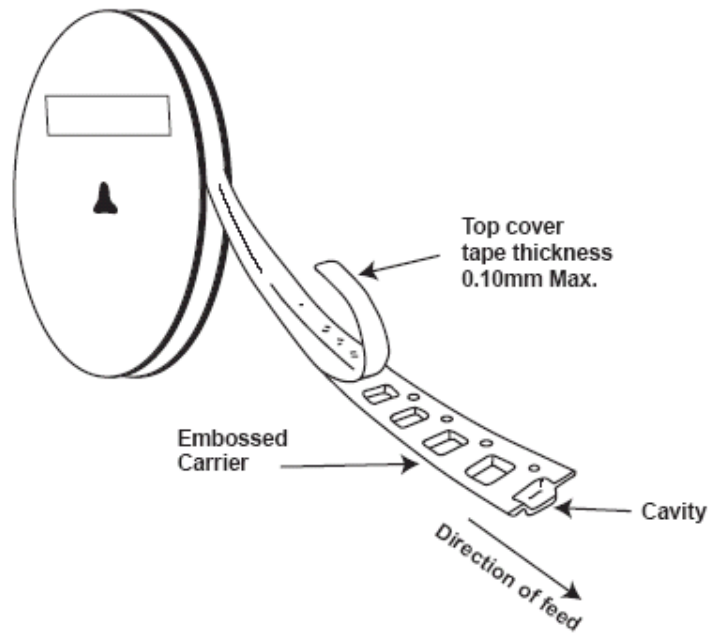
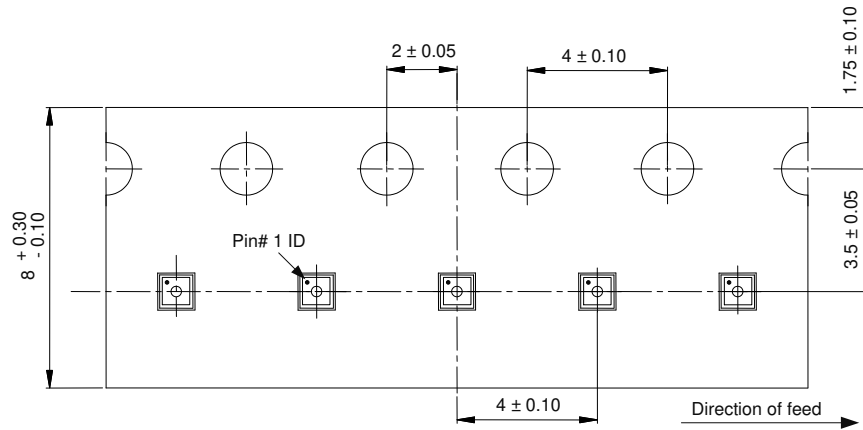

Mechanical Data

- Moisture Sensitivity: Level 1 per J-STD-020
- Terminals: Symbol Used to Identify a Tin/Silver/Copper (SnAgCu) Terminal Finish/Ball with A Silver Content >1.5% and No Other Intentionally Added Elements (e1)
- Weight: 0.001 grams (Approximate)

IMPORTANT NOTICE

1. DIODES INCORPORATED AND ITS SUBSIDIARIES ("DIODES") MAKE NO WARRANTY OF ANY KIND, EXPRESS OR IMPLIED, WITH REGARDS TO ANY INFORMATION CONTAINED IN THIS DOCUMENT, INCLUDING, BUT NOT LIMITED TO, THE IMPLIED WARRANTIES OF MERCHANTABILITY, FITNESS FOR A PARTICULAR PURPOSE OR NON-INFRINGEMENT OF THIRD PARTY INTELLECTUAL PROPERTY RIGHTS (AND THEIR EQUIVALENTS UNDER THE LAWS OF ANY JURISDICTION).
2. The Information contained herein is for informational purpose only and is provided only to illustrate the operation of Diodes products described herein and application examples. Diodes does not assume any liability arising out of the application or use of this document or any product described herein. This document is intended for skilled and technically trained engineering customers and users who design with Diodes products. Diodes products may be used to facilitate safety-related applications; however, in all instances customers and users are responsible for (a) selecting the appropriate Diodes products for their applications, (b) evaluating the suitability of the Diodes products for their intended applications, (c) ensuring their applications, which incorporate Diodes products, comply the applicable legal and regulatory requirements as well as safety and functional-safety related standards, and (d) ensuring they design with appropriate safeguards (including testing, validation, quality control techniques, redundancy, malfunction prevention, and appropriate treatment for aging degradation) to minimize the risks associated with their applications.
3. Diodes assumes no liability for any application-related information, support, assistance or feedback that may be provided by Diodes from time to time. Any customer or user of this document or products described herein will assume all risks and liabilities associated with such use, and will hold Diodes and all companies whose products are represented herein or on Diodes' websites, harmless against all damages and liabilities.
4. Products described herein may be covered by one or more United States, international or foreign patents and pending patent applications. Product names and markings noted herein may also be covered by one or more United States, international or foreign trademarks and trademark applications. Diodes does not convey any license under any of its intellectual property rights or the rights of any third parties (including third parties whose products and services may be described in this document or on Diodes' website) under this document.
5. Diodes products are provided subject to Diodes' Standard Terms and Conditions of Sale (<https://www.diodes.com/about/company/terms-and-conditions/terms-and-conditions-of-sales/>) or other applicable terms. This document does not alter or expand the applicable warranties provided by Diodes. Diodes does not warrant or accept any liability whatsoever in respect of any products purchased through unauthorized sales channel.
6. Diodes products and technology may not be used for or incorporated into any products or systems whose manufacture, use or sale is prohibited under any applicable laws and regulations. Should customers or users use Diodes products in contravention of any applicable laws or regulations, or for any unintended or unauthorized application, customers and users will (a) be solely responsible for any damages, losses or penalties arising in connection therewith or as a result thereof, and (b) indemnify and hold Diodes and its representatives and agents harmless against any and all claims, damages, expenses, and attorney fees arising out of, directly or indirectly, any claim relating to any noncompliance with the applicable laws and regulations, as well as any unintended or unauthorized application.
7. While efforts have been made to ensure the information contained in this document is accurate, complete and current, it may contain technical inaccuracies, omissions and typographical errors. Diodes does not warrant that information contained in this document is error-free and Diodes is under no obligation to update or otherwise correct this information. Notwithstanding the foregoing, Diodes reserves the right to make modifications, enhancements, improvements, corrections or other changes without further notice to this document and any product described herein. This document is written in English but may be translated into multiple languages for reference. Only the English version of this document is the final and determinative format released by Diodes.
8. Any unauthorized copying, modification, distribution, transmission, display or other use of this document (or any portion hereof) is prohibited. Diodes assumes no responsibility for any losses incurred by the customers or users or any third parties arising from any such unauthorized use.

Copyright © 2021 Diodes Incorporated

www.diodes.com