

---

# High Performance 8-bit Microcontrollers

---

## 1. Description

Atmel Wireless & Microcontrollers TS80C51Rx2 is high performance CMOS ROM, OTP, EPROM and ROMless versions of the 80C51 CMOS single chip 8-bit microcontroller.

The TS80C51Rx2 retains all features of the 80C51 with extended ROM/EPROM capacity (16/32/64 Kbytes), 256 bytes of internal RAM, a 7-source, 4-level interrupt system, an on-chip oscillator and three timer/counters.

In addition, the TS80C51Rx2 has a Programmable Counter Array, an XRAM of 256 or 768 bytes, a Hardware Watchdog Timer, a more versatile serial channel that facilitates multiprocessor communication (EUART) and a X2 speed improvement mechanism.

The fully static design of the TS80C51Rx2 allows to reduce system power consumption by bringing the clock frequency down to any value, even DC, without loss of data.

The TS80C51Rx2 has 2 software-selectable modes of reduced activity for further reduction in power consumption. In the idle mode the CPU is frozen while the timers, the serial port and the interrupt system are still operating. In the power-down mode the RAM is saved and all other functions are inoperative.

## 2. Features

- 80C52 Compatible
  - 8051 pin and instruction compatible
  - Four 8-bit I/O ports
  - Three 16-bit timer/counters
  - 256 bytes scratchpad RAM
- High-Speed Architecture
  - 40 MHz @ 5V, 30MHz @ 3V
  - X2 Speed Improvement capability (6 clocks/machine cycle)  
30 MHz @ 5V, 20 MHz @ 3V (Equivalent to 60 MHz @ 5V, 40 MHz @ 3V)
- Dual Data Pointer
- On-chip ROM/EPROM (16K-bytes, 32K-bytes, 64K-bytes)
- On-chip eXpanded RAM (XRAM) (256 or 768 bytes)
- Programmable Clock Out and Up/Down Timer/Counter 2
- Programmable Counter Array with
  - High Speed Output,
  - Compare / Capture,
  - Pulse Width Modulator,
  - Watchdog Timer Capabilities
- Hardware Watchdog Timer (One-time enabled with Reset-Out)
- 2 extra 8-bit I/O ports available on RD2 with high pin count packages
- Asynchronous port reset
- Interrupt Structure with
  - 7 Interrupt sources,
  - 4 level priority interrupt system
- Full duplex Enhanced UART
  - Framing error detection
  - Automatic address recognition
- Low EMI (inhibit ALE)
- Power Control modes
  - Idle mode
  - Power-down mode
  - Power-off Flag
- Once mode (On-chip Emulation)
- Power supply: 4.5-5V, 2.7-5.5V
- Temperature ranges: Commercial (0 to 70°C) and Industrial (-40 to 85°C)
- Packages: PDIL40, PLCC44, VQFP44 1.4, CQJP44 (window), CDIL40 (window), PLCC68, VQFP64 1.4, JLCC68 (window)

PDIL40 PLCC44 VQFP44 1.4	ROM (bytes)	EPROM (bytes)	XRAM (bytes)	TOTAL RAM (bytes)	I/O
TS80C51RA2	0	0	256	512	32
TS80C51RD2	0	0	768	1024	32
TS83C51RB2	16k	0	256	512	32
TS83C51RC2	32k	0	256	512	32
TS83C51RD2	64k	0	768	1024	32
TS87C51RB2	0	16k	256	512	32
TS87C51RC2	0	32k	256	512	32
TS87C51RD2	0	64k	768	1024	32

PLCC68 VQFP64 1.4	ROM (bytes)	EPROM (bytes)	XRAM (bytes)	TOTAL RAM (bytes)	I/O
TS80C51RD2	0	0	768	1024	48
TS83C51RD2	64k	0	768	1024	48
TS87C51RD2	0	64k	768	1024	48

### 3. Block Diagram

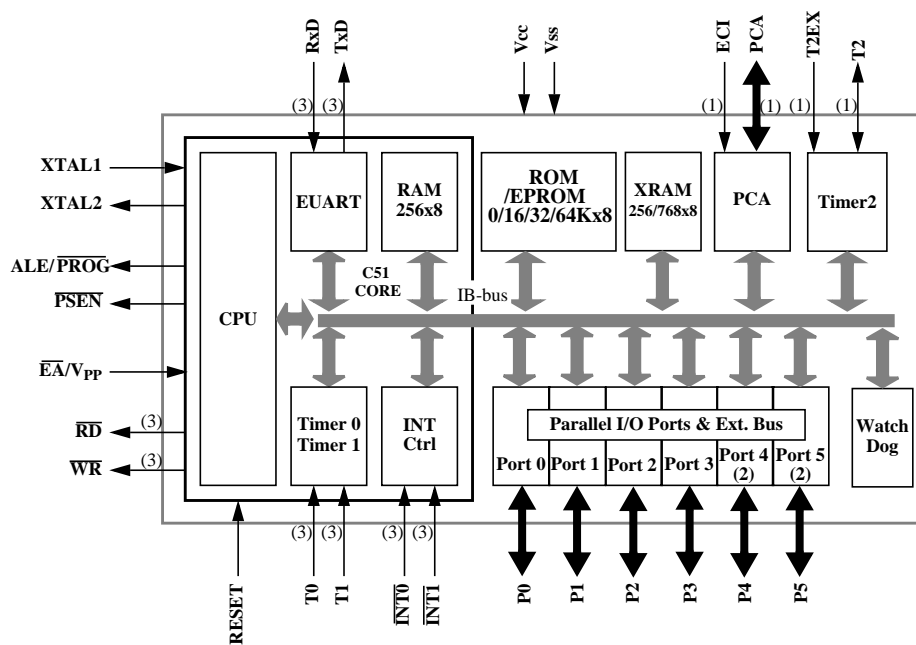

- (1): Alternate function of Port 1
- (2): Only available on high pin count packages
- (3): Alternate function of Port 3

## 4. SFR Mapping

The Special Function Registers (SFRs) of the TS80C51Rx2 fall into the following categories:

- C51 core registers: ACC, B, DPH, DPL, PSW, SP, AUXR1
- I/O port registers: P0, P1, P2, P3, P4, P5
- Timer registers: T2CON, T2MOD, TCON, TH0, TH1, TH2, TMOD, TL0, TL1, TL2, RCAP2L, RCAP2H
- Serial I/O port registers: SADDR, SADEN, SBUF, SCON
- Power and clock control registers: PCON
- HDW Watchdog Timer Reset: WDTRST, WDTPRG
- PCA registers: CL, CH, CCAPiL, CCAPiH, CCON, CMOD, CCAPMi
- Interrupt system registers: IE, IP, IPH
- Others: AUXR, CKCON

**Table 1. All SFRs with their address and their reset value**

	Bit addressable	Non Bit addressable							
	0/8	1/9	2/A	3/B	4/C	5/D	6/E	7/F	
F8h		CH 0000 0000	CCAP0H XXXX XXXX	CCAP1H XXXX XXXX	CCAPL2H XXXX XXXX	CCAPL3H XXXX XXXX	CCAPL4H XXXX XXXX		FFh
F0h	B 0000 0000								F7h
E8h	P5 bit addressable 1111 1111	CL 0000 0000	CCAP0L XXXX XXXX	CCAP1L XXXX XXXX	CCAPL2L XXXX XXXX	CCAPL3L XXXX XXXX	CCAPL4L XXXX XXXX		EFh
E0h	ACC 0000 0000								E7h
D8h	CCON 00X0 0000	CMOD 00XX X000	CCAPM0 X000 0000	CCAPM1 X000 0000	CCAPM2 X000 0000	CCAPM3 X000 0000	CCAPM4 X000 0000		DFh
D0h	PSW 0000 0000								D7h
C8h	T2CON 0000 0000	T2MOD XXXX XX00	RCAP2L 0000 0000	RCAP2H 0000 0000	TL2 0000 0000	TH2 0000 0000			CFh
C0h	P4 bit addressable 1111 1111							P5 byte addressable 1111 1111	C7h
B8h	IP X000 000	SADEN 0000 0000							BFh
B0h	P3 1111 1111							IPH X000 0000	B7h
A8h	IE 0000 0000	SADDR 0000 0000							AFh
A0h	P2 1111 1111		AUXR1 XXXX0XXX0				WDTRST XXXX XXXX	WDTPRG XXXX X000	A7h
98h	SCON 0000 0000	SBUF XXXX XXXX							9Fh
90h	P1 1111 1111								97h
88h	TCON 0000 0000	TMOD 0000 0000	TL0 0000 0000	TL1 0000 0000	TH0 0000 0000	TH1 0000 0000	AUXR XXXXXX00	CKCON XXXX XXX0	8Fh
80h	P0 1111 1111	SP 0000 0111	DPL 0000 0000	DPH 0000 0000				PCON 00X1 0000	87h
	0/8	1/9	2/A	3/B	4/C	5/D	6/E	7/F	

reserved

## 5. Pin Configuration

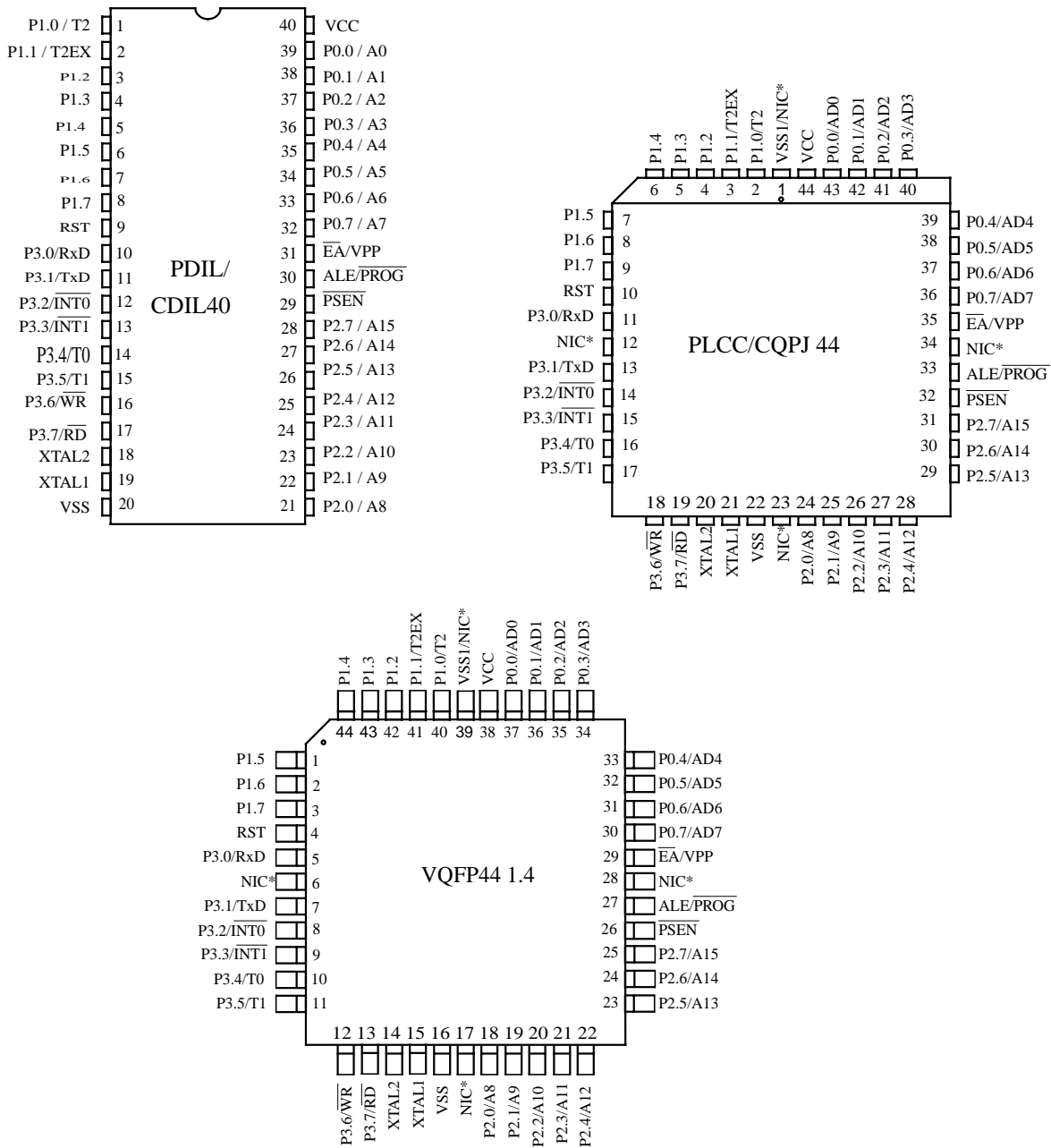

\*NIC: No Internal Connection

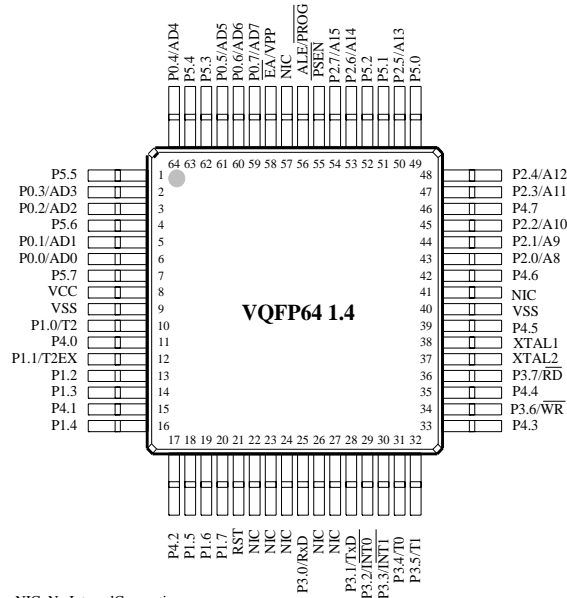
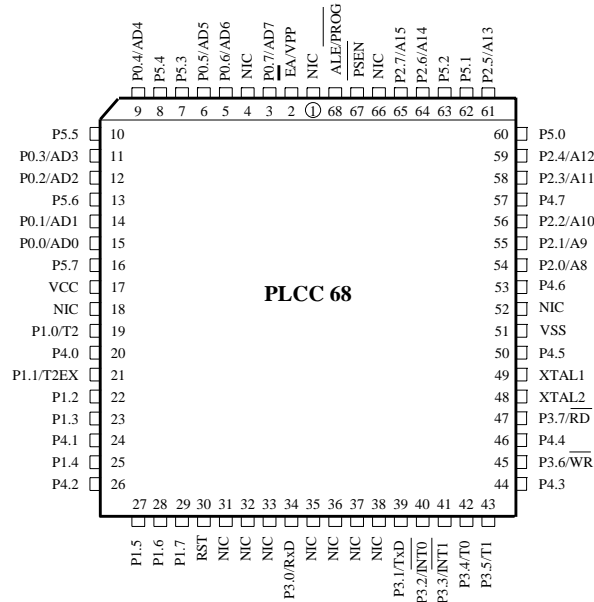

**TS80C51RA2/RD2**  
**TS83C51RB2/RC2/RD2**  
**TS87C51RB2/RC2/RD2**



Mnemonic	Pin Number			Type	Name And Function
	DIL	LCC	VQFP 1.4		
V <sub>SS</sub>	20	22	16	I	<b>Ground:</b> 0V reference
V <sub>SS1</sub>		1	39	I	<b>Optional Ground:</b> Contact the Sales Office for ground connection.
V <sub>CC</sub>	40	44	38	I	<b>Power Supply:</b> This is the power supply voltage for normal, idle and power-down operation
P0.0-P0.7	39-32	43-36	37-30	I/O	<b>Port 0:</b> Port 0 is an open-drain, bidirectional I/O port. Port 0 pins that have 1s written to them float and can be used as high impedance inputs. Port 0 pins must be polarized to V <sub>CC</sub> or V <sub>SS</sub> in order to prevent any parasitic current consumption. Port 0 is also the multiplexed low-order address and data bus during access to external program and data memory. In this application, it uses strong internal pull-up when emitting 1s. Port 0 also inputs the code bytes during EPROM programming. External pull-ups are required during program verification during which P0 outputs the code bytes.
P1.0-P1.7	1-8	2-9	40-44 1-3	I/O	<b>Port 1:</b> Port 1 is an 8-bit bidirectional I/O port with internal pull-ups. Port 1 pins that have 1s written to them are pulled high by the internal pull-ups and can be used as inputs. As inputs, Port 1 pins that are externally pulled low will source current because of the internal pull-ups. Port 1 also receives the low-order address byte during memory programming and verification. Alternate functions for Port 1 include:
	1	2	40	I/O	<b>T2 (P1.0):</b> Timer/Counter 2 external count input/Clockout
	2	3	41	I	<b>T2EX (P1.1):</b> Timer/Counter 2 Reload/Capture/Direction Control
	3	4	42	I	<b>ECI (P1.2):</b> External Clock for the PCA
	4	5	43	I/O	<b>CEX0 (P1.3):</b> Capture/Compare External I/O for PCA module 0
	5	6	44	I/O	<b>CEX1 (P1.4):</b> Capture/Compare External I/O for PCA module 1
	6	7	45	I/O	<b>CEX0 (P1.5):</b> Capture/Compare External I/O for PCA module 2
	7	8	46	I/O	<b>CEX0 (P1.6):</b> Capture/Compare External I/O for PCA module 3
	8	9	47	I/O	<b>CEX0 (P1.7):</b> Capture/Compare External I/O for PCA module 4
P2.0-P2.7	21-28	24-31	18-25	I/O	<b>Port 2:</b> Port 2 is an 8-bit bidirectional I/O port with internal pull-ups. Port 2 pins that have 1s written to them are pulled high by the internal pull-ups and can be used as inputs. As inputs, Port 2 pins that are externally pulled low will source current because of the internal pull-ups. Port 2 emits the high-order address byte during fetches from external program memory and during accesses to external data memory that use 16-bit addresses (MOVX @DPTR). In this application, it uses strong internal pull-ups emitting 1s. During accesses to external data memory that use 8-bit addresses (MOVX @Ri), port 2 emits the contents of the P2 SFR. Some Port 2 pins (P2.0 to P2.5) receive the high order address bits during EPROM programming and verification:
P3.0-P3.7	10-17	11, 13-19	5, 7-13	I/O	<b>Port 3:</b> Port 3 is an 8-bit bidirectional I/O port with internal pull-ups. Port 3 pins that have 1s written to them are pulled high by the internal pull-ups and can be used as inputs. As inputs, Port 3 pins that are externally pulled low will source current because of the internal pull-ups. Some Port 3 pins (P3.4 to P3.5) receive the high order address bits during EPROM programming and verification. Port 3 also serves the special features of the 80C51 family, as listed below.
	10	11	5	I	<b>RXD (P3.0):</b> Serial input port
	11	13	7	O	<b>TXD (P3.1):</b> Serial output port
	12	14	8	I	<b>INT0 (P3.2):</b> External interrupt 0
	13	15	9	I	<b>INT1 (P3.3):</b> External interrupt 1
	14	16	10	I	<b>T0 (P3.4):</b> Timer 0 external input
	15	17	11	I	<b>T1 (P3.5):</b> Timer 1 external input
	16	18	12	O	<b>WR (P3.6):</b> External data memory write strobe
	17	19	13	O	<b>RD (P3.7):</b> External data memory read strobe



**TS80C51RA2/RD2**  
**TS83C51RB2/RC2/RD2**  
**TS87C51RB2/RC2/RD2**

Reset	9	10	4	I	<b>Reset:</b> A high on this pin for two machine cycles while the oscillator is running, resets the device. An internal diffused resistor to $V_{SS}$ permits a power-on reset using only an external capacitor to $V_{CC}$ . If the hardware watchdog reaches its time-out, the reset pin becomes an output during the time the internal reset is activated.
-------	---	----	---	---	---

**TS80C51RA2/RD2**  
**TS83C51RB2/RC2/RD2**  
**TS87C51RB2/RC2/RD2**



Mnemonic	Pin Number			Type	Name And Function
ALE/ $\overline{\text{PROG}}$	30	33	27	O (I)	<b>Address Latch Enable/Program Pulse:</b> Output pulse for latching the low byte of the address during an access to external memory. In normal operation, ALE is emitted at a constant rate of 1/6 (1/3 in X2 mode) the oscillator frequency, and can be used for external timing or clocking. Note that one ALE pulse is skipped during each access to external data memory. This pin is also the program pulse input (PROG) during EPROM programming. ALE can be disabled by setting SFR's AUXR.0 bit. With this bit set, ALE will be inactive during internal fetches.
$\overline{\text{PSEN}}$	29	32	26	O	<b>Program Store ENable:</b> The read strobe to external program memory. When executing code from the external program memory, $\overline{\text{PSEN}}$ is activated twice each machine cycle, except that two $\overline{\text{PSEN}}$ activations are skipped during each access to external data memory. $\overline{\text{PSEN}}$ is not activated during fetches from internal program memory.
$\overline{\text{EA}}/\text{V}_{\text{pp}}$	31	35	29	I	<b>External Access Enable/Programming Supply Voltage:</b> $\overline{\text{EA}}$ must be externally held low to enable the device to fetch code from external program memory locations 0000H and 3FFFH (RB) or 7FFFH (RC), or FFFFH (RD). If EA is held high, the device executes from internal program memory unless the program counter contains an address greater than 3FFFH (RB) or 7FFFH (RC) $\overline{\text{EA}}$ must be held low for ROMless devices. This pin also receives the 12.75V programming supply voltage ( $\text{V}_{\text{pp}}$ ) during EPROM programming. If security level 1 is programmed, $\overline{\text{EA}}$ will be internally latched on Reset.
XTAL1	19	21	15	I	<b>Crystal 1:</b> Input to the inverting oscillator amplifier and input to the internal clock generator circuits.
XTAL2	18	20	14	O	<b>Crystal 2:</b> Output from the inverting oscillator amplifier



### 5.1. Pin Description for 64/68 pin Packages

Port 4 and Port 5 are 8-bit bidirectional I/O ports with internal pull-ups. Pins that have 1 written to them are pulled high by the internal pull ups and can be used as inputs.

As inputs, pins that are externally pulled low will source current because of the internal pull-ups.

Refer to the previous pin description for other pins.

**Table 2. 64/68 Pin Packages Configuration**

	PLCC68	SQUARE VQFP64 1.4
VSS	51	9/40
VCC	17	8
P0.0	15	6
P0.1	14	5
P0.2	12	3
P0.3	11	2
P0.4	9	64
P0.5	6	61
P0.6	5	60
P0.7	3	59
P1.0	19	10
P1.1	21	12
P1.2	22	13
P1.3	23	14
P1.4	25	16
P1.5	27	18
P1.6	28	19
P1.7	29	20
P2.0	54	43
P2.1	55	44
P2.2	56	45
P2.3	58	47
P2.4	59	48
P2.5	61	50
P2.6	64	53
P2.7	65	54
P3.0	34	25
P3.1	39	28

	PLCC68	SQUARE VQFP64 1.4
P3.2	40	29
P3.3	41	30
P3.4	42	31
P3.5	43	32
P3.6	45	34
P3.7	47	36
RESET	30	21
ALE/PROG	68	56
PSEN	67	55
EA/VPP	2	58
XTAL1	49	38
XTAL2	48	37
P4.0	20	11
P4.1	24	15
P4.2	26	17
P4.3	44	33
P4.4	46	35
P4.5	50	39
P4.6	53	42
P4.7	57	46
P5.0	60	49
P5.1	62	51
P5.2	63	52
P5.3	7	62
P5.4	8	63
P5.5	10	1
P5.6	13	4
P5.7	16	7

## 6. TS80C51Rx2 Enhanced Features

In comparison to the original 80C52, the TS80C51Rx2 implements some new features, which are:

- The X2 option.
- The Dual Data Pointer.
- The extended RAM.
- The Programmable Counter Array (PCA).
- The Watchdog.
- The 4 level interrupt priority system.
- The power-off flag.
- The ONCE mode.
- The ALE disabling.
- Some enhanced features are also located in the UART and the timer 2.

### 6.1. X2 Feature

The TS80C51Rx2 core needs only 6 clock periods per machine cycle. This feature called "X2" provides the following advantages:

- Divide frequency crystals by 2 (cheaper crystals) while keeping same CPU power.
- Save power consumption while keeping same CPU power (oscillator power saving).
- Save power consumption by dividing dynamically operating frequency by 2 in operating and idle modes.
- Increase CPU power by 2 while keeping same crystal frequency.

In order to keep the original C51 compatibility, a divider by 2 is inserted between the XTAL1 signal and the main clock input of the core (phase generator). This divider may be disabled by software.

#### 6.1.1. Description

The clock for the whole circuit and peripheral is first divided by two before being used by the CPU core and peripherals. This allows any cyclic ratio to be accepted on XTAL1 input. In X2 mode, as this divider is bypassed, the signals on XTAL1 must have a cyclic ratio between 40 to 60%. Figure 1. shows the clock generation block diagram. X2 bit is validated on XTAL1÷2 rising edge to avoid glitches when switching from X2 to STD mode. Figure 2. shows the mode switching waveforms.

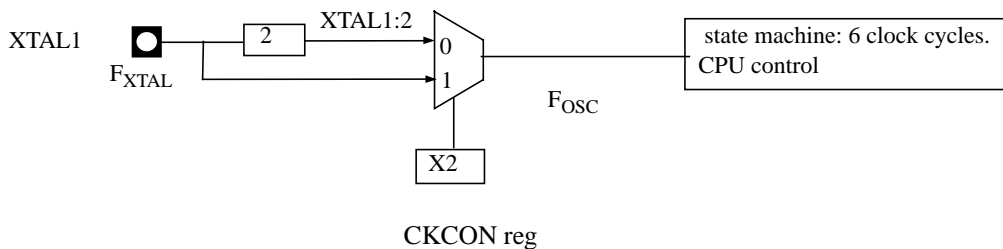

**Figure 1. Clock Generation Diagram**

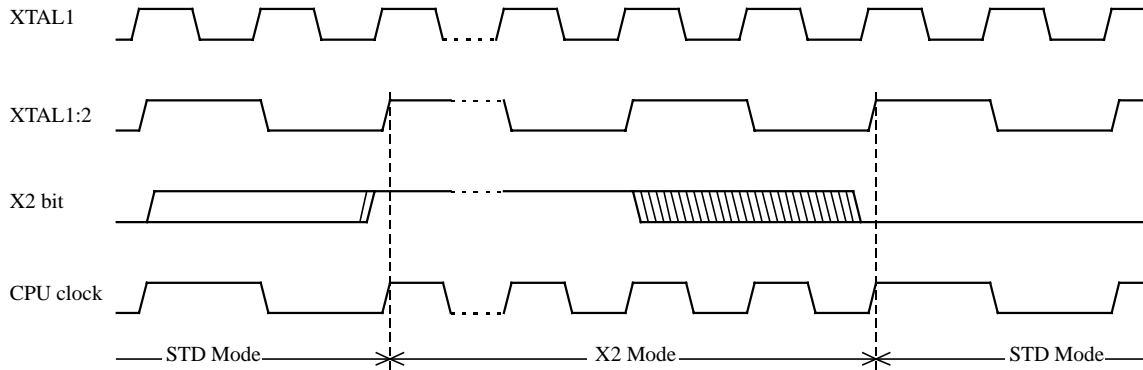

**Figure 2. Mode Switching Waveforms**

The X2 bit in the CKCON register (See Table 3.) allows to switch from 12 clock cycles per instruction to 6 clock cycles and vice versa. At reset, the standard speed is activated (STD mode). Setting this bit activates the X2 feature (X2 mode).

**CAUTION**

In order to prevent any incorrect operation while operating in X2 mode, user must be aware that all peripherals using clock frequency as time reference (UART, timers, PCA...) will have their time reference divided by two. For example a free running timer generating an interrupt every 20 ms will then generate an interrupt every 10 ms. UART with 4800 baud rate will have 9600 baud rate.

**Table 3. CKCON Register**

**CKCON - Clock Control Register (8Fh)**

7	6	5	4	3	2	1	0
-	-	-	-	-	-	-	<b>X2</b>

Bit Number	Bit Mnemonic	Description
7	-	<b>Reserved</b> The value read from this bit is indeterminate. Do not set this bit.
6	-	<b>Reserved</b> The value read from this bit is indeterminate. Do not set this bit.
5	-	<b>Reserved</b> The value read from this bit is indeterminate. Do not set this bit.
4	-	<b>Reserved</b> The value read from this bit is indeterminate. Do not set this bit.
3	-	<b>Reserved</b> The value read from this bit is indeterminate. Do not set this bit.
2	-	<b>Reserved</b> The value read from this bit is indeterminate. Do not set this bit.
1	-	<b>Reserved</b> The value read from this bit is indeterminate. Do not set this bit.
0	X2	<b>CPU and peripheral clock bit</b> Clear to select 12 clock periods per machine cycle (STD mode, $F_{OSC}=F_{XTAL}/2$ ). Set to select 6 clock periods per machine cycle (X2 mode, $F_{OSC}=F_{XTAL}$ ).

Reset Value = XXXX XXX0b

Not bit addressable

For further details on the X2 feature, please refer to ANM072 available on the web (<http://www.atmel-wm.com>)

## 6.2. Dual Data Pointer Register Ddptr

The additional data pointer can be used to speed up code execution and reduce code size in a number of ways.

The dual DPTR structure is a way by which the chip will specify the address of an external data memory location. There are two 16-bit DPTR registers that address the external memory, and a single bit called DPS = AUXR1/bit0 (See Table 4.) that allows the program code to switch between them (Refer to Figure 3).

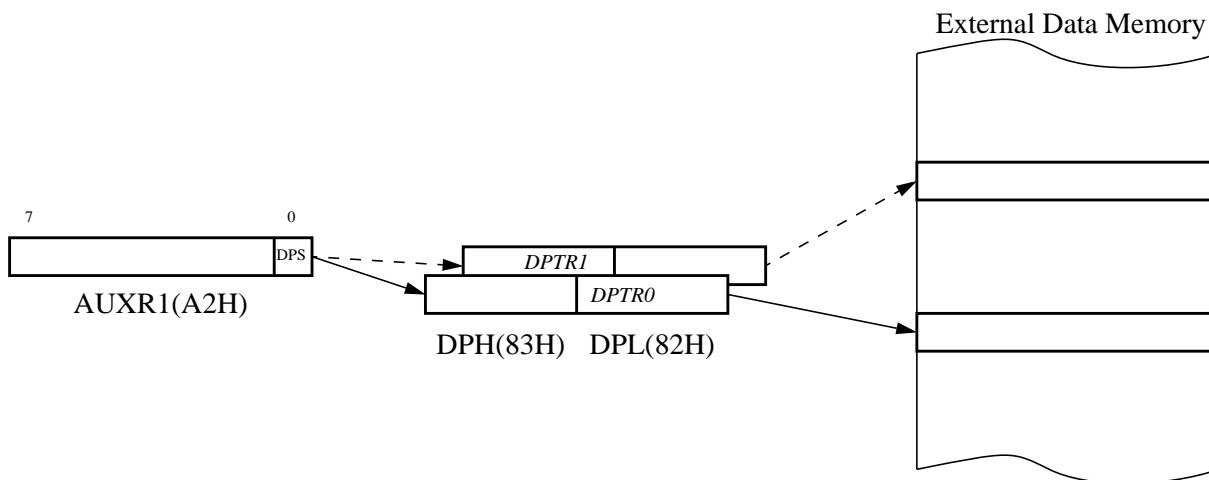

Figure 3. Use of Dual Pointer

Table 4. AUXR1: Auxiliary Register 1

AUXR1 Address 0A2H	-	-	-	-	GF3	-	-	DPS
Reset value	X	X	X	X	0	X	X	0

Symbol	Function
-	Not implemented, reserved for future use. <sup>a</sup>
DPS	Data Pointer Selection.
	<b>DPS</b> <b>Operating Mode</b>
	0              DPTR0 Selected
1              DPTR1 Selected	
GF3	This bit is a general purpose user flag <sup>b</sup> .

- a. User software should not write 1s to reserved bits. These bits may be used in future 8051 family products to invoke new feature. In that case, the reset value of the new bit will be 0, and its active value will be 1. The value read from a reserved bit is indeterminate.
- b. GF3 will not be available on first version of the RC devices.

### Application

Software can take advantage of the additional data pointers to both increase speed and reduce code size, for example, block operations (copy, compare, search ...) are well served by using one data pointer as a 'source' pointer and the other one as a "destination" pointer.

ASSEMBLY LANGUAGE

```

; Block move using dual data pointers
; Destroys DPTR0, DPTR1, A and PSW
; note: DPS exits opposite of entry state
; unless an extra INC AUXR1 is added
;
00A2          AUXR1 EQU 0A2H
;
0000 909000   MOV DPTR,#SOURCE      ; address of SOURCE
0003 05A2     INC  AUXR1           ; switch data pointers
0005 90A000   MOV DPTR,#DEST      ; address of DEST
0008          LOOP:
0008 05A2     INC  AUXR1           ; switch data pointers
000A E0       MOVX A,@DPTR        ; get a byte from SOURCE
000B A3       INC  DPTR           ; increment SOURCE address
000C 05A2     INC  AUXR1           ; switch data pointers
000E F0       MOVX @DPTR,A        ; write the byte to DEST
000F A3       INC  DPTR           ; increment DEST address
0010 70F6     JNZ  LOOP           ; check for 0 terminator
0012 05A2     INC  AUXR1         ; (optional) restore DPS

```

INC is a short (2 bytes) and fast (12 clocks) way to manipulate the DPS bit in the AUXR1 SFR. However, note that the INC instruction does not directly force the DPS bit to a particular state, but simply toggles it. In simple routines, such as the block move example, only the fact that DPS is toggled in the proper sequence matters, not its actual value. In other words, the block move routine works the same whether DPS is '0' or '1' on entry. Observe that without the last instruction (INC AUXR1), the routine will exit with DPS in the opposite state.

### 6.3. Expanded RAM (XRAM)

The TS80C51Rx2 provide additional Bytes of random access memory (RAM) space for increased data parameter handling and high level language usage.

RA2, RB2 and RC2 devices have 256 bytes of expanded RAM, from 00H to FFH in external data space; RD2 devices have 768 bytes of expanded RAM, from 00H to 2FFH in external data space.

The TS80C51Rx2 has internal data memory that is mapped into four separate segments.

The four segments are:

- 1. The Lower 128 bytes of RAM (addresses 00H to 7FH) are directly and indirectly addressable.
- 2. The Upper 128 bytes of RAM (addresses 80H to FFH) are indirectly addressable only.
- 3. The Special Function Registers, SFRs, (addresses 80H to FFH) are directly addressable only.
- 4. The expanded RAM bytes are indirectly accessed by MOVX instructions, and with the EXTRAM bit cleared in the AUXR register. (See Table 5.)

The Lower 128 bytes can be accessed by either direct or indirect addressing. The Upper 128 bytes can be accessed by indirect addressing only. The Upper 128 bytes occupy the same address space as the SFR. That means they have the same address, but are physically separate from SFR space.

When an instruction accesses an internal location above address 7FH, the CPU knows whether the access is to the upper 128 bytes of data RAM or to SFR space by the addressing mode used in the instruction.

- Instructions that use direct addressing access SFR space. **For example: MOV 0A0H, # data** ,accesses the SFR at location 0A0H (which is P2).
- Instructions that use indirect addressing access the Upper 128 bytes of data RAM. **For example: MOV @R0, # data** where R0 contains 0A0H, accesses the data byte at address 0A0H, rather than P2 (whose address is 0A0H).
- The 256 or 768 XRAM bytes can be accessed by indirect addressing, with EXTRAM bit cleared and MOVX instructions. This part of memory which is physically located on-chip, logically occupies the first 256 or 768 bytes of external data memory.
- With EXTRAM = 0, the XRAM is indirectly addressed, using the MOVX instruction in combination with any of the registers R0, R1 of the selected bank or DPTR. **An access to XRAM will not affect ports P0, P2, P3.6 ( $\overline{WR}$ ) and P3.7 ( $\overline{RD}$ ).** **For example, with EXTRAM = 0, MOVX @R0, # data** where R0 contains 0A0H, accesses the XRAM at address 0A0H rather than external memory. An access to external data memory locations higher than FFH (i.e. 0100H to FFFFH) (higher than 2FFH (i.e. 0300H to FFFFH for RD devices) will be performed with the MOVX DPTR instructions in the same way as in the standard 80C51, so with P0 and P2 as data/address busses, and P3.6 and P3.7 as write and read timing signals. Refer to Figure . For RD devices, accesses to expanded RAM from 100H to 2FFH can only be done thanks to the use of DPTR.
- With EXTRAM = 1, MOVX @Ri and MOVX @DPTR will be similar to the standard 80C51. MOVX @ Ri will provide an eight-bit address multiplexed with data on Port0 and any output port pins can be used to output higher order address bits. This is to provide the external paging capability. MOVX @DPTR will generate a sixteen-bit address. Port2 outputs the high-order eight address bits (the contents of DPH) while Port0 multiplexes the low-order eight address bits (DPL) with data. MOVX @ Ri and MOVX @DPTR will generate either read or write signals on P3.6 ( $\overline{WR}$ ) and P3.7 ( $\overline{RD}$ ).

The stack pointer (SP) may be located anywhere in the 256 bytes RAM (lower and upper RAM) internal data memory. The stack may not be located in the XRAM.



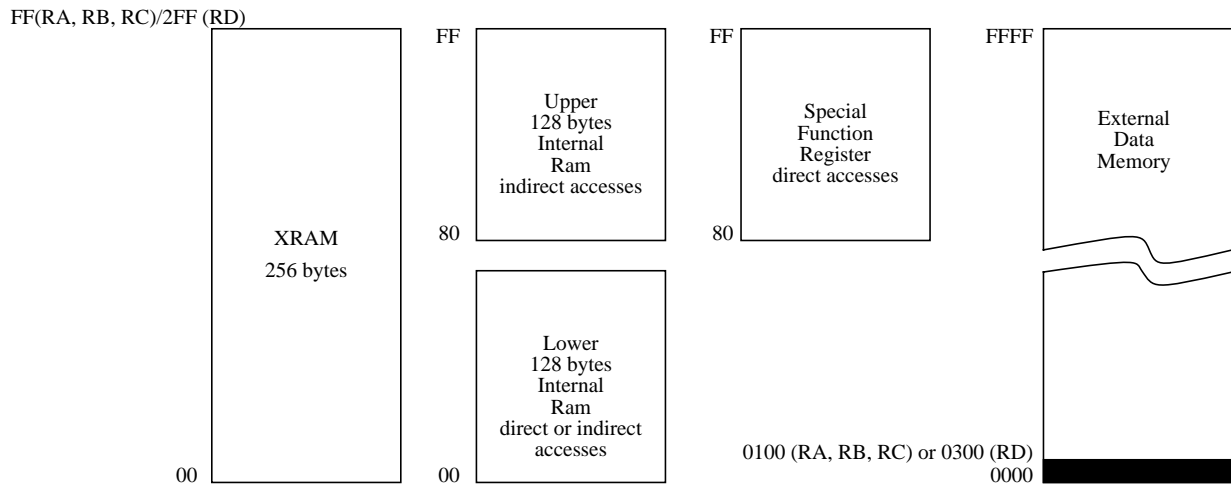

Figure 4. Internal and External Data Memory Address

Table 5. Auxiliary Register AUXR

AUXR Address 08EH	-	-	-	-	-	-	EXTRA M	AO
Reset value	X	X	X	X	X	X	0	0

Symbol	Function	
-	Not implemented, reserved for future use. <sup>a</sup>	
AO	Disable/Enable ALE	
	AO	Operating Mode
	0	ALE is emitted at a constant rate of 1/6 the oscillator frequency (or 1/3 if X2 mode is used)
1	ALE is active only during a MOVX or MOVC instruction	
EXTRAM	Internal/External RAM (00H-FFH) access using MOVX @ Ri/ @ DPTR	
	EXTRAM	Operating Mode
	0	Internal XRAM access using MOVX @ Ri/ @ DPTR
1	External data memory access	

a. User software should not write 1s to reserved bits. These bits may be used in future 8051 family products to invoke new features. In that case, the reset or inactive value of the new bit will be 0, and its active value will be 1. The value read from a reserved bit is indeterminate.

## 6.4. Timer 2

The timer 2 in the TS80C51RX2 is compatible with the timer 2 in the 80C52.

It is a 16-bit timer/counter: the count is maintained by two eight-bit timer registers, TH2 and TL2, connected in cascade. It is controlled by T2CON register (See Table 6) and T2MOD register (See Table 7). Timer 2 operation is similar to Timer 0 and Timer 1.  $C/\overline{T2}$  selects  $F_{OSC}/12$  (timer operation) or external pin T2 (counter operation) as the timer clock input. Setting TR2 allows TL2 to be incremented by the selected input.

Timer 2 has 3 operating modes: capture, autoreload and Baud Rate Generator. These modes are selected by the combination of RCLK, TCLK and  $CP/\overline{RL2}$  (T2CON), as described in the Atmel Wireless & Microcontrollers 8-bit Microcontroller Hardware description.

Refer to the Atmel Wireless & Microcontrollers 8-bit Microcontroller Hardware description for the description of Capture and Baud Rate Generator Modes.

In TS80C51RX2 Timer 2 includes the following enhancements:

- Auto-reload mode with up or down counter
- Programmable clock-output

### 6.4.1. Auto-Reload Mode

The auto-reload mode configures timer 2 as a 16-bit timer or event counter with automatic reload. If DCEN bit in T2MOD is cleared, timer 2 behaves as in 80C52 (refer to the Atmel Wireless & Microcontrollers 8-bit Microcontroller Hardware description). If DCEN bit is set, timer 2 acts as an Up/down timer/counter as shown in Figure 5. In this mode the T2EX pin controls the direction of count.

When T2EX is high, timer 2 counts up. Timer overflow occurs at FFFFh which sets the TF2 flag and generates an interrupt request. The overflow also causes the 16-bit value in RCAP2H and RCAP2L registers to be loaded into the timer registers TH2 and TL2.

When T2EX is low, timer 2 counts down. Timer underflow occurs when the count in the timer registers TH2 and TL2 equals the value stored in RCAP2H and RCAP2L registers. The underflow sets TF2 flag and reloads FFFFh into the timer registers.

The EXF2 bit toggles when timer 2 overflows or underflows according to the the direction of the count. EXF2 does not generate any interrupt. This bit can be used to provide 17-bit resolution.

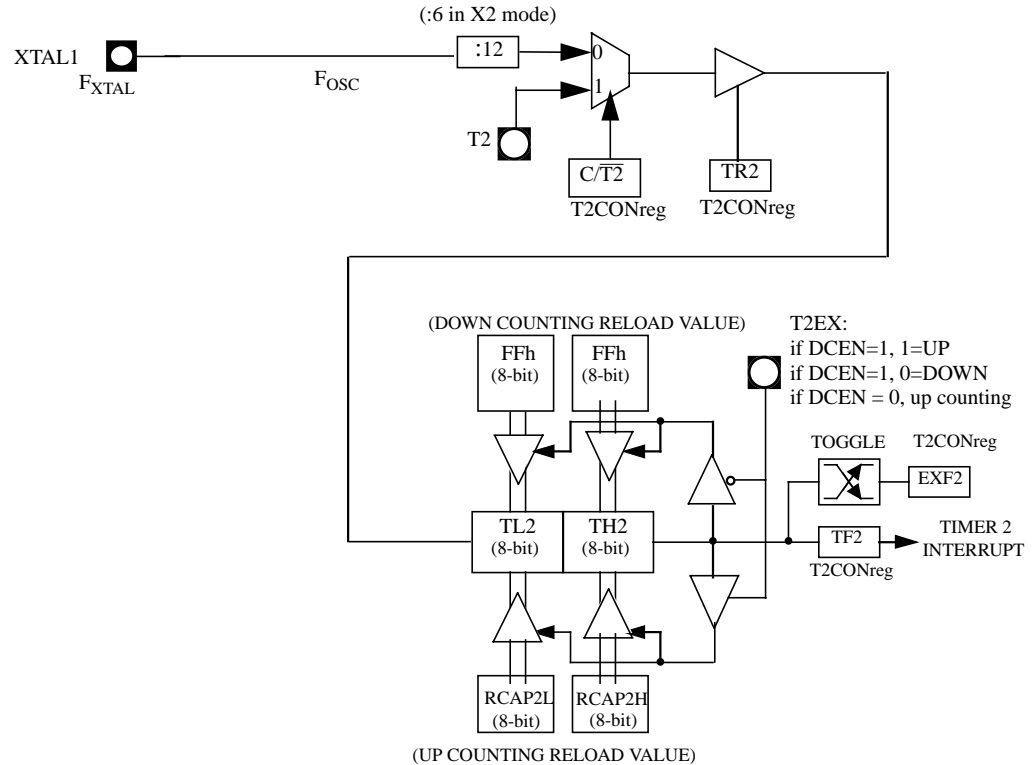

**Figure 5. Auto-Reload Mode Up/Down Counter (DCEN = 1)**

### 6.4.2. Programmable Clock-Output

In the clock-out mode, timer 2 operates as a 50%-duty-cycle, programmable clock generator (See Figure 6) . The input clock increments TL2 at frequency  $F_{OSC}/2$ . The timer repeatedly counts to overflow from a loaded value. At overflow, the contents of RCAP2H and RCAP2L registers are loaded into TH2 and TL2. In this mode, timer 2 overflows do not generate interrupts. The formula gives the clock-out frequency as a function of the system oscillator frequency and the value in the RCAP2H and RCAP2L registers :

$$Clock - OutFrequency = \frac{F_{osc}}{4 \times (65536 - RCAP2H/RCAP2L)}$$

For a 16 MHz system clock, timer 2 has a programmable frequency range of 61 Hz ( $F_{OSC}/2^{16}$ ) to 4 MHz ( $F_{OSC}/4$ ). The generated clock signal is brought out to T2 pin (P1.0).

Timer 2 is programmed for the clock-out mode as follows:

- Set T2OE bit in T2MOD register.
- Clear  $C/\overline{T2}$  bit in T2CON register.
- Determine the 16-bit reload value from the formula and enter it in RCAP2H/RCAP2L registers.
- Enter a 16-bit initial value in timer registers TH2/TL2. It can be the same as the reload value or a different one depending on the application.
- To start the timer, set TR2 run control bit in T2CON register.

It is possible to use timer 2 as a baud rate generator and a clock generator simultaneously. For this configuration, the baud rates and clock frequencies are not independent since both functions use the values in the RCAP2H and RCAP2L registers.

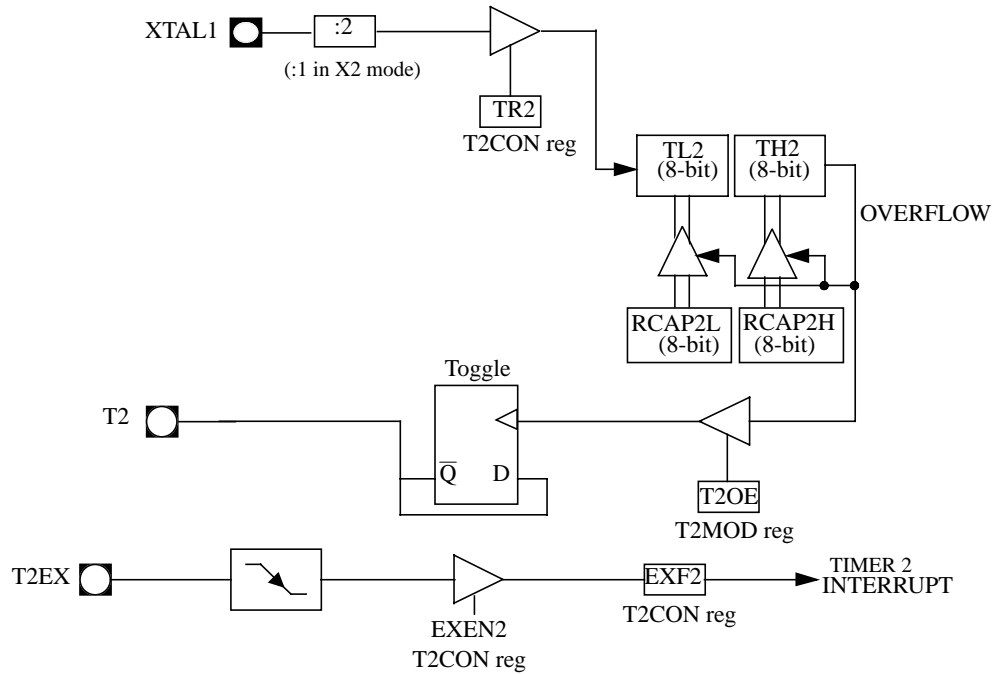

**Figure 6. Clock-Out Mode  $C/\overline{T2} = 0$**

**Table 6. T2CON Register**

T2CON - Timer 2 Control Register (C8h)

7	6	5	4	3	2	1	0
TF2	EXF2	RCLK	TCLK	EXEN2	TR2	C/T2#	CP/RL2#
Bit Number	Bit Mnemonic	Description					
7	TF2	<b>Timer 2 overflow Flag</b> Must be cleared by software. Set by hardware on timer 2 overflow, if RCLK = 0 and TCLK = 0.					
6	EXF2	<b>Timer 2 External Flag</b> Set when a capture or a reload is caused by a negative transition on T2EX pin if EXEN2=1. When set, causes the CPU to vector to timer 2 interrupt routine when timer 2 interrupt is enabled. Must be cleared by software. EXF2 doesn't cause an interrupt in Up/down counter mode (DCEN = 1)					
5	RCLK	<b>Receive Clock bit</b> Clear to use timer 1 overflow as receive clock for serial port in mode 1 or 3. Set to use timer 2 overflow as receive clock for serial port in mode 1 or 3.					
4	TCLK	<b>Transmit Clock bit</b> Clear to use timer 1 overflow as transmit clock for serial port in mode 1 or 3. Set to use timer 2 overflow as transmit clock for serial port in mode 1 or 3.					
3	EXEN2	<b>Timer 2 External Enable bit</b> Clear to ignore events on T2EX pin for timer 2 operation. Set to cause a capture or reload when a negative transition on T2EX pin is detected, if timer 2 is not used to clock the serial port.					
2	TR2	<b>Timer 2 Run control bit</b> Clear to turn off timer 2. Set to turn on timer 2.					
1	C/T2#	<b>Timer/Counter 2 select bit</b> Clear for timer operation (input from internal clock system: F <sub>OSC</sub> ). Set for counter operation (input from T2 input pin, falling edge trigger). Must be 0 for clock out mode.					
0	CP/RL2#	<b>Timer 2 Capture/Reload bit</b> If RCLK=1 or TCLK=1, CP/RL2# is ignored and timer is forced to auto-reload on timer 2 overflow. Clear to auto-reload on timer 2 overflows or negative transitions on T2EX pin if EXEN2=1. Set to capture on negative transitions on T2EX pin if EXEN2=1.					

Reset Value = 0000 0000b

Bit addressable

Table 7. T2MOD Register

T2MOD - Timer 2 Mode Control Register (C9h)

7	6	5	4	3	2	1	0
-	-	-	-	-	-	T2OE	DCEN

Bit Number	Bit Mnemonic	Description
7	-	<b>Reserved</b> The value read from this bit is indeterminate. Do not set this bit.
6	-	<b>Reserved</b> The value read from this bit is indeterminate. Do not set this bit.
5	-	<b>Reserved</b> The value read from this bit is indeterminate. Do not set this bit.
4	-	<b>Reserved</b> The value read from this bit is indeterminate. Do not set this bit.
3	-	<b>Reserved</b> The value read from this bit is indeterminate. Do not set this bit.
2	-	<b>Reserved</b> The value read from this bit is indeterminate. Do not set this bit.
1	T2OE	<b>Timer 2 Output Enable bit</b> Clear to program P1.0/T2 as clock input or I/O port. Set to program P1.0/T2 as clock output.
0	DCEN	<b>Down Counter Enable bit</b> Clear to disable timer 2 as up/down counter. Set to enable timer 2 as up/down counter.

Reset Value = XXXX XX00b

Not bit addressable

## 6.5. Programmable Counter Array PCA

The PCA provides more timing capabilities with less CPU intervention than the standard timer/counters. Its advantages include reduced software overhead and improved accuracy. The PCA consists of a dedicated timer/counter which serves as the time base for an array of five compare/ capture modules. Its clock input can be programmed to count any one of the following signals:

- Oscillator frequency  $\div 12$  ( $\div 6$  in X2 mode)
- Oscillator frequency  $\div 4$  ( $\div 2$  in X2 mode)
- Timer 0 overflow
- External input on ECI (P1.2)

Each compare/capture modules can be programmed in any one of the following modes:

- rising and/or falling edge capture,
- software timer,
- high-speed output, or
- pulse width modulator.

Module 4 can also be programmed as a watchdog timer (See Section "PCA Watchdog Timer", page 33).

When the compare/capture modules are programmed in the capture mode, software timer, or high speed output mode, an interrupt can be generated when the module executes its function. All five modules plus the PCA timer overflow share one interrupt vector.

The PCA timer/counter and compare/capture modules share Port 1 for external I/O. These pins are listed below. If the port is not used for the PCA, it can still be used for standard I/O.

PCA component	External I/O Pin
16-bit Counter	P1.2 / ECI
16-bit Module 0	P1.3 / CEX0
16-bit Module 1	P1.4 / CEX1
16-bit Module 2	P1.5 / CEX2
16-bit Module 3	P1.6 / CEX3
16-bit Module 4	P1.7 / CEX4

**The PCA timer** is a common time base for all five modules (See Figure 7). The timer count source is determined from the CPS1 and CPS0 bits in the **CMOD SFR** (See Table 8) and can be programmed to run at:

- 1/12 the oscillator frequency. (Or 1/6 in X2 Mode)
- 1/4 the oscillator frequency. (Or 1/2 in X2 Mode)
- The Timer 0 overflow
- The input on the ECI pin (P1.2)

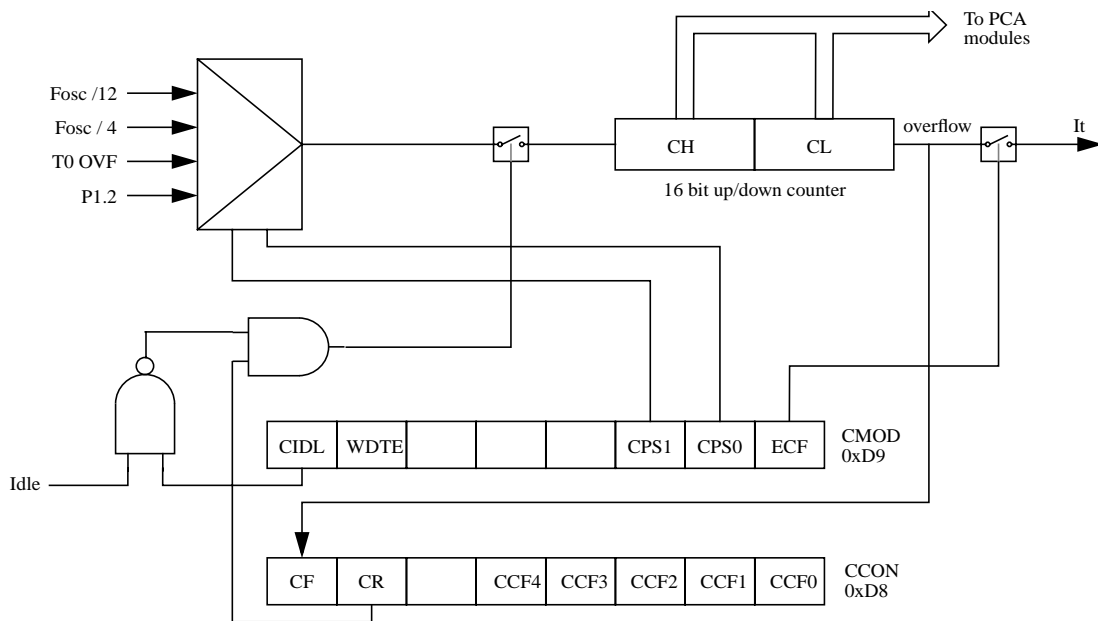

Figure 7. PCA Timer/Counter

Table 8. CMOD: PCA Counter Mode Register

CMOD Address 0D9H	CIDL	WDTE	-	-	-	CPS1	CPS0	ECF
Reset value	0	0	X	X	X	0	0	0

Symbol	Function															
<b>CIDL</b>	Counter Idle control: CIDL = 0 programs the PCA Counter to continue functioning during idle Mode. CIDL = 1 programs it to be gated off during idle.															
<b>WDTE</b>	Watchdog Timer Enable: WDTE = 0 disables Watchdog Timer function on PCA Module 4. WDTE = 1 enables it.															
-	Not implemented, reserved for future use. <sup>a</sup>															
<b>CPS1</b>	PCA Count Pulse Select bit 1.															
<b>CPS0</b>	PCA Count Pulse Select bit 0.															
	<table border="1"> <thead> <tr> <th>CPS1</th> <th>CPS0</th> <th>Selected PCA input.<sup>b</sup></th> </tr> </thead> <tbody> <tr> <td>0</td> <td>0</td> <td>Internal clock <math>f_{osc}/12</math> ( Or <math>f_{osc}/6</math> in X2 Mode).</td> </tr> <tr> <td>0</td> <td>1</td> <td>Internal clock <math>f_{osc}/4</math> ( Or <math>f_{osc}/2</math> in X2 Mode).</td> </tr> <tr> <td>1</td> <td>0</td> <td>Timer 0 Overflow</td> </tr> <tr> <td>1</td> <td>1</td> <td>External clock at ECI/P1.2 pin (max rate = <math>f_{osc}/8</math>)</td> </tr> </tbody> </table>	CPS1	CPS0	Selected PCA input. <sup>b</sup>	0	0	Internal clock $f_{osc}/12$ ( Or $f_{osc}/6$ in X2 Mode).	0	1	Internal clock $f_{osc}/4$ ( Or $f_{osc}/2$ in X2 Mode).	1	0	Timer 0 Overflow	1	1	External clock at ECI/P1.2 pin (max rate = $f_{osc}/8$ )
CPS1	CPS0	Selected PCA input. <sup>b</sup>														
0	0	Internal clock $f_{osc}/12$ ( Or $f_{osc}/6$ in X2 Mode).														
0	1	Internal clock $f_{osc}/4$ ( Or $f_{osc}/2$ in X2 Mode).														
1	0	Timer 0 Overflow														
1	1	External clock at ECI/P1.2 pin (max rate = $f_{osc}/8$ )														
<b>ECF</b>	PCA Enable Counter Overflow interrupt: ECF = 1 enables CF bit in CCON to generate an interrupt. ECF = 0 disables that function of CF.															

- a. User software should not write 1s to reserved bits. These bits may be used in future 8051 family products to invoke new features. In that case, the reset or inactive value of the new bit will be 0, and its active value will be 1. The value read from a reserved bit is indeterminate.
- b.  $f_{osc}$  = oscillator frequency

The CMOD SFR includes three additional bits associated with the PCA (See Figure 7 and Table 8).

- The CIDL bit which allows the PCA to stop during idle mode.
- The WDTE bit which enables or disables the watchdog function on module 4.



- The ECF bit which when set causes an interrupt and the PCA overflow flag CF (in the CCON SFR) to be set when the PCA timer overflows.

The **CCON SFR** contains the run control bit for the PCA and the flags for the PCA timer (CF) and each module (Refer to Table 9).

- Bit CR (CCON.6) must be set by software to run the PCA. The PCA is shut off by clearing this bit.
- Bit CF: The CF bit (CCON.7) is set when the PCA counter overflows and an interrupt will be generated if the ECF bit in the CMOD register is set. The CF bit can only be cleared by software.
- Bits 0 through 4 are the flags for the modules (bit 0 for module 0, bit 1 for module 1, etc.) and are set by hardware when either a match or a capture occurs. These flags also can only be cleared by software.

**Table 9. CCON: PCA Counter Control Register**

CCON Address 0D8H		CF	CR	-	CCF4	CCF3	CCF2	CCF1	CCF0
Reset value		0	0	X	0	0	0	0	0
Symbol	Function								
CF	PCA Counter Overflow flag. Set by hardware when the counter rolls over. CF flags an interrupt if bit ECF in CMOD is set. CF may be set by either hardware or software but can only be cleared by software.								
CR	PCA Counter Run control bit. Set by software to turn the PCA counter on. Must be cleared by software to turn the PCA counter off.								
-	Not implemented, reserved for future use. <sup>a</sup>								
CCF4	PCA Module 4 interrupt flag. Set by hardware when a match or capture occurs. Must be cleared by software.								
CCF3	PCA Module 3 interrupt flag. Set by hardware when a match or capture occurs. Must be cleared by software.								
CCF2	PCA Module 2 interrupt flag. Set by hardware when a match or capture occurs. Must be cleared by software.								
CCF1	PCA Module 1 interrupt flag. Set by hardware when a match or capture occurs. Must be cleared by software.								
CCF0	PCA Module 0 interrupt flag. Set by hardware when a match or capture occurs. Must be cleared by software.								

a. User software should not write 1s to reserved bits. These bits may be used in future 8051 family products to invoke new features. In that case, the reset or inactive value of the new bit will be 0, and its active value will be 1. The value read from a reserved bit is indeterminate.

The **watchdog timer** function is implemented in module 4 (See Figure 10).

The **PCA interrupt** system is shown in Figure 8

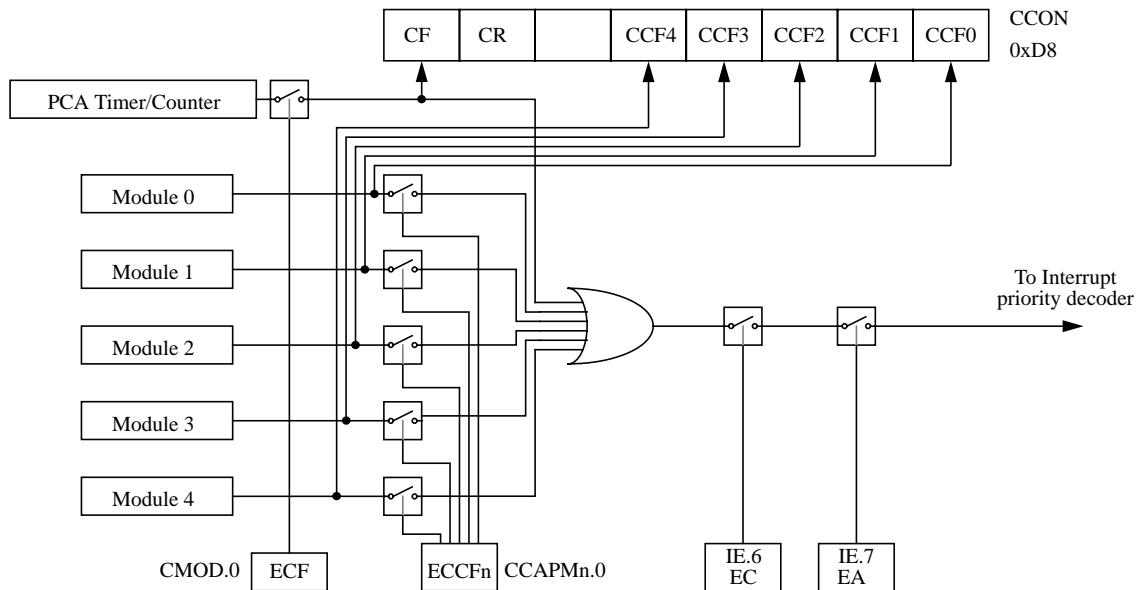

Figure 8. PCA Interrupt System

**PCA Modules:** each one of the five compare/capture modules has six possible functions. It can perform:

- 16-bit Capture, positive-edge triggered,
- 16-bit Capture, negative-edge triggered,
- 16-bit Capture, both positive and negative-edge triggered,
- 16-bit Software Timer,
- 16-bit High Speed Output,
- 8-bit Pulse Width Modulator.

In addition, module 4 can be used as a Watchdog Timer.

Each module in the PCA has a special function register associated with it. These registers are: CCAPM0 for module 0, CCAPM1 for module 1, etc. (See Table 10). The registers contain the bits that control the mode that each module will operate in.

- The ECCF bit (CCAPMn.0 where n=0, 1, 2, 3, or 4 depending on the module) enables the CCF flag in the CCON SFR to generate an interrupt when a match or compare occurs in the associated module.
- PWM (CCAPMn.1) enables the pulse width modulation mode.
- The TOG bit (CCAPMn.2) when set causes the CEX output associated with the module to toggle when there is a match between the PCA counter and the module's capture/compare register.
- The match bit MAT (CCAPMn.3) when set will cause the CCFn bit in the CCON register to be set when there is a match between the PCA counter and the module's capture/compare register.
- The next two bits CAPN (CCAPMn.4) and CAPP (CCAPMn.5) determine the edge that a capture input will be active on. The CAPN bit enables the negative edge, and the CAPP bit enables the positive edge. If both bits are set both edges will be enabled and a capture will occur for either transition.
- The last bit in the register ECOM (CCAPMn.6) when set enables the comparator function.

Table 11 shows the CCAPMn settings for the various PCA functions.

Table 10. CCAPMn: PCA Modules Compare/Capture Control Registers

CCAPMn Address n = 0 - 4	CCAPM0=0DAH CCAPM1=0DBH CCAPM2=0DCH CCAPM3=0DDH CCAPM4=0DEH							
		-	ECOMn	CAPPn	CAPNn	MATn	TOGn	PWMm
Reset value	X	0	0	0	0	0	0	0

Symbol	Function
-	Not implemented, reserved for future use. <sup>a</sup>
ECOMn	Enable Comparator. ECOMn = 1 enables the comparator function.
CAPPn	Capture Positive, CAPPn = 1 enables positive edge capture.
CAPNn	Capture Negative, CAPNn = 1 enables negative edge capture.
MATn	Match. When MATn = 1, a match of the PCA counter with this module's compare/capture register causes the CCFn bit in CCON to be set, flagging an interrupt.
TOGn	Toggle. When TOGn = 1, a match of the PCA counter with this module's compare/capture register causes the CEXn pin to toggle.
PWMn	Pulse Width Modulation Mode. PWMn = 1 enables the CEXn pin to be used as a pulse width modulated output.
ECCFn	Enable CCF interrupt. Enables compare/capture flag CCFn in the CCON register to generate an interrupt.

a. User software should not write 1s to reserved bits. These bits may be used in future 8051 family products to invoke new features. In that case, the reset or inactive value of the new bit will be 0, and its active value will be 1. The value read from a reserved bit is indeterminate.

Table 11. PCA Module Modes (CCAPMn Registers)

ECOMn	CAPPn	CAPNn	MATn	TOGn	PWMm	ECCFn	Module Function
0	0	0	0	0	0	0	No Operation
X	1	0	0	0	0	X	16-bit capture by a positive-edge trigger on CEXn
X	0	1	0	0	0	X	16-bit capture by a negative trigger on CEXn
X	1	1	0	0	0	X	16-bit capture by a transition on CEXn
1	0	0	1	0	0	X	16-bit Software Timer / Compare mode.
1	0	0	1	1	0	X	16-bit High Speed Output
1	0	0	0	0	1	0	8-bit PWM
1	0	0	1	X	0	X	Watchdog Timer (module 4 only)

There are two additional registers associated with each of the PCA modules. They are CCAPnH and CCAPnL and these are the registers that store the 16-bit count when a capture occurs or a compare should occur. When a module is used in the PWM mode these registers are used to control the duty cycle of the output (See Table 12 & Table 13)

**Table 12. CCAPnH: PCA Modules Capture/Compare Registers High**

<b>CCAPnH Address</b> <b>n = 0 - 4</b>	<b>CCAP0H=0FAH</b> <b>CCAP1H=0FBH</b> <b>CCAP2H=0FCH</b> <b>CCAP3H=0FDH</b> <b>CCAP4H=0FEH</b>		<b>7</b>	<b>6</b>	<b>5</b>	<b>4</b>	<b>3</b>	<b>2</b>	<b>1</b>	<b>0</b>
Reset value		0	0	0	0	0	0	0	0	0

**Table 13. CCAPnL: PCA Modules Capture/Compare Registers Low**

<b>CCAPnL Address</b> <b>n = 0 - 4</b>	<b>CCAP0L=0EAH</b> <b>CCAP1L=0EBH</b> <b>CCAP2L=0ECH</b> <b>CCAP3L=0EDH</b> <b>CCAP4L=0EEH</b>		<b>7</b>	<b>6</b>	<b>5</b>	<b>4</b>	<b>3</b>	<b>2</b>	<b>1</b>	<b>0</b>
Reset value		0	0	0	0	0	0	0	0	0

**Table 14. CH: PCA Counter High**

<b>CH</b> <b>Address 0F9H</b>		<b>7</b>	<b>6</b>	<b>5</b>	<b>4</b>	<b>3</b>	<b>2</b>	<b>1</b>	<b>0</b>
Reset value		0	0	0	0	0	0	0	0

**Table 15. CL: PCA Counter Low**

<b>CL</b> <b>Address 0E9H</b>		<b>7</b>	<b>6</b>	<b>5</b>	<b>4</b>	<b>3</b>	<b>2</b>	<b>1</b>	<b>0</b>
Reset value		0	0	0	0	0	0	0	0

### 6.5.1. PCA Capture Mode

To use one of the PCA modules in the capture mode either one or both of the CCAPM bits CAPN and CAPP for that module must be set. The external CEX input for the module (on port 1) is sampled for a transition. When a valid transition occurs the PCA hardware loads the value of the PCA counter registers (CH and CL) into the module's capture registers (CCAPnL and CCAPnH). If the CCFn bit for the module in the CCON SFR and the ECCFn bit in the CCAPMn SFR are set then an interrupt will be generated (Refer to Figure 9).

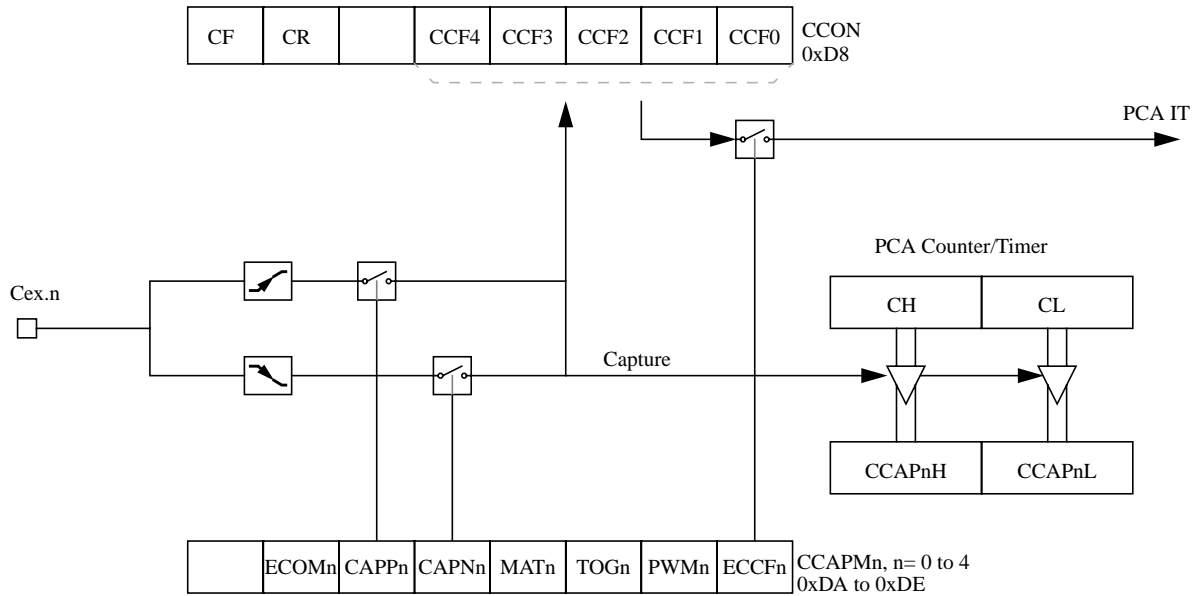

**Figure 9. PCA Capture Mode**

### 6.5.2. 16-bit Software Timer / Compare Mode

The PCA modules can be used as software timers by setting both the ECOM and MAT bits in the modules CCAPMn register. The PCA timer will be compared to the module's capture registers and when a match occurs an interrupt will occur if the CCFn (CCON SFR) and the ECCFn (CCAPMn SFR) bits for the module are both set (See Figure 10).

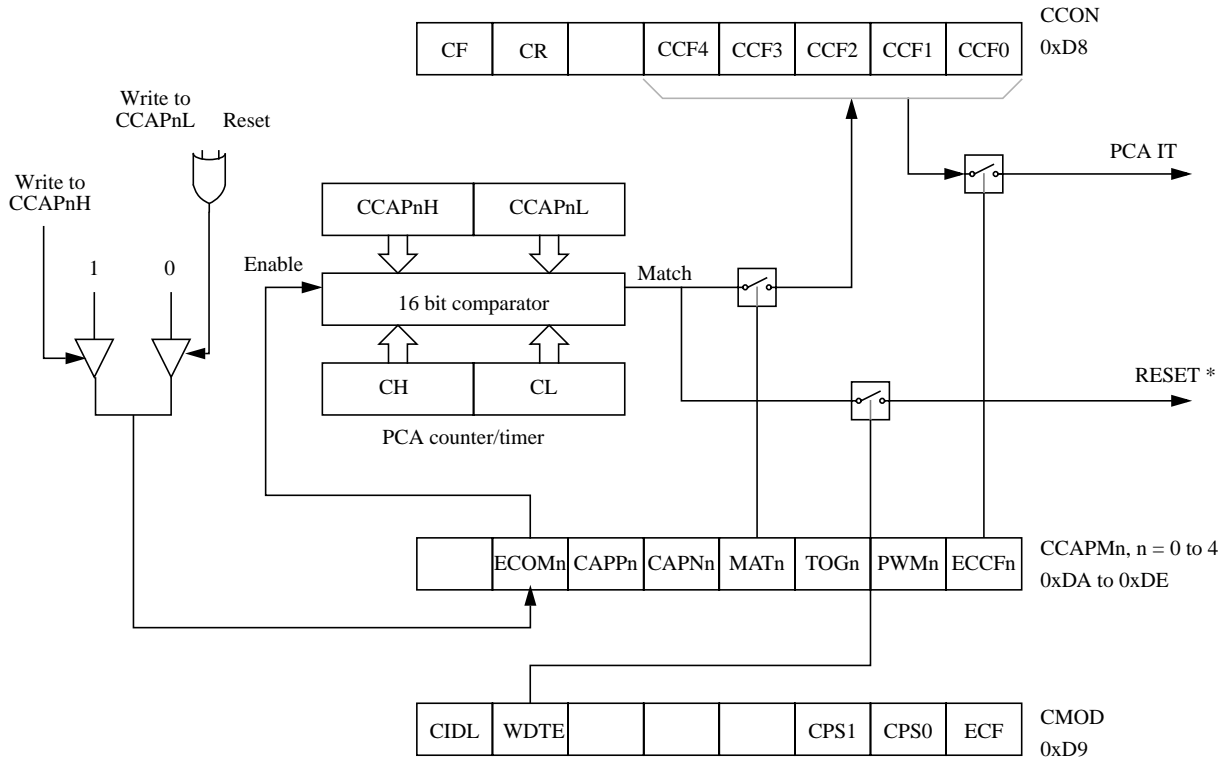

\* Only for Module 4

**Figure 10. PCA Compare Mode and PCA Watchdog Timer**

Before enabling ECOM bit, CCAPnL and CCAPnH should be set with a non zero value, otherwise an unwanted match could happen. Writing to CCAPnH will set the ECOM bit.

Once ECOM set, writing CCAPnL will clear ECOM so that an unwanted match doesn't occur while modifying the compare value. Writing to CCAPnH will set ECOM. For this reason, user software should write CCAPnL first, and then CCAPnH. Of course, the ECOM bit can still be controlled by accessing to CCAPMn register.

### 6.5.3. High Speed Output Mode

In this mode the CEX output (on port 1) associated with the PCA module will toggle each time a match occurs between the PCA counter and the module's capture registers. To activate this mode the TOG, MAT, and ECOM bits in the module's CCAPMn SFR must be set (See Figure 11).

A prior write must be done to CCAPnL and CCAPnH before writing the ECOMn bit.

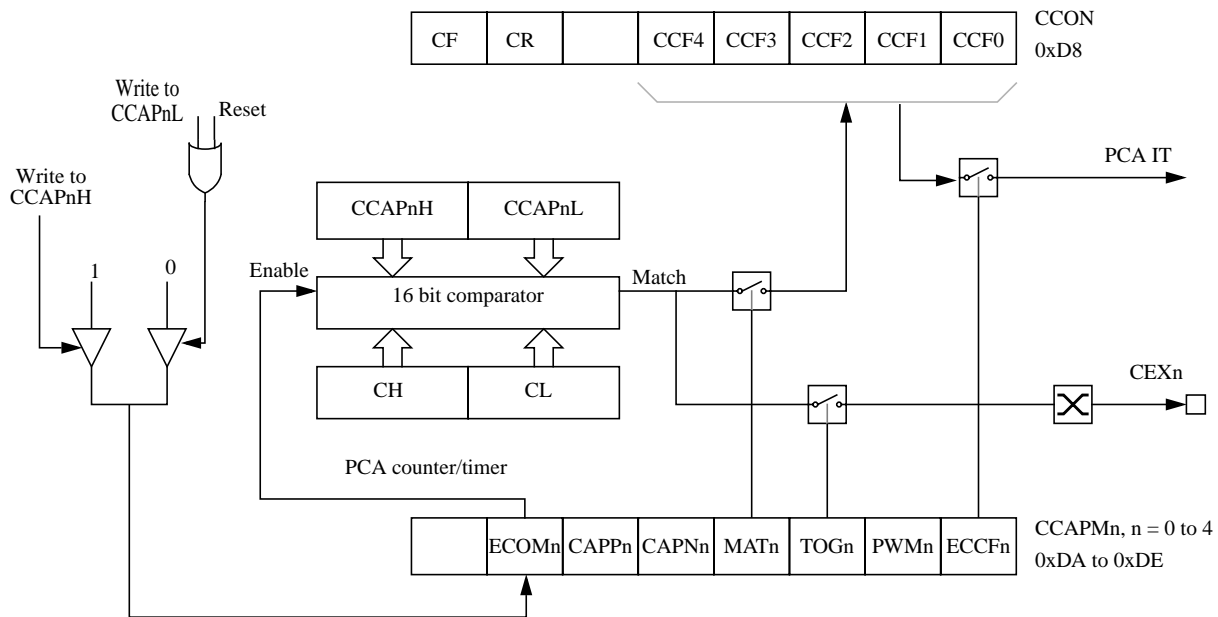

Figure 11. PCA High Speed Output Mode

Before enabling ECOM bit, CCAPnL and CCAPnH should be set with a non zero value, otherwise an unwanted match could happen.

Once ECOM set, writing CCAPnL will clear ECOM so that an unwanted match doesn't occur while modifying the compare value. Writing to CCAPnH will set ECOM. For this reason, user software should write CCAPnL first, and then CCAPnH. Of course, the ECOM bit can still be controlled by accessing to CCAPMn register.



### 6.5.4. Pulse Width Modulator Mode

All of the PCA modules can be used as PWM outputs. Figure 12 shows the PWM function. The frequency of the output depends on the source for the PCA timer. All of the modules will have the same frequency of output because they all share the PCA timer. The duty cycle of each module is independently variable using the module's capture register CCAPLn. When the value of the PCA CL SFR is less than the value in the module's CCAPLn SFR the output will be low, when it is equal to or greater than the output will be high. When CL overflows from FF to 00, CCAPLn is reloaded with the value in CCAPHn. This allows updating the PWM without glitches. The PWM and ECOM bits in the module's CCAPMn register must be set to enable the PWM mode.

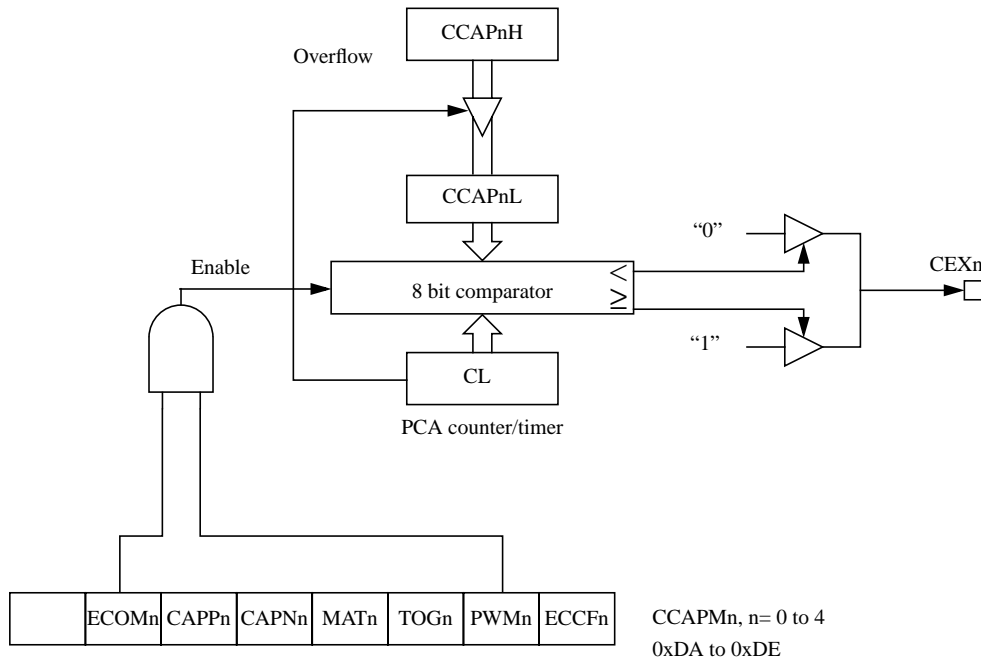

Figure 12. PCA PWM Mode

### 6.5.5. PCA Watchdog Timer

An on-board watchdog timer is available with the PCA to improve the reliability of the system without increasing chip count. Watchdog timers are useful for systems that are susceptible to noise, power glitches, or electrostatic discharge. Module 4 is the only PCA module that can be programmed as a watchdog. However, this module can still be used for other modes if the watchdog is not needed. Figure 10 shows a diagram of how the watchdog works. The user pre-loads a 16-bit value in the compare registers. Just like the other compare modes, this 16-bit value is compared to the PCA timer value. If a match is allowed to occur, an internal reset will be generated. This will not cause the RST pin to be driven high.

In order to hold off the reset, the user has three options:

- 1. periodically change the compare value so it will never match the PCA timer,
- 2. periodically change the PCA timer value so it will never match the compare values, or
- 3. disable the watchdog by clearing the WDTE bit before a match occurs and then re-enable it.

The first two options are more reliable because the watchdog timer is never disabled as in option #3. If the program counter ever goes astray, a match will eventually occur and cause an internal reset. The second option is also not recommended if other PCA modules are being used. Remember, the PCA timer is the time base for all modules; changing the time base for other modules would not be a good idea. Thus, in most applications the first solution is the best option.

This watchdog timer won't generate a reset out on the reset pin.

## 6.6. TS80C51Rx2 Serial I/O Port

The serial I/O port in the TS80C51Rx2 is compatible with the serial I/O port in the 80C52.

It provides both synchronous and asynchronous communication modes. It operates as an Universal Asynchronous Receiver and Transmitter (UART) in three full-duplex modes (Modes 1, 2 and 3). Asynchronous transmission and reception can occur simultaneously and at different baud rates

Serial I/O port includes the following enhancements:

- Framing error detection
- Automatic address recognition

### 6.6.1. Framing Error Detection

Framing bit error detection is provided for the three asynchronous modes (modes 1, 2 and 3). To enable the framing bit error detection feature, set SMOD0 bit in PCON register (See Figure 13).

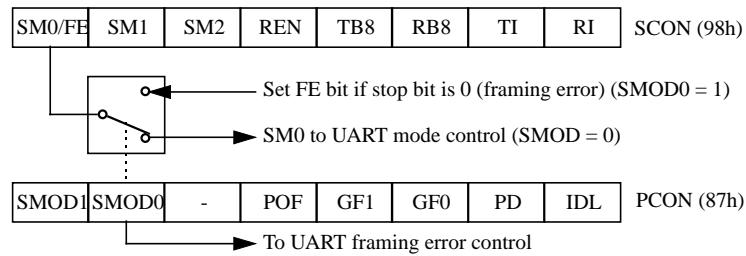

**Figure 13. Framing Error Block Diagram**

When this feature is enabled, the receiver checks each incoming data frame for a valid stop bit. An invalid stop bit may result from noise on the serial lines or from simultaneous transmission by two CPUs. If a valid stop bit is not found, the Framing Error bit (FE) in SCON register (See Table 16.) bit is set.

Software may examine FE bit after each reception to check for data errors. Once set, only software or a reset can clear FE bit. Subsequently received frames with valid stop bits cannot clear FE bit. When FE feature is enabled, RI rises on stop bit instead of the last data bit (See Figure 14. and Figure 15.).

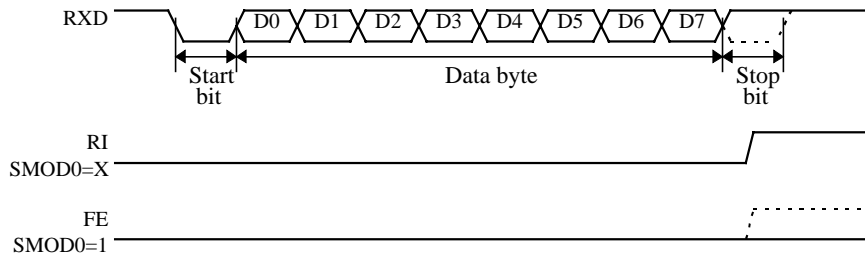

**Figure 14. UART Timings in Mode 1**

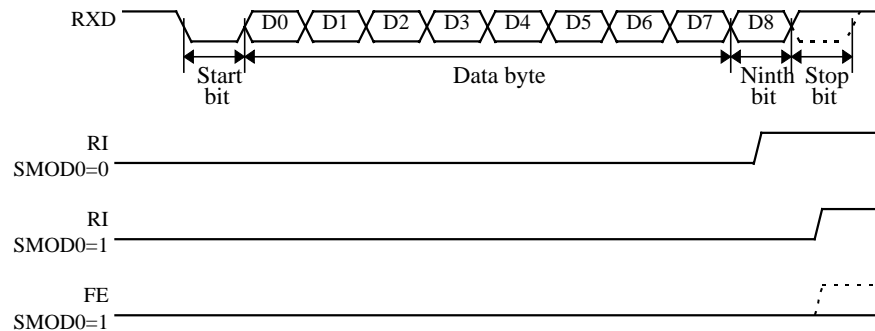

**Figure 15. UART Timings in Modes 2 and 3**

### 6.6.2. Automatic Address Recognition

The automatic address recognition feature is enabled when the multiprocessor communication feature is enabled (SM2 bit in SCON register is set).

Implemented in hardware, automatic address recognition enhances the multiprocessor communication feature by allowing the serial port to examine the address of each incoming command frame. Only when the serial port recognizes its own address, the receiver sets RI bit in SCON register to generate an interrupt. This ensures that the CPU is not interrupted by command frames addressed to other devices.

If desired, you may enable the automatic address recognition feature in mode 1. In this configuration, the stop bit takes the place of the ninth data bit. Bit RI is set only when the received command frame address matches the device's address and is terminated by a valid stop bit.

To support automatic address recognition, a device is identified by a given address and a broadcast address.

*NOTE: The multiprocessor communication and automatic address recognition features cannot be enabled in mode 0 (i.e. setting SM2 bit in SCON register in mode 0 has no effect).*

### 6.6.3. Given Address

Each device has an individual address that is specified in SADDR register; the SADEN register is a mask byte that contains don't-care bits (defined by zeros) to form the device's given address. The don't-care bits provide the flexibility to address one or more slaves at a time. The following example illustrates how a given address is formed. To address a device by its individual address, the SADEN mask byte must be 1111 1111b.

For example:

SADDR	0101 0110b
<u>SADEN</u>	<u>1111 1100b</u>
Given	0101 01XXb

The following is an example of how to use given addresses to address different slaves:

Slave A:	SADDR	1111 0001b
	<u>SADEN</u>	<u>1111 1010b</u>
	Given	1111 0X0Xb

Slave B:	SADDR	1111 0011b
	<u>SADEN</u>	<u>1111 1001b</u>
	Given	1111 0XX1b

Slave C:	SADDR	1111 0010b
	<u>SADEN</u>	<u>1111 1101b</u>
	Given	1111 00X1b

The SADEN byte is selected so that each slave may be addressed separately.

For slave A, bit 0 (the LSB) is a don't-care bit; for slaves B and C, bit 0 is a 1. To communicate with slave A only, the master must send an address where bit 0 is clear (e.g. 1111 0000b).

For slave A, bit 1 is a 1; for slaves B and C, bit 1 is a don't care bit. To communicate with slaves B and C, but not slave A, the master must send an address with bits 0 and 1 both set (e.g. 1111 0011b).

To communicate with slaves A, B and C, the master must send an address with bit 0 set, bit 1 clear, and bit 2 clear (e.g. 1111 0001b).

### 6.6.4. Broadcast Address

A broadcast address is formed from the logical OR of the SADDR and SADEN registers with zeros defined as don't-care bits, e.g.:

	SADDR	0101 0110b
	<u>SADEN</u>	<u>1111 1100b</u>
Broadcast =SADDR OR SADEN		1111 111Xb

The use of don't-care bits provides flexibility in defining the broadcast address, however in most applications, a broadcast address is FFh. The following is an example of using broadcast addresses:

Slave A:	SADDR	1111 0001b
	<u>SADEN</u>	<u>1111 1010b</u>
	Broadcast	1111 1X11b,

Slave B:	SADDR	1111 0011b
	<u>SADEN</u>	<u>1111 1001b</u>
	Broadcast	1111 1X11B,

Slave C:	SADDR=	1111 0010b
	<u>SADEN</u>	<u>1111 1101b</u>
	Broadcast	1111 1111b

For slaves A and B, bit 2 is a don't care bit; for slave C, bit 2 is set. To communicate with all of the slaves, the master must send an address FFh. To communicate with slaves A and B, but not slave C, the master can send and address FBh.

### 6.6.5. Reset Addresses

On reset, the SADDR and SADEN registers are initialized to 00h, i.e. the given and broadcast addresses are XXXX XXXXb (all don't-care bits). This ensures that the serial port will reply to any address, and so, that it is backwards compatible with the 80C51 microcontrollers that do not support automatic address recognition.

#### SADEN - Slave Address Mask Register (B9h)

7	6	5	4	3	2	1	0

Reset Value = 0000 0000b

Not bit addressable

#### SADDR - Slave Address Register (A9h)

7	6	5	4	3	2	1	0

Reset Value = 0000 0000b

Not bit addressable

Table 16. SCON Register

SCON - Serial Control Register (98h)

7	6	5	4	3	2	1	0																									
FE/SM0	SM1	SM2	REN	TB8	RB8	TI	RI																									
Bit Number	Bit Mnemonic	Description																														
7	FE	<b>Framing Error bit (SMOD0=1)</b> Clear to reset the error state, not cleared by a valid stop bit. Set by hardware when an invalid stop bit is detected. SMOD0 must be set to enable access to the FE bit																														
	SM0	<b>Serial port Mode bit 0</b> Refer to SM1 for serial port mode selection. SMOD0 must be cleared to enable access to the SM0 bit																														
6	SM1	<b>Serial port Mode bit 1</b> <table border="1"> <thead> <tr> <th>SM0</th> <th>SM1</th> <th>Mode</th> <th>Description</th> <th>Baud Rate</th> </tr> </thead> <tbody> <tr> <td>0</td> <td>0</td> <td>0</td> <td>Shift Register</td> <td><math>F_{XTAL}/12</math> (/6 in X2 mode)</td> </tr> <tr> <td>0</td> <td>1</td> <td>1</td> <td>8-bit UART</td> <td>Variable</td> </tr> <tr> <td>1</td> <td>0</td> <td>2</td> <td>9-bit UART</td> <td><math>F_{XTAL}/64</math> or <math>F_{XTAL}/32</math> (/32, /16 in X2 mode)</td> </tr> <tr> <td>1</td> <td>1</td> <td>3</td> <td>9-bit UART</td> <td>Variable</td> </tr> </tbody> </table>						SM0	SM1	Mode	Description	Baud Rate	0	0	0	Shift Register	$F_{XTAL}/12$ (/6 in X2 mode)	0	1	1	8-bit UART	Variable	1	0	2	9-bit UART	$F_{XTAL}/64$ or $F_{XTAL}/32$ (/32, /16 in X2 mode)	1	1	3	9-bit UART	Variable
SM0	SM1	Mode	Description	Baud Rate																												
0	0	0	Shift Register	$F_{XTAL}/12$ (/6 in X2 mode)																												
0	1	1	8-bit UART	Variable																												
1	0	2	9-bit UART	$F_{XTAL}/64$ or $F_{XTAL}/32$ (/32, /16 in X2 mode)																												
1	1	3	9-bit UART	Variable																												
5	SM2	<b>Serial port Mode 2 bit / Multiprocessor Communication Enable bit</b> Clear to disable multiprocessor communication feature. Set to enable multiprocessor communication feature in mode 2 and 3, and eventually mode 1. This bit should be cleared in mode 0.																														
4	REN	<b>Reception Enable bit</b> Clear to disable serial reception. Set to enable serial reception.																														
3	TB8	<b>Transmitter Bit 8 / Ninth bit to transmit in modes 2 and 3.</b> Clear to transmit a logic 0 in the 9th bit. Set to transmit a logic 1 in the 9th bit.																														
2	RB8	<b>Receiver Bit 8 / Ninth bit received in modes 2 and 3</b> Cleared by hardware if 9th bit received is a logic 0. Set by hardware if 9th bit received is a logic 1. In mode 1, if SM2 = 0, RB8 is the received stop bit. In mode 0 RB8 is not used.																														
1	TI	<b>Transmit Interrupt flag</b> Clear to acknowledge interrupt. Set by hardware at the end of the 8th bit time in mode 0 or at the beginning of the stop bit in the other modes.																														
0	RI	<b>Receive Interrupt flag</b> Clear to acknowledge interrupt. Set by hardware at the end of the 8th bit time in mode 0, see Figure 14. and Figure 15. in the other modes.																														

Reset Value = 0000 0000b

Bit addressable

**Table 17. PCON Register**

**PCON - Power Control Register (87h)**

<b>7</b>	<b>6</b>	<b>5</b>	<b>4</b>	<b>3</b>	<b>2</b>	<b>1</b>	<b>0</b>
<b>SMOD1</b>	<b>SMOD0</b>	-	<b>POF</b>	<b>GF1</b>	<b>GF0</b>	<b>PD</b>	<b>IDL</b>

Bit Number	Bit Mnemonic	Description
7	SMOD1	<b>Serial port Mode bit 1</b> Set to select double baud rate in mode 1, 2 or 3.
6	SMOD0	<b>Serial port Mode bit 0</b> Clear to select SM0 bit in SCON register. Set to to select FE bit in SCON register.
5	-	<b>Reserved</b> The value read from this bit is indeterminate. Do not set this bit.
4	POF	<b>Power-Off Flag</b> Clear to recognize next reset type. Set by hardware when VCC rises from 0 to its nominal voltage. Can also be set by software.
3	GF1	<b>General purpose Flag</b> Cleared by user for general purpose usage. Set by user for general purpose usage.
2	GF0	<b>General purpose Flag</b> Cleared by user for general purpose usage. Set by user for general purpose usage.
1	PD	<b>Power-Down mode bit</b> Cleared by hardware when reset occurs. Set to enter power-down mode.
0	IDL	<b>Idle mode bit</b> Clear by hardware when interrupt or reset occurs. Set to enter idle mode.

Reset Value = 00X1 0000b

Not bit addressable

Power-off flag reset value will be 1 only after a power on (cold reset). A warm reset doesn't affect the value of this bit.

### 6.7. Interrupt System

The TS80C51Rx2 has a total of 7 interrupt vectors: two external interrupts ( $\overline{INT0}$  and  $\overline{INT1}$ ), three timer interrupts (timers 0, 1 and 2), the serial port interrupt and the PCA global interrupt. These interrupts are shown in Figure 16.

**WARNING:** Note that in the first version of RC devices, the PCA interrupt is in the lowest priority. Thus the order in  $\overline{INT0}$ , TF0,  $\overline{INT1}$ , TF1, RI or TI, TF2 or EXF2, PCA.

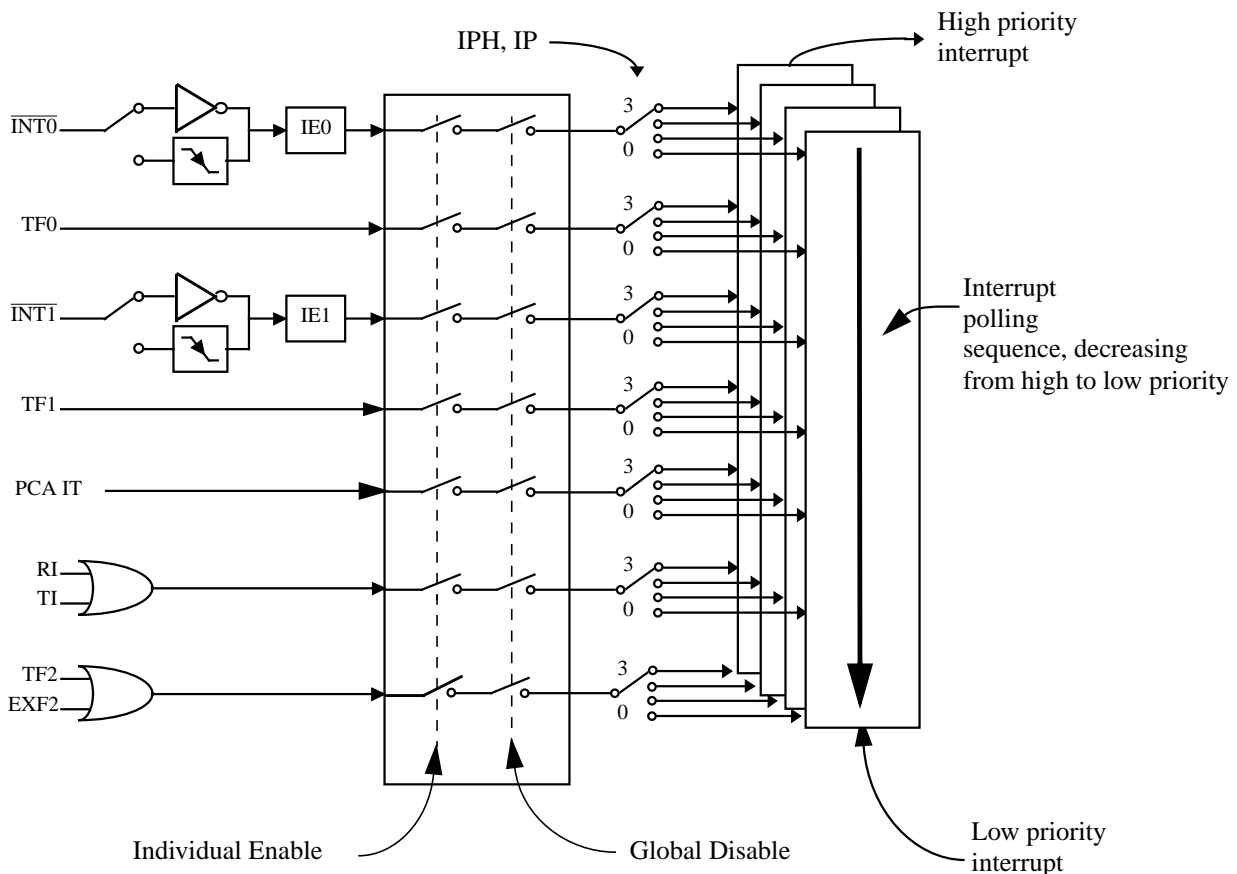

**Figure 16. Interrupt Control System**

Each of the interrupt sources can be individually enabled or disabled by setting or clearing a bit in the Interrupt Enable register (See Table 19.). This register also contains a global disable bit, which must be cleared to disable all interrupts at once.

Each interrupt source can also be individually programmed to one out of four priority levels by setting or clearing a bit in the Interrupt Priority register (See Table 20.) and in the Interrupt Priority High register (See Table 21.). shows the bit values and priority levels associated with each combination.

The PCA interrupt vector is located at address 0033H. All other vector addresses are the same as standard C52 devices.



**Table 18. Priority Level Bit Values**

IPH.x	IP.x	Interrupt Level Priority
0	0	0 (Lowest)
0	1	1
1	0	2
1	1	3 (Highest)

A low-priority interrupt can be interrupted by a high priority interrupt, but not by another low-priority interrupt. A high-priority interrupt can't be interrupted by any other interrupt source.

If two interrupt requests of different priority levels are received simultaneously, the request of higher priority level is serviced. If interrupt requests of the same priority level are received simultaneously, an internal polling sequence determines which request is serviced. Thus within each priority level there is a second priority structure determined by the polling sequence.

**Table 19. IE Register**

**IE - Interrupt Enable Register (A8h)**

7	6	5	4	3	2	1	0
<b>EA</b>	<b>EC</b>	<b>ET2</b>	<b>ES</b>	<b>ET1</b>	<b>EX1</b>	<b>ET0</b>	<b>EX0</b>

Bit Number	Bit Mnemonic	Description
7	EA	<b>Enable All interrupt bit</b> Clear to disable all interrupts. Set to enable all interrupts. If EA=1, each interrupt source is individually enabled or disabled by setting or clearing its own interrupt enable bit.
6	EC	<b>PCA interrupt enable bit</b> Clear to disable . Set to enable.
5	ET2	<b>Timer 2 overflow interrupt Enable bit</b> Clear to disable timer 2 overflow interrupt. Set to enable timer 2 overflow interrupt.
4	ES	<b>Serial port Enable bit</b> Clear to disable serial port interrupt. Set to enable serial port interrupt.
3	ET1	<b>Timer 1 overflow interrupt Enable bit</b> Clear to disable timer 1 overflow interrupt. Set to enable timer 1 overflow interrupt.
2	EX1	<b>External interrupt 1 Enable bit</b> Clear to disable external interrupt 1. Set to enable external interrupt 1.
1	ET0	<b>Timer 0 overflow interrupt Enable bit</b> Clear to disable timer 0 overflow interrupt. Set to enable timer 0 overflow interrupt.
0	EX0	<b>External interrupt 0 Enable bit</b> Clear to disable external interrupt 0. Set to enable external interrupt 0.

Reset Value = 0000 0000b

Bit addressable

Table 20. IP Register

IP - Interrupt Priority Register (B8h)

7	6	5	4	3	2	1	0
-	PPC	PT2	PS	PT1	PX1	PT0	PX0

Bit Number	Bit Mnemonic	Description
7	-	<b>Reserved</b> The value read from this bit is indeterminate. Do not set this bit.
6	PPC	<b>PCA interrupt priority bit</b> Refer to PPCH for priority level.
5	PT2	<b>Timer 2 overflow interrupt Priority bit</b> Refer to PT2H for priority level.
4	PS	<b>Serial port Priority bit</b> Refer to PSH for priority level.
3	PT1	<b>Timer 1 overflow interrupt Priority bit</b> Refer to PT1H for priority level.
2	PX1	<b>External interrupt 1 Priority bit</b> Refer to PX1H for priority level.
1	PT0	<b>Timer 0 overflow interrupt Priority bit</b> Refer to PT0H for priority level.
0	PX0	<b>External interrupt 0 Priority bit</b> Refer to PX0H for priority level.

Reset Value = X000 0000b

Bit addressable

**Table 21. IPH Register**

**IPH - Interrupt Priority High Register (B7h)**

7	6	5	4	3	2	1	0
-	PPCH	PT2H	PSH	PT1H	PX1H	PT0H	PX0H

Bit Number	Bit Mnemonic	Description															
7	-	<b>Reserved</b> The value read from this bit is indeterminate. Do not set this bit.															
6	PPCH	<b>PCA interrupt priority bit high.</b> <table style="width: 100%; border-collapse: collapse;"> <tr> <td style="text-align: center;"><u>PPCH</u></td> <td style="text-align: center;"><u>PPC</u></td> <td style="text-align: center;"><u>Priority Level</u></td> </tr> <tr> <td style="text-align: center;">0</td> <td style="text-align: center;">0</td> <td style="text-align: center;">Lowest</td> </tr> <tr> <td style="text-align: center;">0</td> <td style="text-align: center;">1</td> <td></td> </tr> <tr> <td style="text-align: center;">1</td> <td style="text-align: center;">0</td> <td></td> </tr> <tr> <td style="text-align: center;">1</td> <td style="text-align: center;">1</td> <td style="text-align: center;">Highest</td> </tr> </table>	<u>PPCH</u>	<u>PPC</u>	<u>Priority Level</u>	0	0	Lowest	0	1		1	0		1	1	Highest
<u>PPCH</u>	<u>PPC</u>	<u>Priority Level</u>															
0	0	Lowest															
0	1																
1	0																
1	1	Highest															
5	PT2H	<b>Timer 2 overflow interrupt Priority High bit</b> <table style="width: 100%; border-collapse: collapse;"> <tr> <td style="text-align: center;"><u>PT2H</u></td> <td style="text-align: center;"><u>PT2</u></td> <td style="text-align: center;"><u>Priority Level</u></td> </tr> <tr> <td style="text-align: center;">0</td> <td style="text-align: center;">0</td> <td style="text-align: center;">Lowest</td> </tr> <tr> <td style="text-align: center;">0</td> <td style="text-align: center;">1</td> <td></td> </tr> <tr> <td style="text-align: center;">1</td> <td style="text-align: center;">0</td> <td></td> </tr> <tr> <td style="text-align: center;">1</td> <td style="text-align: center;">1</td> <td style="text-align: center;">Highest</td> </tr> </table>	<u>PT2H</u>	<u>PT2</u>	<u>Priority Level</u>	0	0	Lowest	0	1		1	0		1	1	Highest
<u>PT2H</u>	<u>PT2</u>	<u>Priority Level</u>															
0	0	Lowest															
0	1																
1	0																
1	1	Highest															
4	PSH	<b>Serial port Priority High bit</b> <table style="width: 100%; border-collapse: collapse;"> <tr> <td style="text-align: center;"><u>PSH</u></td> <td style="text-align: center;"><u>PS</u></td> <td style="text-align: center;"><u>Priority Level</u></td> </tr> <tr> <td style="text-align: center;">0</td> <td style="text-align: center;">0</td> <td style="text-align: center;">Lowest</td> </tr> <tr> <td style="text-align: center;">0</td> <td style="text-align: center;">1</td> <td></td> </tr> <tr> <td style="text-align: center;">1</td> <td style="text-align: center;">0</td> <td></td> </tr> <tr> <td style="text-align: center;">1</td> <td style="text-align: center;">1</td> <td style="text-align: center;">Highest</td> </tr> </table>	<u>PSH</u>	<u>PS</u>	<u>Priority Level</u>	0	0	Lowest	0	1		1	0		1	1	Highest
<u>PSH</u>	<u>PS</u>	<u>Priority Level</u>															
0	0	Lowest															
0	1																
1	0																
1	1	Highest															
3	PT1H	<b>Timer 1 overflow interrupt Priority High bit</b> <table style="width: 100%; border-collapse: collapse;"> <tr> <td style="text-align: center;"><u>PT1H</u></td> <td style="text-align: center;"><u>PT1</u></td> <td style="text-align: center;"><u>Priority Level</u></td> </tr> <tr> <td style="text-align: center;">0</td> <td style="text-align: center;">0</td> <td style="text-align: center;">Lowest</td> </tr> <tr> <td style="text-align: center;">0</td> <td style="text-align: center;">1</td> <td></td> </tr> <tr> <td style="text-align: center;">1</td> <td style="text-align: center;">0</td> <td></td> </tr> <tr> <td style="text-align: center;">1</td> <td style="text-align: center;">1</td> <td style="text-align: center;">Highest</td> </tr> </table>	<u>PT1H</u>	<u>PT1</u>	<u>Priority Level</u>	0	0	Lowest	0	1		1	0		1	1	Highest
<u>PT1H</u>	<u>PT1</u>	<u>Priority Level</u>															
0	0	Lowest															
0	1																
1	0																
1	1	Highest															
2	PX1H	<b>External interrupt 1 Priority High bit</b> <table style="width: 100%; border-collapse: collapse;"> <tr> <td style="text-align: center;"><u>PX1H</u></td> <td style="text-align: center;"><u>PX1</u></td> <td style="text-align: center;"><u>Priority Level</u></td> </tr> <tr> <td style="text-align: center;">0</td> <td style="text-align: center;">0</td> <td style="text-align: center;">Lowest</td> </tr> <tr> <td style="text-align: center;">0</td> <td style="text-align: center;">1</td> <td></td> </tr> <tr> <td style="text-align: center;">1</td> <td style="text-align: center;">0</td> <td></td> </tr> <tr> <td style="text-align: center;">1</td> <td style="text-align: center;">1</td> <td style="text-align: center;">Highest</td> </tr> </table>	<u>PX1H</u>	<u>PX1</u>	<u>Priority Level</u>	0	0	Lowest	0	1		1	0		1	1	Highest
<u>PX1H</u>	<u>PX1</u>	<u>Priority Level</u>															
0	0	Lowest															
0	1																
1	0																
1	1	Highest															
1	PT0H	<b>Timer 0 overflow interrupt Priority High bit</b> <table style="width: 100%; border-collapse: collapse;"> <tr> <td style="text-align: center;"><u>PT0H</u></td> <td style="text-align: center;"><u>PT0</u></td> <td style="text-align: center;"><u>Priority Level</u></td> </tr> <tr> <td style="text-align: center;">0</td> <td style="text-align: center;">0</td> <td style="text-align: center;">Lowest</td> </tr> <tr> <td style="text-align: center;">0</td> <td style="text-align: center;">1</td> <td></td> </tr> <tr> <td style="text-align: center;">1</td> <td style="text-align: center;">0</td> <td></td> </tr> <tr> <td style="text-align: center;">1</td> <td style="text-align: center;">1</td> <td style="text-align: center;">Highest</td> </tr> </table>	<u>PT0H</u>	<u>PT0</u>	<u>Priority Level</u>	0	0	Lowest	0	1		1	0		1	1	Highest
<u>PT0H</u>	<u>PT0</u>	<u>Priority Level</u>															
0	0	Lowest															
0	1																
1	0																
1	1	Highest															
0	PX0H	<b>External interrupt 0 Priority High bit</b> <table style="width: 100%; border-collapse: collapse;"> <tr> <td style="text-align: center;"><u>PX0H</u></td> <td style="text-align: center;"><u>PX0</u></td> <td style="text-align: center;"><u>Priority Level</u></td> </tr> <tr> <td style="text-align: center;">0</td> <td style="text-align: center;">0</td> <td style="text-align: center;">Lowest</td> </tr> <tr> <td style="text-align: center;">0</td> <td style="text-align: center;">1</td> <td></td> </tr> <tr> <td style="text-align: center;">1</td> <td style="text-align: center;">0</td> <td></td> </tr> <tr> <td style="text-align: center;">1</td> <td style="text-align: center;">1</td> <td style="text-align: center;">Highest</td> </tr> </table>	<u>PX0H</u>	<u>PX0</u>	<u>Priority Level</u>	0	0	Lowest	0	1		1	0		1	1	Highest
<u>PX0H</u>	<u>PX0</u>	<u>Priority Level</u>															
0	0	Lowest															
0	1																
1	0																
1	1	Highest															

Reset Value = X000 0000b

Not bit addressable

## 6.8. Idle mode

An instruction that sets PCON.0 causes that to be the last instruction executed before going into the Idle mode. In the Idle mode, the internal clock signal is gated off to the CPU, but not to the interrupt, Timer, and Serial Port functions. The CPU status is preserved in its entirety : the Stack Pointer, Program Counter, Program Status Word, Accumulator and all other registers maintain their data during Idle. The port pins hold the logical states they had at the time Idle was activated. ALE and PSEN hold at logic high levels.

There are two ways to terminate the Idle. Activation of any enabled interrupt will cause PCON.0 to be cleared by hardware, terminating the Idle mode. The interrupt will be serviced, and following RETI the next instruction to be executed will be the one following the instruction that put the device into idle.

The flag bits GF0 and GF1 can be used to give an indication if an interrupt occurred during normal operation or during an Idle. For example, an instruction that activates Idle can also set one or both flag bits. When Idle is terminated by an interrupt, the interrupt service routine can examine the flag bits.

The other way of terminating the Idle mode is with a hardware reset. Since the clock oscillator is still running, the hardware reset needs to be held active for only two machine cycles (24 oscillator periods) to complete the reset.

## 6.9. Power-Down Mode

To save maximum power, a power-down mode can be invoked by software (Refer to Table 17., PCON register).

In power-down mode, the oscillator is stopped and the instruction that invoked power-down mode is the last instruction executed. The internal RAM and SFRs retain their value until the power-down mode is terminated.  $V_{CC}$  can be lowered to save further power. Either a hardware reset or an external interrupt can cause an exit from power-down. To properly terminate power-down, the reset or external interrupt should not be executed before  $V_{CC}$  is restored to its normal operating level and must be held active long enough for the oscillator to restart and stabilize.

Only external interrupts  $\overline{INT0}$  and  $\overline{INT1}$  are useful to exit from power-down. For that, interrupt must be enabled and configured as level or edge sensitive interrupt input.

Holding the pin low restarts the oscillator but bringing the pin high completes the exit as detailed in Figure 17. When both interrupts are enabled, the oscillator restarts as soon as one of the two inputs is held low and power down exit will be completed when the first input will be released. In this case the higher priority interrupt service routine is executed.

Once the interrupt is serviced, the next instruction to be executed after RETI will be the one following the instruction that put TS80C51Rx2 into power-down mode.

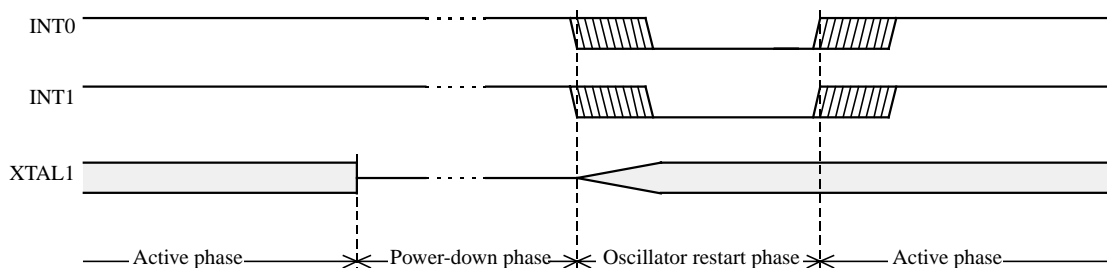

**Figure 17. Power-Down Exit Waveform**

Exit from power-down by reset redefines all the SFRs, exit from power-down by external interrupt does no affect the SFRs.

Exit from power-down by either reset or external interrupt does not affect the internal RAM content.

*NOTE: If idle mode is activated with power-down mode (IDL and PD bits set), the exit sequence is unchanged, when execution is vectored to interrupt, PD and IDL bits are cleared and idle mode is not entered.*

**Table 22. The state of ports during idle and power-down mode**

Mode	Program Memory	ALE	$\overline{\text{PSEN}}$	PORT0	PORT1	PORT2	PORT3
Idle	Internal	1	1	Port Data*	Port Data	Port Data	Port Data
Idle	External	1	1	Floating	Port Data	Address	Port Data
Power Down	Internal	0	0	Port Data*	Port Data	Port Data	Port Data
Power Down	External	0	0	Floating	Port Data	Port Data	Port Data

\* Port 0 can force a "zero" level. A "one" will leave port floating.

## 6.10. Hardware Watchdog Timer

The WDT is intended as a recovery method in situations where the CPU may be subjected to software upset. The WDT consists of a 14-bit counter and the WatchDog Timer ReSeT (WDTRST) SFR. The WDT is by default disabled from exiting reset. To enable the WDT, user must write 01EH and 0E1H in sequence to the WDTRST, SFR location 0A6H. When WDT is enabled, it will increment every machine cycle while the oscillator is running and there is no way to disable the WDT except through reset (either hardware reset or WDT overflow reset). When WDT overflows, it will drive an output RESET HIGH pulse at the RST-pin.

### 6.10.1. Using the WDT

To enable the WDT, user must write 01EH and 0E1H in sequence to the WDTRST, SFR location 0A6H. When WDT is enabled, the user needs to service it by writing to 01EH and 0E1H to WDTRST to avoid WDT overflow. The 14-bit counter overflows when it reaches 16383 (3FFFH) and this will reset the device. When WDT is enabled, it will increment every machine cycle while the oscillator is running. This means the user must reset the WDT at least every 16383 machine cycle. To reset the WDT the user must write 01EH and 0E1H to WDTRST. WDTRST is a write only register. The WDT counter cannot be read or written. When WDT overflows, it will generate an output RESET pulse at the RST-pin. The RESET pulse duration is  $96 \times T_{OSC}$ , where  $T_{OSC} = 1/F_{OSC}$ . To make the best use of the WDT, it should be serviced in those sections of code that will periodically be executed within the time required to prevent a WDT reset.

To have a more powerful WDT, a  $2^7$  counter has been added to extend the Time-out capability, ranking from 16ms to 2s @  $F_{OSC} = 12\text{MHz}$ . To manage this feature, refer to WDTPRG register description, Table 24. (SFR0A7h).

**Table 23. WDTRST Register**

**WDTRST Address (0A6h)**

	7	6	5	4	3	2	1
Reset value	X	X	X	X	X	X	X

Write only, this SFR is used to reset/enable the WDT by writing 01EH then 0E1H in sequence.

**Table 24. WDTPRG Register**

WDTPRG Address (0A7h)

<b>7</b>	<b>6</b>	<b>5</b>	<b>4</b>	<b>3</b>	<b>2</b>	<b>1</b>	<b>0</b>
<b>T4</b>	<b>T3</b>	<b>T2</b>	<b>T1</b>	<b>T0</b>	<b>S2</b>	<b>S1</b>	<b>S0</b>

Bit Number	Bit Mnemonic	Description																																				
7	T4	<b>Reserved</b> Do not try to set or clear this bit.																																				
6	T3																																					
5	T2																																					
4	T1																																					
3	T0																																					
2	S2	<b>WDT Time-out select bit 2</b>																																				
1	S1	<b>WDT Time-out select bit 1</b>																																				
0	S0	<b>WDT Time-out select bit 0</b>																																				
		<table style="width: 100%; border-collapse: collapse;"> <thead> <tr> <th style="width: 10%;"><u>S2</u></th> <th style="width: 10%;"><u>S1</u></th> <th style="width: 10%;"><u>S0</u></th> <th style="width: 70%;"><u>Selected Time-out</u></th> </tr> </thead> <tbody> <tr> <td>0</td> <td>0</td> <td>0</td> <td>(2<sup>14</sup> - 1) machine cycles, 16.3 ms @ 12 MHz</td> </tr> <tr> <td>0</td> <td>0</td> <td>1</td> <td>(2<sup>15</sup> - 1) machine cycles, 32.7 ms @ 12 MHz</td> </tr> <tr> <td>0</td> <td>1</td> <td>0</td> <td>(2<sup>16</sup> - 1) machine cycles, 65.5 ms @ 12 MHz</td> </tr> <tr> <td>0</td> <td>1</td> <td>1</td> <td>(2<sup>17</sup> - 1) machine cycles, 131 ms @ 12 MHz</td> </tr> <tr> <td>1</td> <td>0</td> <td>0</td> <td>(2<sup>18</sup> - 1) machine cycles, 262 ms @ 12 MHz</td> </tr> <tr> <td>1</td> <td>0</td> <td>1</td> <td>(2<sup>19</sup> - 1) machine cycles, 542 ms @ 12 MHz</td> </tr> <tr> <td>1</td> <td>1</td> <td>0</td> <td>(2<sup>20</sup> - 1) machine cycles, 1.05 s @ 12 MHz</td> </tr> <tr> <td>1</td> <td>1</td> <td>1</td> <td>(2<sup>21</sup> - 1) machine cycles, 2.09 s @ 12 MHz</td> </tr> </tbody> </table>	<u>S2</u>	<u>S1</u>	<u>S0</u>	<u>Selected Time-out</u>	0	0	0	(2 <sup>14</sup> - 1) machine cycles, 16.3 ms @ 12 MHz	0	0	1	(2 <sup>15</sup> - 1) machine cycles, 32.7 ms @ 12 MHz	0	1	0	(2 <sup>16</sup> - 1) machine cycles, 65.5 ms @ 12 MHz	0	1	1	(2 <sup>17</sup> - 1) machine cycles, 131 ms @ 12 MHz	1	0	0	(2 <sup>18</sup> - 1) machine cycles, 262 ms @ 12 MHz	1	0	1	(2 <sup>19</sup> - 1) machine cycles, 542 ms @ 12 MHz	1	1	0	(2 <sup>20</sup> - 1) machine cycles, 1.05 s @ 12 MHz	1	1	1	(2 <sup>21</sup> - 1) machine cycles, 2.09 s @ 12 MHz
<u>S2</u>	<u>S1</u>	<u>S0</u>	<u>Selected Time-out</u>																																			
0	0	0	(2 <sup>14</sup> - 1) machine cycles, 16.3 ms @ 12 MHz																																			
0	0	1	(2 <sup>15</sup> - 1) machine cycles, 32.7 ms @ 12 MHz																																			
0	1	0	(2 <sup>16</sup> - 1) machine cycles, 65.5 ms @ 12 MHz																																			
0	1	1	(2 <sup>17</sup> - 1) machine cycles, 131 ms @ 12 MHz																																			
1	0	0	(2 <sup>18</sup> - 1) machine cycles, 262 ms @ 12 MHz																																			
1	0	1	(2 <sup>19</sup> - 1) machine cycles, 542 ms @ 12 MHz																																			
1	1	0	(2 <sup>20</sup> - 1) machine cycles, 1.05 s @ 12 MHz																																			
1	1	1	(2 <sup>21</sup> - 1) machine cycles, 2.09 s @ 12 MHz																																			

Reset value XXXX X000

### 6.10.2. WDT during Power Down and Idle

In Power Down mode the oscillator stops, which means the WDT also stops. While in Power Down mode the user does not need to service the WDT. There are 2 methods of exiting Power Down mode: by a hardware reset or via a level activated external interrupt which is enabled prior to entering Power Down mode. When Power Down is exited with hardware reset, servicing the WDT should occur as it normally should whenever the TS80C51Rx2 is reset. Exiting Power Down with an interrupt is significantly different. The interrupt is held low long enough for the oscillator to stabilize. When the interrupt is brought high, the interrupt is serviced. To prevent the WDT from resetting the device while the interrupt pin is held low, the WDT is not started until the interrupt is pulled high. It is suggested that the WDT be reset during the interrupt service routine.

To ensure that the WDT does not overflow within a few states of exiting of powerdown, it is best to reset the WDT just before entering powerdown.

In the Idle mode, the oscillator continues to run. To prevent the WDT from resetting the TS80C51Rx2 while in Idle mode, the user should always set up a timer that will periodically exit Idle, service the WDT, and re-enter Idle mode.

### 6.11. ONCE™ Mode (ON Chip Emulation)

The ONCE mode facilitates testing and debugging of systems using TS80C51Rx2 without removing the circuit from the board. The ONCE mode is invoked by driving certain pins of the TS80C51Rx2; the following sequence must be exercised:

- Pull ALE low while the device is in reset (RST high) and  $\overline{\text{PSEN}}$  is high.
- Hold ALE low as RST is deactivated.

While the TS80C51Rx2 is in ONCE mode, an emulator or test CPU can be used to drive the circuit Table 26. shows the status of the port pins during ONCE mode.

Normal operation is restored when normal reset is applied.

**Table 25. External Pin Status during ONCE Mode**

ALE	PSEN	Port 0	Port 1	Port 2	Port 3	XTAL1/2
Weak pull-up	Weak pull-up	Float	Weak pull-up	Weak pull-up	Weak pull-up	Active



## 6.12. Power-Off Flag

The power-off flag allows the user to distinguish between a “cold start” reset and a “warm start” reset.

A cold start reset is the one induced by  $V_{CC}$  switch-on. A warm start reset occurs while  $V_{CC}$  is still applied to the device and could be generated for example by an exit from power-down.

The power-off flag (POF) is located in PCON register (See Table 26.). POF is set by hardware when  $V_{CC}$  rises from 0 to its nominal voltage. The POF can be set or cleared by software allowing the user to determine the type of reset.

The POF value is only relevant with a  $V_{CC}$  range from 4.5V to 5.5V. For lower  $V_{CC}$  value, reading POF bit will return indeterminate value.

**Table 26. PCON Register**

**PCON - Power Control Register (87h)**

<b>7</b>	<b>6</b>	<b>5</b>	<b>4</b>	<b>3</b>	<b>2</b>	<b>1</b>	<b>0</b>
<b>SMOD1</b>	<b>SMOD0</b>	<b>-</b>	<b>POF</b>	<b>GF1</b>	<b>GF0</b>	<b>PD</b>	<b>IDL</b>

Bit Number	Bit Mnemonic	Description
7	SMOD1	<b>Serial port Mode bit 1</b> Set to select double baud rate in mode 1, 2 or 3.
6	SMOD0	<b>Serial port Mode bit 0</b> Clear to select SM0 bit in SCON register. Set to to select FE bit in SCON register.
5	-	<b>Reserved</b> The value read from this bit is indeterminate. Do not set this bit.
4	POF	<b>Power-Off Flag</b> Clear to recognize next reset type. Set by hardware when $V_{CC}$ rises from 0 to its nominal voltage. Can also be set by software.
3	GF1	<b>General purpose Flag</b> Cleared by user for general purpose usage. Set by user for general purpose usage.
2	GF0	<b>General purpose Flag</b> Cleared by user for general purpose usage. Set by user for general purpose usage.
1	PD	<b>Power-Down mode bit</b> Cleared by hardware when reset occurs. Set to enter power-down mode.
0	IDL	<b>Idle mode bit</b> Clear by hardware when interrupt or reset occurs. Set to enter idle mode.

Reset Value = 00X1 0000b

Not bit addressable

### 6.13. Reduced EMI Mode

The ALE signal is used to demultiplex address and data buses on port 0 when used with external program or data memory. Nevertheless, during internal code execution, ALE signal is still generated. In order to reduce EMI, ALE signal can be disabled by setting AO bit.

The AO bit is located in AUXR register at bit location 0. As soon as AO is set, ALE is no longer output but remains active during MOVX and MOVC instructions and external fetches. During ALE disabling, ALE pin is weakly pulled high.

**Table 27. AUXR Register**

**AUXR - Auxiliary Register (8Eh)**

<b>7</b>	<b>6</b>	<b>5</b>	<b>4</b>	<b>3</b>	<b>2</b>	<b>1</b>	<b>0</b>
-	-	-	-	-	-	EXTRAM	AO

Bit Number	Bit Mnemonic	Description
7	-	<b>Reserved</b> The value read from this bit is indeterminate. Do not set this bit.
6	-	<b>Reserved</b> The value read from this bit is indeterminate. Do not set this bit.
5	-	<b>Reserved</b> The value read from this bit is indeterminate. Do not set this bit.
4	-	<b>Reserved</b> The value read from this bit is indeterminate. Do not set this bit.
3	-	<b>Reserved</b> The value read from this bit is indeterminate. Do not set this bit.
2	-	<b>Reserved</b> The value read from this bit is indeterminate. Do not set this bit.
1	EXTRAM	<b>EXTRAM bit</b> See Table 5.
0	AO	<b>ALE Output bit</b> Clear to restore ALE operation during internal fetches. Set to disable ALE operation during internal fetches.

Reset Value = XXXX XX00b

Not bit addressable

## 7. TS83C51RB2/RC2/RD2 ROM

### 7.1. ROM Structure

The TS83C51RB2/RC2/RD2 ROM memory is divided in three different arrays:

- the code array: . . . . . 16/32/64 Kbytes.
- the encryption array: . . . . . 64 bytes.
- the signature array: . . . . . 4 bytes.

### 7.2. ROM Lock System

The program Lock system, when programmed, protects the on-chip program against software piracy.

#### 7.2.1. 7.2.1. Encryption Array

Within the ROM array are 64 bytes of encryption array that are initially unprogrammed (all FF's). Every time a byte is addressed during program verify, 6 address lines are used to select a byte of the encryption array. This byte is then exclusive-NOR'ed (XNOR) with the code byte, creating an encrypted verify byte. The algorithm, with the encryption array in the unprogrammed state, will return the code in its original, unmodified form.

When using the encryption array, one important factor needs to be considered. If a byte has the value FFh, verifying the byte will produce the encryption byte value. If a large block (>64 bytes) of code is left unprogrammed, a verification routine will display the content of the encryption array. For this reason all the unused code bytes should be programmed with random values. This will ensure program protection.

#### 7.2.2. Program Lock Bits

The lock bits when programmed according to Table 28. will provide different level of protection for the on-chip code and data.

**Table 28. Program Lock bits**

Program Lock Bits				Protection description
Security level	LB1	LB2	LB3	
1	U	U	U	No program lock features enabled. Code verify will still be encrypted by the encryption array if programmed. MOVC instruction executed from external program memory returns non encrypted data.
2	P	U	U	MOVC instruction executed from external program memory are disabled from fetching code bytes from internal memory, EA is sampled and latched on reset.
3	U	P	U	Same as level 1+ Verify disable. This security level is only available for 51RDX2 devices.

U: unprogrammed

P: programmed

#### 7.2.3. Signature bytes

The TS83C51RB2/RC2/RD2 contains 4 factory programmed signatures bytes. To read these bytes, perform the process described in section 8.3.

#### 7.2.4. Verify Algorithm

Refer to 8.3.4.

## 8. TS87C51RB2/RC2/RD2 EPROM

### 8.1. EPROM Structure

The TS87C51RB2/RC2/RD2 EPROM is divided in two different arrays:

- the code array: . . . . . 16/32/64 Kbytes.
- the encryption array: . . . . . 64 bytes.

In addition a third non programmable array is implemented:

- the signature array: . . . . . 4 bytes.

### 8.2. EPROM Lock System

The program Lock system, when programmed, protects the on-chip program against software piracy.

#### 8.2.1. Encryption Array

Within the EPROM array are 64 bytes of encryption array that are initially unprogrammed (all FF's). Every time a byte is addressed during program verify, 6 address lines are used to select a byte of the encryption array. This byte is then exclusive-NOR'ed (XNOR) with the code byte, creating an encrypted verify byte. The algorithm, with the encryption array in the unprogrammed state, will return the code in its original, unmodified form.

When using the encryption array, one important factor needs to be considered. If a byte has the value FFh, verifying the byte will produce the encryption byte value. If a large block (>64 bytes) of code is left unprogrammed, a verification routine will display the content of the encryption array. For this reason all the unused code bytes should be programmed with random values. This will ensure program protection.

#### 8.2.2. Program Lock Bits

The three lock bits, when programmed according to Table 29.8.2.3. , will provide different level of protection for the on-chip code and data.

**Table 29. Program Lock bits**

Program Lock Bits				Protection description
Security level	LB1	LB2	LB3	
1	U	U	U	No program lock features enabled. Code verify will still be encrypted by the encryption array if programmed. MOVC instruction executed from external program memory returns non encrypted data.
2	P	U	U	MOVC instruction executed from external program memory are disabled from fetching code bytes from internal memory, EA is sampled and latched on reset, and further programming of the EPROM is disabled.
3	U	P	U	Same as 2, also verify is disabled.
4	U	U	P	Same as 3, also external execution is disabled.

U: unprogrammed,  
P: programmed

WARNING: Security level 2 and 3 should only be programmed after EPROM and Core verification.

#### 8.2.3. Signature bytes

The TS87C51RB2/RC2/RD2 contains 4 factory programmed signatures bytes. To read these bytes, perform the process described in section 8.3.

### 8.3. EPROM Programming

#### 8.3.1. Set-up modes

In order to program and verify the EPROM or to read the signature bytes, the TS87C51RB2/RC2/RD2 is placed in specific set-up modes (See Figure 18.).

Control and program signals must be held at the levels indicated in Table 30.

#### 8.3.2. Definition of terms







**Address Lines:** P1.0-P1.7, P2.0-P2.5, P3.4, P3.5 respectively for A0-A15 (P2.5 (A13) for RB, P3.4 (A14) for RC, P3.5 (A15) for RD)

**Data Lines:** P0.0-P0.7 for D0-D7

**Control Signals:** RST,  $\overline{\text{PSEN}}$ , P2.6, P2.7, P3.3, P3.6, P3.7.

**Program Signals:** ALE/ $\overline{\text{PROG}}$ ,  $\overline{\text{EA/VPP}}$ .

**Table 30. EPROM Set-Up Modes**

Mode	RST	PSEN	ALE/ PROG	$\overline{\text{EA/VPP}}$	P2.6	P2.7	P3.3	P3.6	P3.7
Program Code data	1	0		12.75V	0	1	1	1	1
Verify Code data	1	0	1	1	0		0	1	1
Program Encryption Array Address 0-3Fh	1	0		12.75V	0	1	1	0	1
Read Signature Bytes	1	0	1	1	0		0	0	0
Program Lock bit 1	1	0		12.75V	1	1	1	1	1
Program Lock bit 2	1	0		12.75V	1	1	1	0	0
Program Lock bit 3	1	0		12.75V	1	0	1	1	0

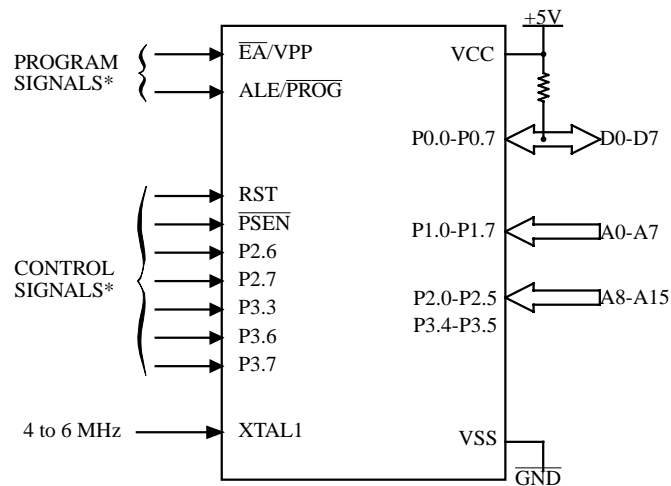

\* See Table 31. for proper value on these inputs

**Figure 18. Set-Up Modes Configuration**

### 8.3.3. Programming Algorithm

The Improved Quick Pulse algorithm is based on the Quick Pulse algorithm and decreases the number of pulses applied during byte programming from 25 to 1.

To program the TS87C51RB2/RC2/RD2 the following sequence must be exercised:

- Step 1: Activate the combination of control signals.
- Step 2: Input the valid address on the address lines.
- Step 3: Input the appropriate data on the data lines.
- Step 4: Raise  $\overline{EA}/VPP$  from VCC to VPP (typical 12.75V).
- Step 5: Pulse  $ALE/\overline{PROG}$  once.
- Step 6: Lower  $\overline{EA}/VPP$  from VPP to VCC

Repeat step 2 through 6 changing the address and data for the entire array or until the end of the object file is reached (See Figure 19.).

### 8.3.4. Verify algorithm

Code array verify must be done after each byte or block of bytes is programmed. In either case, a complete verify of the programmed array will ensure reliable programming of the TS87C51RB2/RC2/RD2.

P 2.7 is used to enable data output.

To verify the TS87C51RB2/RC2/RD2 code the following sequence must be exercised:

- Step 1: Activate the combination of program and control signals.
- Step 2: Input the valid address on the address lines.
- Step 3: Read data on the data lines.

Repeat step 2 through 3 changing the address for the entire array verification (See Figure 19.)

The encryption array cannot be directly verified. Verification of the encryption array is done by observing that the code array is well encrypted.

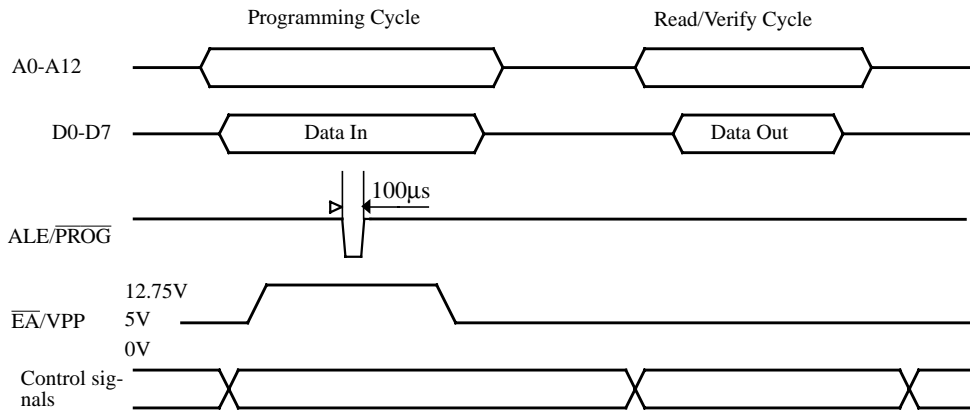

Figure 19. Programming and Verification Signal's Waveform

### 8.4. EPROM Erasure (Windowed Packages Only)

Erasing the EPROM erases the code array, the encryption array and the lock bits returning the parts to full functionality.

Erasure leaves all the EPROM cells in a 1's state (FF).

#### 8.4.1. Erasure Characteristics

The recommended erasure procedure is exposure to ultraviolet light (at 2537 Å) to an integrated dose at least 15 W-sec/cm<sup>2</sup>. Exposing the EPROM to an ultraviolet lamp of 12,000 μW/cm<sup>2</sup> rating for 30 minutes, at a distance of about 25 mm, should be sufficient. An exposure of 1 hour is recommended with most of standard erasers.

Erasure of the EPROM begins to occur when the chip is exposed to light with wavelength shorter than approximately 4,000 Å. Since sunlight and fluorescent lighting have wavelengths in this range, exposure to these light sources over an extended time (about 1 week in sunlight, or 3 years in room-level fluorescent lighting) could cause inadvertent erasure. If an application subjects the device to this type of exposure, it is suggested that an opaque label be placed over the window.

## 9. Signature Bytes

The TS83/87C51RB2/RC2/RD2 has four signature bytes in location 30h, 31h, 60h and 61h. To read these bytes follow the procedure for EPROM verify but activate the control lines provided in Table 31. for Read Signature Bytes. Table 31. shows the content of the signature byte for the TS87C51RB2/RC2/RD2.

**Table 31. Signature Bytes Content**

Location	Contents	Comment
30h	58h	Manufacturer Code: Atmel Wireless & Microcontrollers
31h	57h	Family Code: C51 X2
60h	7Ch	Product name: TS83C51RD2
60h	FCh	Product name: TS87C51RD2
60h	37h	Product name: TS83C51RC2
60h	B7h	Product name: TS87C51RC2
60h	3Bh	Product name: TS83C51RB2
60h	BBh	Product name: TS87C51RB2
61h	FFh	Product revision number



## 10. Electrical Characteristics

### 10.1. Absolute Maximum Ratings <sup>(1)</sup>

Ambiant Temperature Under Bias:	
C = commercial	0°C to 70°C
I = industrial	-40°C to 85°C
Storage Temperature	-65°C to + 150°C
Voltage on V <sub>CC</sub> to V <sub>SS</sub>	-0.5 V to + 7 V
Voltage on V <sub>PP</sub> to V <sub>SS</sub>	-0.5 V to + 13 V
Voltage on Any Pin to V <sub>SS</sub>	-0.5 V to V <sub>CC</sub> + 0.5 V
Power Dissipation	1 W <sup>(2)</sup>

#### NOTES

1. Stresses at or above those listed under “ Absolute Maximum Ratings” may cause permanent damage to the device. This is a stress rating only and functional operation of the device at these or any other conditions above those indicated in the operational sections of this specification is not implied. Exposure to absolute maximum rating conditions may affect device reliability.
2. This value is based on the maximum allowable die temperature and the thermal resistance of the package.

### 10.2. Power consumption measurement

Since the introduction of the first C51 devices, every manufacturer made operating I<sub>cc</sub> measurements under reset, which made sense for the designs were the CPU was running under reset. In Atmel Wireless & Microcontrollers new devices, the CPU is no more active during reset, so the power consumption is very low but is not really representative of what will happen in the customer system. That’s why, while keeping measurements under Reset, Atmel Wireless & Microcontrollers presents a new way to measure the operating I<sub>cc</sub>:

Using an internal test ROM, the following code is executed:

Label: SJMP Label (80 FE)

Ports 1, 2, 3 are disconnected, Port 0 is tied to FFh, EA = V<sub>cc</sub>, RST = V<sub>ss</sub>, XTAL2 is not connected and XTAL1 is driven by the clock.

This is much more representative of the real operating I<sub>cc</sub>.

### 10.3. DC Parameters for Standard Voltage

TA = 0°C to +70°C; V<sub>SS</sub> = 0 V; V<sub>CC</sub> = 5 V ± 10%; F = 0 to 40 MHz.

TA = -40°C to +85°C; V<sub>SS</sub> = 0 V; V<sub>CC</sub> = 5 V ± 10%; F = 0 to 40 MHz.

**Table 32. DC Parameters in Standard Voltage**

Symbol	Parameter	Min	Typ	Max	Unit	Test Conditions
V <sub>IL</sub>	Input Low Voltage	-0.5		0.2 V <sub>CC</sub> - 0.1	V	
V <sub>IH</sub>	Input High Voltage except XTAL1, RST	0.2 V <sub>CC</sub> + 0.9		V <sub>CC</sub> + 0.5	V	
V <sub>IH1</sub>	Input High Voltage, XTAL1, RST	0.7 V <sub>CC</sub>		V <sub>CC</sub> + 0.5	V	
V <sub>OL</sub>	Output Low Voltage, ports 1, 2, 3, 4, 5 <sup>(6)</sup>			0.3 0.45 1.0	V V V	I <sub>OL</sub> = 100 μA <sup>(4)</sup> I <sub>OL</sub> = 1.6 mA <sup>(4)</sup> I <sub>OL</sub> = 3.5 mA <sup>(4)</sup>
V <sub>OL1</sub>	Output Low Voltage, port 0 <sup>(6)</sup>			0.3 0.45 1.0	V V V	I <sub>OL</sub> = 200 μA <sup>(4)</sup> I <sub>OL</sub> = 3.2 mA <sup>(4)</sup> I <sub>OL</sub> = 7.0 mA <sup>(4)</sup>
V <sub>OL2</sub>	Output Low Voltage, ALE, $\overline{\text{PSEN}}$			0.3 0.45 1.0	V V V	I <sub>OL</sub> = 100 μA <sup>(4)</sup> I <sub>OL</sub> = 1.6 mA <sup>(4)</sup> I <sub>OL</sub> = 3.5 mA <sup>(4)</sup>
V <sub>OH</sub>	Output High Voltage, ports 1, 2, 3, 4, 5	V <sub>CC</sub> - 0.3 V <sub>CC</sub> - 0.7 V <sub>CC</sub> - 1.5			V V V	I <sub>OH</sub> = -10 μA I <sub>OH</sub> = -30 μA I <sub>OH</sub> = -60 μA V <sub>CC</sub> = 5 V ± 10%
V <sub>OH1</sub>	Output High Voltage, port 0	V <sub>CC</sub> - 0.3 V <sub>CC</sub> - 0.7 V <sub>CC</sub> - 1.5			V V V	I <sub>OH</sub> = -200 μA I <sub>OH</sub> = -3.2 mA I <sub>OH</sub> = -7.0 mA V <sub>CC</sub> = 5 V ± 10%
V <sub>OH2</sub>	Output High Voltage, ALE, $\overline{\text{PSEN}}$	V <sub>CC</sub> - 0.3 V <sub>CC</sub> - 0.7 V <sub>CC</sub> - 1.5			V V V	I <sub>OH</sub> = -100 μA I <sub>OH</sub> = -1.6 mA I <sub>OH</sub> = -3.5 mA V <sub>CC</sub> = 5 V ± 10%
R <sub>RST</sub>	RST Pulldown Resistor	50	90 <sup>(5)</sup>	200	kΩ	
I <sub>IL</sub>	Logical 0 Input Current ports 1, 2, 3, 4, 5			-50	μA	V <sub>in</sub> = 0.45 V
I <sub>LI</sub>	Input Leakage Current			±10	μA	0.45 V < V <sub>in</sub> < V <sub>CC</sub>
I <sub>TL</sub>	Logical 1 to 0 Transition Current, ports 1, 2, 3, 4, 5			-650	μA	V <sub>in</sub> = 2.0 V
C <sub>IO</sub>	Capacitance of I/O Buffer			10	pF	F <sub>c</sub> = 1 MHz T <sub>A</sub> = 25°C
I <sub>PD</sub>	Power Down Current		20 <sup>(5)</sup>	50	μA	2.0 V < V <sub>CC</sub> < 5.5 V <sup>(3)</sup>
I <sub>CC</sub> under RESET	Power Supply Current Maximum values, X1 mode: <sup>(7)</sup>			1 + 0.4 Freq (MHz) @12MHz 5.8 @16MHz 7.4	mA	V <sub>CC</sub> = 5.5 V <sup>(1)</sup>

Symbol	Parameter	Min	Typ	Max	Unit	Test Conditions
$I_{CC}$ operating	Power Supply Current Maximum values, X1 mode: <sup>(7)</sup>			3 + 0.6 Freq (MHz) @ 12MHz 10.2 @ 16MHz 12.6	mA	$V_{CC} = 5.5 \text{ V}^{(8)}$
$I_{CC}$ idle	Power Supply Current Maximum values, X1 mode: <sup>(7)</sup>			0.25+0.3 Freq (MHz) @ 12MHz 3.9 @ 16MHz 5.1	mA	$V_{CC} = 5.5 \text{ V}^{(2)}$

#### 10.4. DC Parameters for Low Voltage

$T_A = 0^\circ\text{C}$  to  $+70^\circ\text{C}$ ;  $V_{SS} = 0 \text{ V}$ ;  $V_{CC} = 2.7 \text{ V}$  to  $5.5 \text{ V} \pm 10\%$ ;  $F = 0$  to  $30 \text{ MHz}$ .

$T_A = -40^\circ\text{C}$  to  $+85^\circ\text{C}$ ;  $V_{SS} = 0 \text{ V}$ ;  $V_{CC} = 2.7 \text{ V}$  to  $5.5 \text{ V} \pm 10\%$ ;  $F = 0$  to  $30 \text{ MHz}$ .

**Table 33. DC Parameters for Low Voltage**

Symbol	Parameter	Min	Typ	Max	Unit	Test Conditions
$V_{IL}$	Input Low Voltage	-0.5		$0.2 V_{CC} - 0.1$	V	
$V_{IH}$	Input High Voltage except XTAL1, RST	$0.2 V_{CC} + 0.9$		$V_{CC} + 0.5$	V	
$V_{IHI}$	Input High Voltage, XTAL1, RST	$0.7 V_{CC}$		$V_{CC} + 0.5$	V	
$V_{OL}$	Output Low Voltage, ports 1, 2, 3, 4, 5 <sup>(6)</sup>			0.45	V	$I_{OL} = 0.8 \text{ mA}^{(4)}$
$V_{OL1}$	Output Low Voltage, port 0, ALE, $\overline{\text{PSEN}}$ <sup>(6)</sup>			0.45	V	$I_{OL} = 1.6 \text{ mA}^{(4)}$
$V_{OH}$	Output High Voltage, ports 1, 2, 3, 4, 5	$0.9 V_{CC}$			V	$I_{OH} = -10 \mu\text{A}$
$V_{OH1}$	Output High Voltage, port 0, ALE, $\overline{\text{PSEN}}$	$0.9 V_{CC}$			V	$I_{OH} = -40 \mu\text{A}$
$I_{IL}$	Logical 0 Input Current ports 1, 2, 3, 4, 5			-50	$\mu\text{A}$	$V_{in} = 0.45 \text{ V}$
$I_{LI}$	Input Leakage Current			$\pm 10$	$\mu\text{A}$	$0.45 \text{ V} < V_{in} < V_{CC}$
$I_{TL}$	Logical 1 to 0 Transition Current, ports 1, 2, 3, 4, 5			-650	$\mu\text{A}$	$V_{in} = 2.0 \text{ V}$
$R_{RST}$	RST Pulldown Resistor	50	90 <sup>(5)</sup>	200	k $\Omega$	
CIO	Capacitance of I/O Buffer			10	pF	$F_c = 1 \text{ MHz}$ $T_A = 25^\circ\text{C}$
$I_{PD}$	Power Down Current		20 <sup>(5)</sup> 10 <sup>(5)</sup>	50 30	$\mu\text{A}$	$V_{CC} = 2.0 \text{ V}$ to $5.5 \text{ V}^{(3)}$ $V_{CC} = 2.0 \text{ V}$ to $3.3 \text{ V}^{(3)}$
$I_{CC}$ under RESET	Power Supply Current Maximum values, X1 mode: <sup>(7)</sup>			1 + 0.2 Freq (MHz) @ 12MHz 3.4 @ 16MHz 4.2	mA	$V_{CC} = 3.3 \text{ V}^{(1)}$
$I_{CC}$ operating	Power Supply Current Maximum values, X1 mode: <sup>(7)</sup>			1 + 0.3 Freq (MHz) @ 12MHz 4.6 @ 16MHz 5.8	mA	$V_{CC} = 3.3 \text{ V}^{(8)}$

**TS80C51RA2/RD2**  
**TS83C51RB2/RC2/RD2**  
**TS87C51RB2/RC2/RD2**



Symbol	Parameter	Min	Typ	Max	Unit	Test Conditions
$I_{CC}$ idle	Power Supply Current Maximum values, X1 mode: <sup>(7)</sup>			0.15 Freq (MHz) + 0.2 @ 12MHz 2 @ 16MHz 2.6	mA	$V_{CC} = 3.3 \text{ V}^{(2)}$

**NOTES**

- $I_{CC}$  under reset is measured with all output pins disconnected; XTAL1 driven with  $T_{CLCH}$ ,  $T_{CHCL} = 5 \text{ ns}$  (see Figure 24.),  $V_{IL} = V_{SS} + 0.5 \text{ V}$ ,  $V_{IH} = V_{CC} - 0.5 \text{ V}$ ; XTAL2 N.C.;  $\overline{EA} = RST = \text{Port } 0 = V_{CC}$ .  $I_{CC}$  would be slightly higher if a crystal oscillator is used.
- Idle  $I_{CC}$  is measured with all output pins disconnected; XTAL1 driven with  $T_{CLCH}$ ,  $T_{CHCL} = 5 \text{ ns}$ ,  $V_{IL} = V_{SS} + 0.5 \text{ V}$ ,  $V_{IH} = V_{CC} - 0.5 \text{ V}$ ; XTAL2 N.C.; Port 0 =  $V_{CC}$ ;  $\overline{EA} = RST = V_{SS}$  (see Figure 22.).
- Power Down  $I_{CC}$  is measured with all output pins disconnected;  $\overline{EA} = V_{SS}$ , PORT 0 =  $V_{CC}$ ; XTAL2 N.C.; RST =  $V_{SS}$  (see Figure 23.).
- Capacitance loading on Ports 0 and 2 may cause spurious noise pulses to be superimposed on the  $V_{OL}$ s of ALE and Ports 1 and 3. The noise is due to external bus capacitance discharging into the Port 0 and Port 2 pins when these pins make 1 to 0 transitions during bus operation. In the worst cases (capacitive loading 100pF), the noise pulse on the ALE line may exceed 0.45V with maxi  $V_{OL}$  peak 0.6V. A Schmitt Trigger use is not necessary.
- Typicals are based on a limited number of samples and are not guaranteed. The values listed are at room temperature and 5V.
- Under steady state (non-transient) conditions,  $I_{OL}$  must be externally limited as follows:  
 Maximum  $I_{OL}$  per port pin: 10 mA  
 Maximum  $I_{OL}$  per 8-bit port:  
 Port 0: 26 mA  
 Ports 1, 2, 3 and 4 and 5 when available: 15 mA  
 Maximum total  $I_{OL}$  for all output pins: 71 mA  
 If  $I_{OL}$  exceeds the test condition,  $V_{OL}$  may exceed the related specification. Pins are not guaranteed to sink current greater than the listed test conditions.
- For other values, please contact your sales office.
- Operating  $I_{CC}$  is measured with all output pins disconnected; XTAL1 driven with  $T_{CLCH}$ ,  $T_{CHCL} = 5 \text{ ns}$  (see Figure 24.),  $V_{IL} = V_{SS} + 0.5 \text{ V}$ ,  $V_{IH} = V_{CC} - 0.5 \text{ V}$ ; XTAL2 N.C.;  $\overline{EA} = \text{Port } 0 = V_{CC}$ ; RST =  $V_{SS}$ . The internal ROM runs the code 80 FE (label: SJMP label).  $I_{CC}$  would be slightly higher if a crystal oscillator is used. Measurements are made with OTP products when possible, which is the worst case.

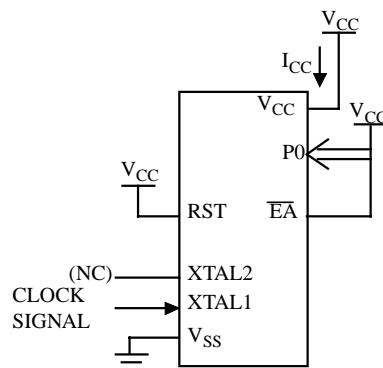

All other pins are disconnected.

**Figure 20.  $I_{CC}$  Test Condition, under reset**

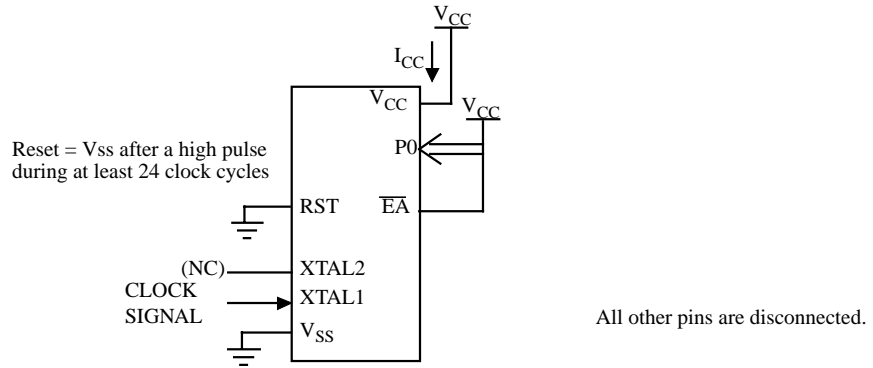

**Figure 21. Operating  $I_{CC}$  Test Condition**

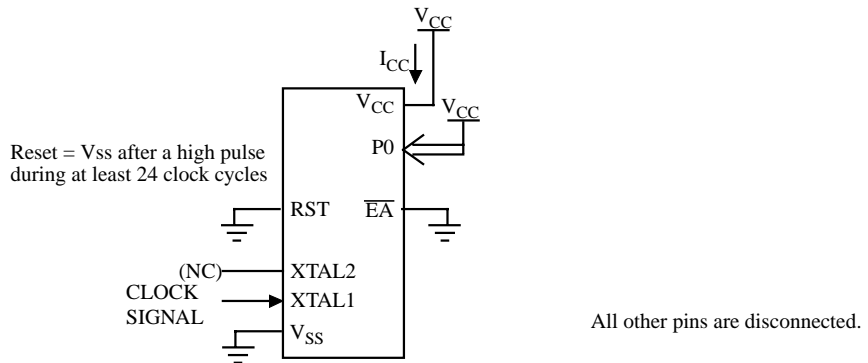

**Figure 22.  $I_{CC}$  Test Condition, Idle Mode**

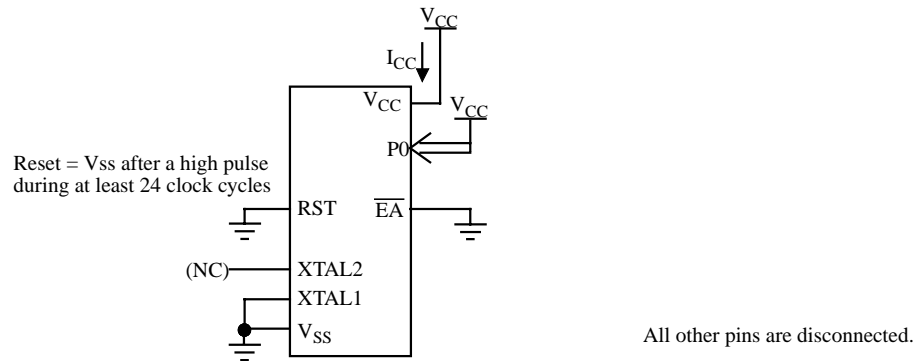

**Figure 23.  $I_{CC}$  Test Condition, Power-Down Mode**

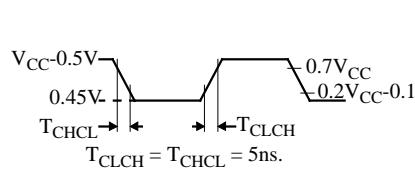

**Figure 24. Clock Signal Waveform for  $I_{CC}$  Tests in Active and Idle Modes**

## 10.5. AC Parameters

### 10.5.1. Explanation of the AC Symbols

Each timing symbol has 5 characters. The first character is always a “T” (stands for time). The other characters, depending on their positions, stand for the name of a signal or the logical status of that signal. The following is a list of all the characters and what they stand for.

Example:  $T_{AVLL}$  = Time for Address Valid to ALE Low.

$T_{LLPL}$  = Time for ALE Low to  $\overline{PSEN}$  Low.

$T_A = 0$  to  $+70^\circ\text{C}$  (commercial temperature range);  $V_{SS} = 0$  V;  $V_{CC} = 5$  V  $\pm$  10%; -M and -V ranges.

$T_A = -40^\circ\text{C}$  to  $+85^\circ\text{C}$  (industrial temperature range);  $V_{SS} = 0$  V;  $V_{CC} = 5$  V  $\pm$  10%; -M and -V ranges.

$T_A = 0$  to  $+70^\circ\text{C}$  (commercial temperature range);  $V_{SS} = 0$  V;  $2.7$  V  $< V_{CC} < 5.5$  V; -L range.

$T_A = -40^\circ\text{C}$  to  $+85^\circ\text{C}$  (industrial temperature range);  $V_{SS} = 0$  V;  $2.7$  V  $< V_{CC} < 5.5$  V; -L range.

Table 34. gives the maximum applicable load capacitance for Port 0, Port 1, 2 and 3, and ALE and  $\overline{PSEN}$  signals. Timings will be guaranteed if these capacitances are respected. Higher capacitance values can be used, but timings will then be degraded.

**Table 34. Load Capacitance versus speed range, in pF**

	-M	-V	-L
<b>Port 0</b>	100	50	100
<b>Port 1, 2, 3</b>	80	50	80
<b>ALE / <math>\overline{PSEN}</math></b>	100	30	100

Table 36., Table 39. and Table 42. give the description of each AC symbols.

Table 37., Table 40. and Table 43. give for each range the AC parameter.

Table 38., Table 41. and Table 44. give the frequency derating formula of the AC parameter. To calculate each AC symbols, take the x value corresponding to the speed grade you need (-M, -V or -L) and replace this value in the formula. Values of the frequency must be limited to the corresponding speed grade:

**Table 35. Max frequency for derating formula regarding the speed grade**

	-M X1 mode	-M X2 mode	-V X1 mode	-V X2 mode	-L X1 mode	-L X2 mode
<b>Freq (MHz)</b>	40	20	40	30	30	20
<b>T (ns)</b>	25	50	25	33.3	33.3	50

Example:

$T_{LLIV}$  in X2 mode for a -V part at 20 MHz ( $T = 1/20^{E6} = 50$  ns):

x= 22 (Table 38.)

T= 50ns

$T_{LLIV} = 2T - x = 2 \times 50 - 22 = 78$ ns

### 10.5.2. External Program Memory Characteristics

**Table 36. Symbol Description**

Symbol	Parameter
T	Oscillator clock period
T <sub>LHLL</sub>	ALE pulse width
T <sub>AVLL</sub>	Address Valid to ALE
T <sub>LLAX</sub>	Address Hold After ALE
T <sub>LLIV</sub>	ALE to Valid Instruction In
T <sub>LLPL</sub>	ALE to PSEN
T <sub>PLPH</sub>	PSEN Pulse Width
T <sub>PLIV</sub>	PSEN to Valid Instruction In
T <sub>PXIX</sub>	Input Instruction Hold After PSEN
T <sub>PXIZ</sub>	Input Instruction Float After PSEN
T <sub>PXAV</sub>	PSEN to Address Valid
T <sub>AVIV</sub>	Address to Valid Instruction In
T <sub>PLAZ</sub>	PSEN Low to Address Float

**Table 37. AC Parameters for Fix Clock**

Speed	-M 40 MHz		-V X2 mode 30 MHz 60 MHz equiv.		-V standard mode 40 MHz		-L X2 mode 20 MHz 40 MHz equiv.		-L standard mode 30 MHz		Units
	Min	Max	Min	Max	Min	Max	Min	Max	Min	Max	
Symbol											
T	25		33		25		50		33		ns
T <sub>LHLL</sub>	40		25		42		35		52		ns
T <sub>AVLL</sub>	10		4		12		5		13		ns
T <sub>LLAX</sub>	10		4		12		5		13		ns
T <sub>LLIV</sub>		70		45		78		65		98	ns
T <sub>LLPL</sub>	15		9		17		10		18		ns
T <sub>PLPH</sub>	55		35		60		50		75		ns
T <sub>PLIV</sub>		35		25		50		30		55	ns
T <sub>PXIX</sub>	0		0		0		0		0		ns
T <sub>PXIZ</sub>		18		12		20		10		18	ns
T <sub>AVIV</sub>		85		53		95		80		122	ns
T <sub>PLAZ</sub>		10		10		10		10		10	ns

Table 38. AC Parameters for a Variable Clock: derating formula

Symbol	Type	Standard Clock	X2 Clock	-M	-V	-L	Units
$T_{LHLL}$	Min	$2 T - x$	$T - x$	10	8	15	ns
$T_{AVLL}$	Min	$T - x$	$0.5 T - x$	15	13	20	ns
$T_{LLAX}$	Min	$T - x$	$0.5 T - x$	15	13	20	ns
$T_{LLIV}$	Max	$4 T - x$	$2 T - x$	30	22	35	ns
$T_{LLPL}$	Min	$T - x$	$0.5 T - x$	10	8	15	ns
$T_{PLPH}$	Min	$3 T - x$	$1.5 T - x$	20	15	25	ns
$T_{PLIV}$	Max	$3 T - x$	$1.5 T - x$	40	25	45	ns
$T_{PXIX}$	Min	x	x	0	0	0	ns
$T_{PXIZ}$	Max	$T - x$	$0.5 T - x$	7	5	15	ns
$T_{AVIV}$	Max	$5 T - x$	$2.5 T - x$	40	30	45	ns
$T_{PLAZ}$	Max	x	x	10	10	10	ns

### 10.5.3. External Program Memory Read Cycle

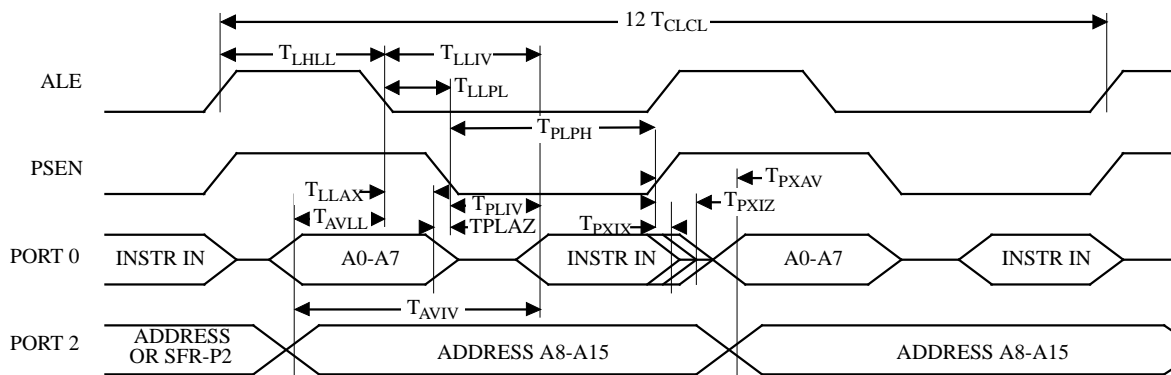

Figure 25. External Program Memory Read Cycle



#### 10.5.4. External Data Memory Characteristics

Table 39. Symbol Description

Symbol	Parameter
$T_{RLRH}$	$\overline{RD}$ Pulse Width
$T_{WLWH}$	$\overline{WR}$ Pulse Width
$T_{RLDV}$	$\overline{RD}$ to Valid Data In
$T_{RHDX}$	Data Hold After $\overline{RD}$
$T_{RHDX}$	Data Float After $\overline{RD}$
$T_{LLDV}$	ALE to Valid Data In
$T_{AVDV}$	Address to Valid Data In
$T_{LLWL}$	ALE to $\overline{WR}$ or $\overline{RD}$
$T_{AVWL}$	Address to $\overline{WR}$ or $\overline{RD}$
$T_{QVWX}$	Data Valid to $\overline{WR}$ Transition
$T_{QVWH}$	Data set-up to $\overline{WR}$ High
$T_{WHQX}$	Data Hold After $\overline{WR}$
$T_{RLAZ}$	$\overline{RD}$ Low to Address Float
$T_{WHLH}$	$\overline{RD}$ or $\overline{WR}$ High to ALE high

**Table 40. AC Parameters for a Fix Clock**

Speed	-M 40 MHz		-V X2 mode 30 MHz 60 MHz equiv.		-V standard mode 40 MHz		-L X2 mode 20 MHz 40 MHz equiv.		-L standard mode 30 MHz		Units
	Min	Max	Min	Max	Min	Max	Min	Max	Min	Max	
T <sub>RLRH</sub>	130		85		135		125		175		ns
T <sub>WLWH</sub>	130		85		135		125		175		ns
T <sub>RLDV</sub>		100		60		102		95		137	ns
T <sub>RHDX</sub>	0		0		0		0		0		ns
T <sub>RHDZ</sub>		30		18		35		25		42	ns
T <sub>LLDV</sub>		160		98		165		155		222	ns
T <sub>AVDV</sub>		165		100		175		160		235	ns
T <sub>LLWL</sub>	50	100	30	70	55	95	45	105	70	130	ns
T <sub>AVWL</sub>	75		47		80		70		103		ns
T <sub>QVWX</sub>	10		7		15		5		13		ns
T <sub>QVWH</sub>	160		107		165		155		213		ns
T <sub>WHQX</sub>	15		9		17		10		18		ns
T <sub>RLAZ</sub>		0		0		0		0		0	ns
T <sub>WHLH</sub>	10	40	7	27	15	35	5	45	13	53	ns

**Table 41. AC Parameters for a Variable Clock: derating formula**

Symbol	Type	Standard Clock	X2 Clock	-M	-V	-L	Units
$T_{RLRH}$	Min	6 T - x	3 T - x	20	15	25	ns
$T_{WLWH}$	Min	6 T - x	3 T - x	20	15	25	ns
$T_{RLDV}$	Max	5 T - x	2.5 T - x	25	23	30	ns
$T_{RHDX}$	Min	x	x	0	0	0	ns
$T_{RHDZ}$	Max	2 T - x	T - x	20	15	25	ns
$T_{LLDV}$	Max	8 T - x	4T - x	40	35	45	ns
$T_{AVDV}$	Max	9 T - x	4.5 T - x	60	50	65	ns
$T_{LLWL}$	Min	3 T - x	1.5 T - x	25	20	30	ns
$T_{LLWL}$	Max	3 T + x	1.5 T + x	25	20	30	ns
$T_{AVWL}$	Min	4 T - x	2 T - x	25	20	30	ns
$T_{QVWX}$	Min	T - x	0.5 T - x	15	10	20	ns
$T_{QVWH}$	Min	7 T - x	3.5 T - x	15	10	20	ns
$T_{WHQX}$	Min	T - x	0.5 T - x	10	8	15	ns
$T_{RLAZ}$	Max	x	x	0	0	0	ns
$T_{WHLH}$	Min	T - x	0.5 T - x	15	10	20	ns
$T_{WHLH}$	Max	T + x	0.5 T + x	15	10	20	ns

**10.5.5. External Data Memory Write Cycle**

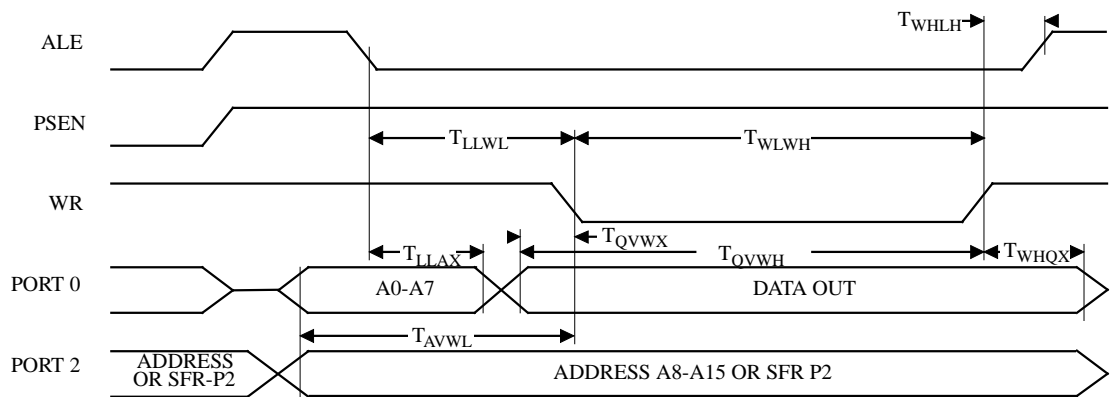

**Figure 26. External Data Memory Write Cycle**

10.5.6. External Data Memory Read Cycle

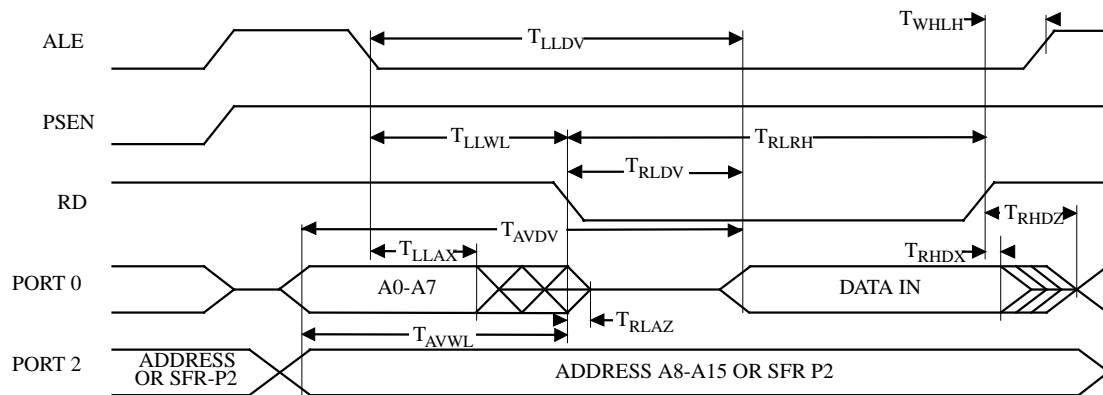

Figure 27. External Data Memory Read Cycle

10.5.7. Serial Port Timing - Shift Register Mode

Table 42. Symbol Description

Symbol	Parameter
$T_{XLXL}$	Serial port clock cycle time
$T_{QVHX}$	Output data set-up to clock rising edge
$T_{XHQX}$	Output data hold after clock rising edge
$T_{XHDX}$	Input data hold after clock rising edge
$T_{XHDV}$	Clock rising edge to input data valid

Table 43. AC Parameters for a Fix Clock

Speed	-M 40 MHz		-V X2 mode 30 MHz 60 MHz equiv.		-V standard mode 40 MHz		-L X2 mode 20 MHz 40 MHz equiv.		-L standard mode 30 MHz		Units
	Min	Max	Min	Max	Min	Max	Min	Max	Min	Max	
$T_{XLXL}$	300		200		300		300		400		ns
$T_{QVHX}$	200		117		200		200		283		ns
$T_{XHQX}$	30		13		30		30		47		ns
$T_{XHDX}$	0		0		0		0		0		ns
$T_{XHDV}$		117		34		117		117		200	ns

**Table 44. AC Parameters for a Variable Clock: derating formula**

Symbol	Type	Standard Clock	X2 Clock	-M	-V	-L	Units
$T_{XLXL}$	Min	12 T	6 T				ns
$T_{QVXH}$	Min	10 T - x	5 T - x	50	50	50	ns
$T_{XHQX}$	Min	2 T - x	T - x	20	20	20	ns
$T_{XHDX}$	Min	x	x	0	0	0	ns
$T_{XHDV}$	Max	10 T - x	5 T - x	133	133	133	ns

**10.5.8. Shift Register Timing Waveforms**

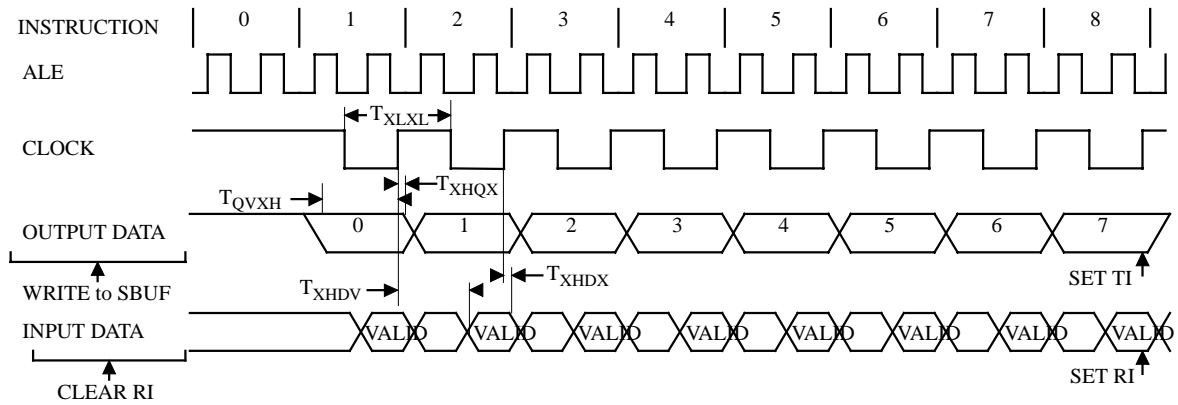

**Figure 28. Shift Register Timing Waveforms**

### 10.5.9. EPROM Programming and Verification Characteristics

$T_A = 21^\circ\text{C}$  to  $27^\circ\text{C}$ ;  $V_{SS} = 0\text{V}$ ;  $V_{CC} = 5\text{V} \pm 10\%$  while programming.  $V_{CC}$  = operating range while verifying

**Table 45. EPROM Programming Parameters**

Symbol	Parameter	Min	Max	Units
$V_{PP}$	Programming Supply Voltage	12.5	13	V
$I_{PP}$	Programming Supply Current		75	mA
$1/T_{CLCL}$	Oscillator Frquency	4	6	MHz
$T_{AVGL}$	Address Setup to $\overline{\text{PROG}}$ Low	$48 T_{CLCL}$		
$T_{GHAX}$	Adress Hold after $\overline{\text{PROG}}$	$48 T_{CLCL}$		
$T_{DVGL}$	Data Setup to $\overline{\text{PROG}}$ Low	$48 T_{CLCL}$		
$T_{GHDX}$	Data Hold after $\overline{\text{PROG}}$	$48 T_{CLCL}$		
$T_{EHS}$	(Enable) High to $V_{PP}$	$48 T_{CLCL}$		
$T_{SHGL}$	$V_{PP}$ Setup to $\overline{\text{PROG}}$ Low	10		$\mu\text{s}$
$T_{GHSL}$	$V_{PP}$ Hold after $\overline{\text{PROG}}$	10		$\mu\text{s}$
$T_{GLGH}$	$\overline{\text{PROG}}$ Width	90	110	$\mu\text{s}$
$T_{AVQV}$	Address to Valid Data		$48 T_{CLCL}$	
$T_{ELQV}$	ENABLE Low to Data Valid		$48 T_{CLCL}$	
$T_{EHQZ}$	Data Float after ENABLE	0	$48 T_{CLCL}$	

### 10.5.10. EPROM Programming and Verification Waveforms

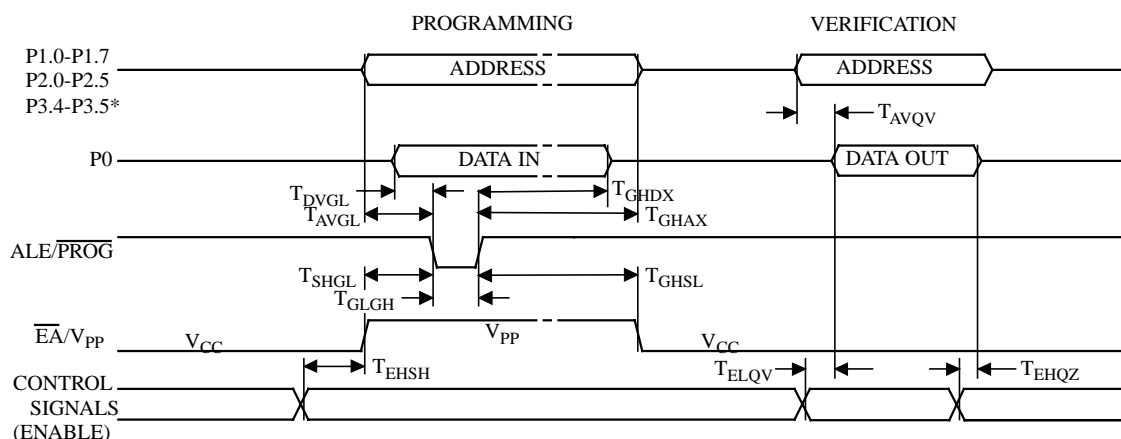

\* 8KB: up to P2.4, 16KB: up to P2.5, 32KB: up to P3.4, 64KB: up to P3.5

**Figure 29. EPROM Programming and Verification Waveforms**

**10.5.11. External Clock Drive Characteristics (XTAL1)**

**Table 46. AC Parameters**

Symbol	Parameter	Min	Max	Units
$T_{CLCL}$	Oscillator Period	25		ns
$T_{CHCX}$	High Time	5		ns
$T_{CLCX}$	Low Time	5		ns
$T_{CLCH}$	Rise Time		5	ns
$T_{CHCL}$	Fall Time		5	ns
$T_{CHCX}/T_{CLCX}$	Cyclic ratio in X2 mode	40	60	%

**10.5.12. External Clock Drive Waveforms**

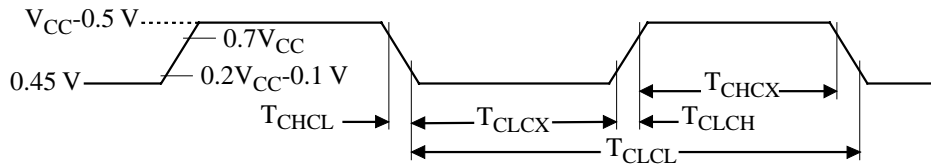

**Figure 30. External Clock Drive Waveforms**

**10.5.13. AC Testing Input/Output Waveforms**

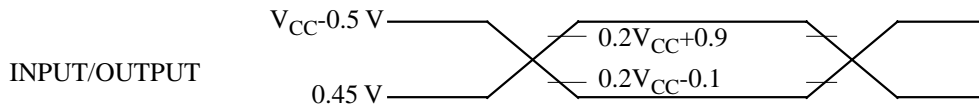

**Figure 31. AC Testing Input/Output Waveforms**

AC inputs during testing are driven at  $V_{CC} - 0.5$  for a logic “1” and 0.45V for a logic “0”. Timing measurement are made at  $V_{IH}$  min for a logic “1” and  $V_{IL}$  max for a logic “0”.

**10.5.14. Float Waveforms**

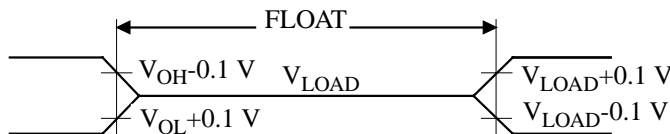
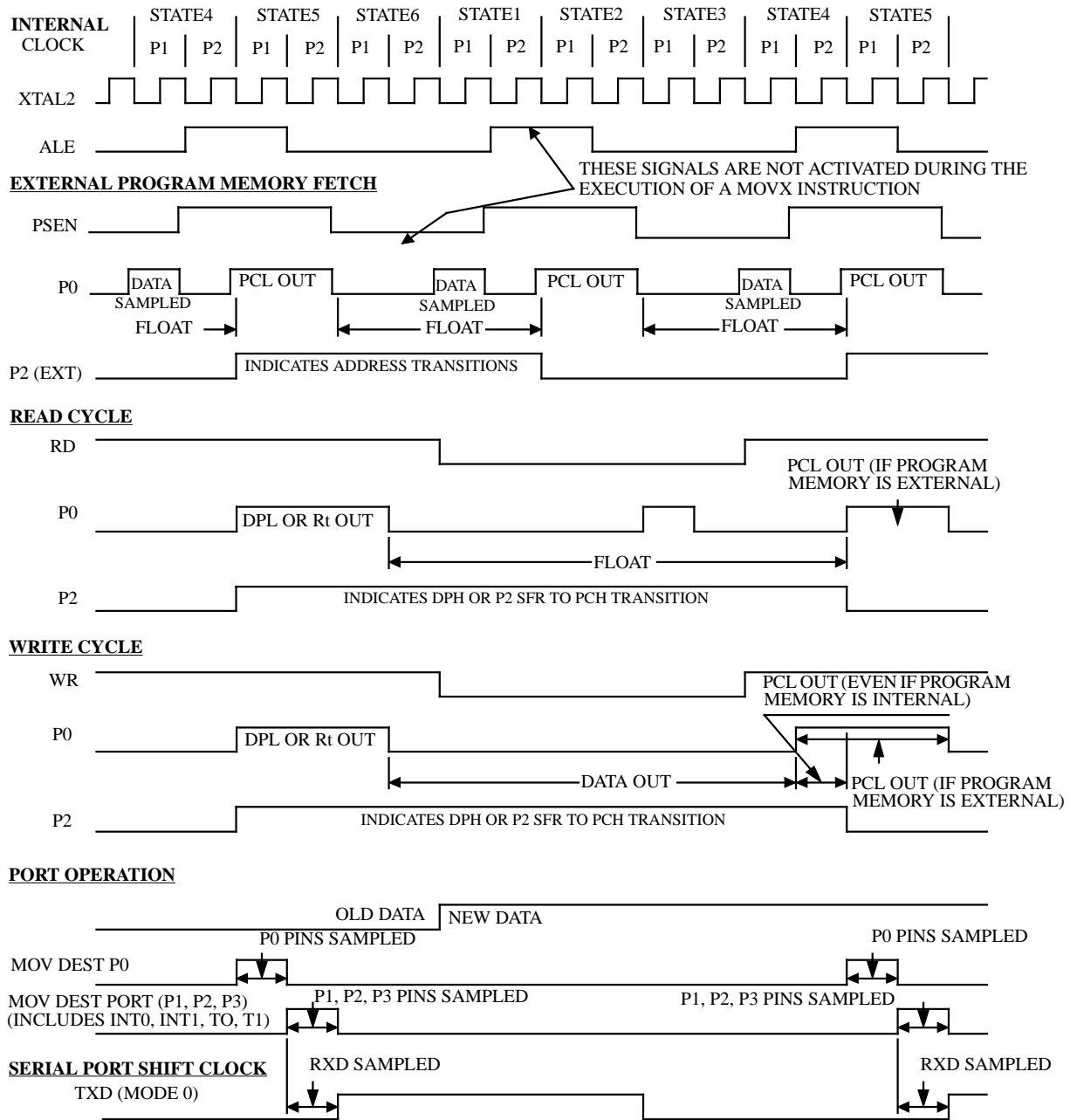

**Figure 32. Float Waveforms**

For timing purposes a port pin is no longer floating when a 100 mV change from load voltage occurs and begins to float when a 100 mV change from the loaded  $V_{OH}/V_{OL}$  level occurs.  $I_{OL}/I_{OH} \geq \pm 20mA$ .

### 10.5.15. Clock Waveforms

Valid in normal clock mode. In X2 mode XTAL2 signal must be changed to XTAL2 divided by two.

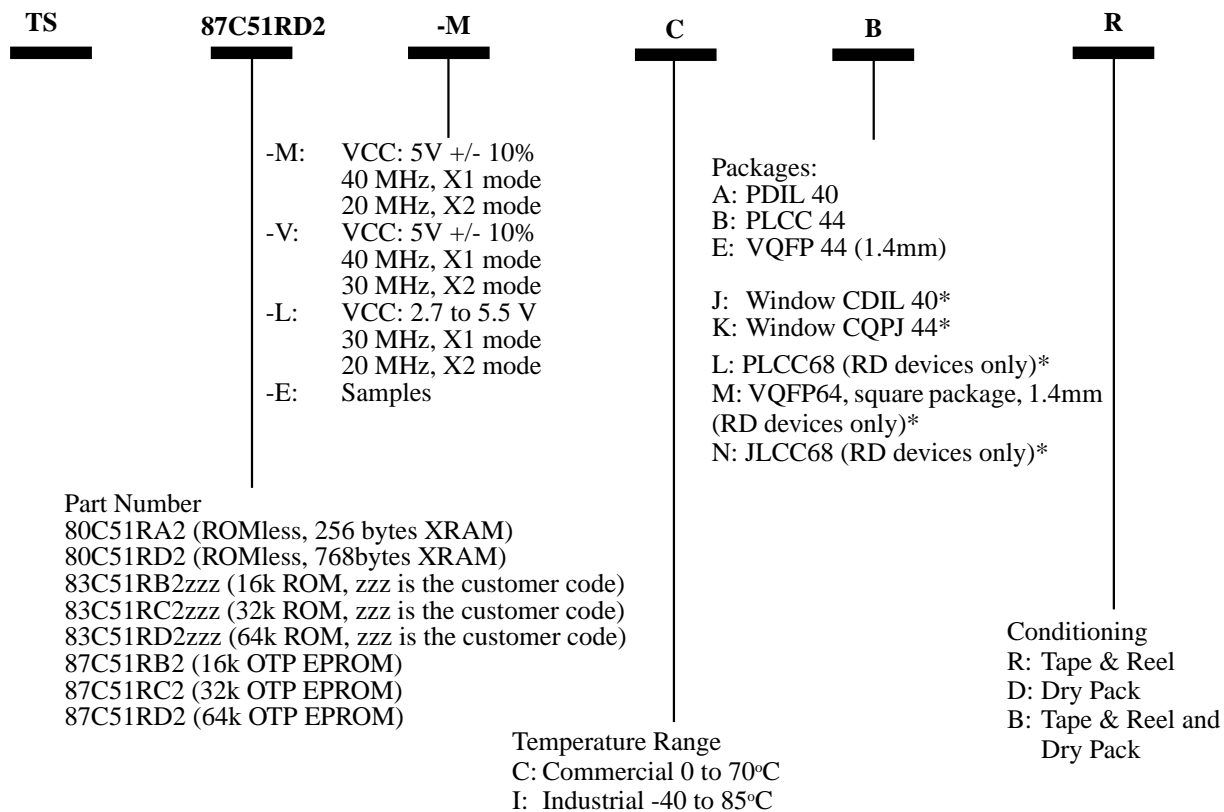

**Figure 33. Clock Waveforms**

This diagram indicates when signals are clocked internally. The time it takes the signals to propagate to the pins, however, ranges from 25 to 125 ns. This propagation delay is dependent on variables such as temperature and pin loading. Propagation also varies from output to output and component. Typically though ( $T_A=25^\circ C$  fully loaded)  $\overline{RD}$  and  $\overline{WR}$  propagation delays are approximately 50ns. The other signals are typically 85 ns. Propagation delays are incorporated in the AC specifications.



## 11. Ordering Information



(\* Check with Atmel Wireless & Microcontrollers Sales Office for availability. Ceramic packages (J, K, N) are available for proto typing, not for volume production. Ceramic packages are available for OTP only.

**Table 47. Maximum Clock Frequency**

Code	-M	-V	-L	Unit
Standard Mode, oscillator frequency	40	40	30	MHz
Standard Mode, internal frequency	40	40	30	
X2 Mode, oscillator frequency	20	30	20	MHz
X2 Mode, internal equivalent frequency	40	<b>60</b>	<b>40</b>	

**Table 48. Possible Ordering Entries**

	TS80C51RA2/RD2 ROMless	TS83C51RB2/RC2/RD2 <sup>zzz</sup> ROM	TS87C51RB2/RC2/RD2 OTP
-MCA	X	X	X
-MCB	X	X	X
-MCE	X	X	X
-MCL	RD2 only	RD2 only	RD2 only
-MCM	RD2 only	RD2 only	RD2 only
-VCA	X	X	X
-VCB	X	X	X
-VCE	X	X	X
-VCL	RD2 only	RD2 only	RD2 only
-VCM	RD2 only	RD2 only	RD2 only
-LCA	X	X	X
-LCB	X	X	X
-LCE	X	X	X
-LCL	RD2 only	RD2 only	RD2 only
-LCM	RD2 only	RD2 only	RD2 only
-MIA	X	X	X
-MIB	X	X	X
-MIE	X	X	X
-MIL	RD2 only	RD2 only	RD2 only
-MIM	RD2 only	RD2 only	RD2 only
-VIA	X	X	X
-VIB	X	X	X
-VIE	X	X	X
-VIL	RD2 only	RD2 only	RD2 only
-VIM	RD2 only	RD2 only	RD2 only
-LIA	X	X	X
-LIB	X	X	X
-LIE	X	X	X
-LIL	RD2 only	RD2 only	RD2 only
-LIM	RD2 only	RD2 only	RD2 only
-EA	X		X
-EB	X		X
-EE	X		X
-EL	RD2 only		RD2 only
-EM	RD2 only		RD2 only
-EJ			RC2 and RD2 only
-EK			RC2 and RD2 only
-EN			RD2 only

- -Ex for samples
- Tape and Reel available for B, E, L and M packages
- Dry pack mandatory for E and M packages