

DRAWING NO.

E1134-507

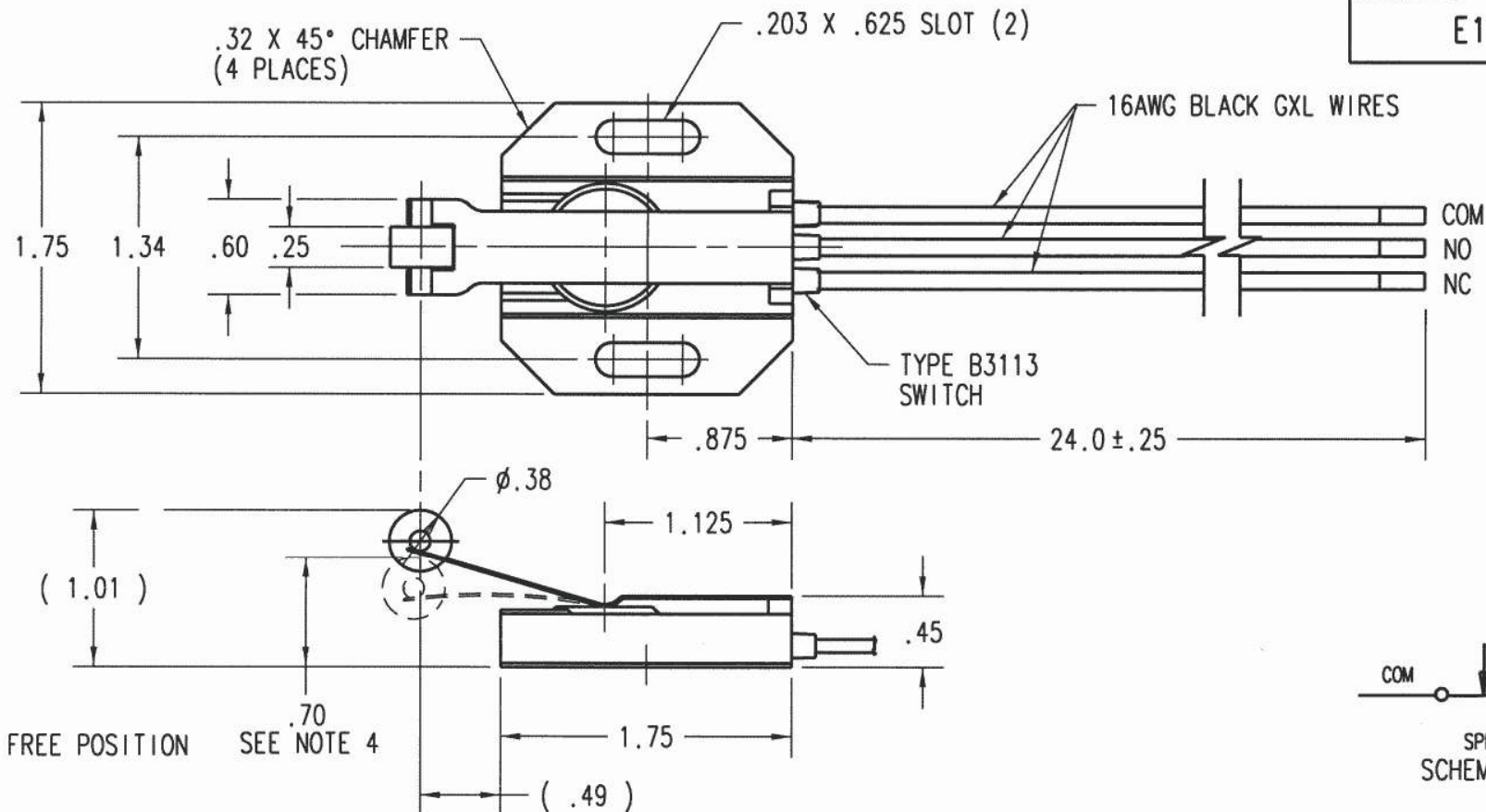

NOTES:

- ENTIRE SWITCH BRACKET IS STAINLESS STEEL. ROLLER IS DELRIN.
- SWITCH IS COMPLETELY WATERPROOF.
- WIRE CONNECTIONS MUST BE SEALED TO MAINTAIN THE WATERPROOFNESS OF THE SWITCH.
- MINIMUM POSITION FOR UNLIMITED ACTUATOR ENDURANCE.
- SWITCH ACTION: SPDT
- ELECTRICAL RATING (28VDC/120VAC): 5 AMP RESISTIVE, 3 AMP INDUCTIVE.
- PROPER APPLICATION OF THIS PRODUCT IS THE RESPONSIBILITY OF THE USER.

REV	DESCRIPTION	DATE	BY	APP	UNLESS OTHERWISE SPECIFIED DIMENSIONS ARE IN INCHES		APPROVALS		DATE	CPI CONTROL PRODUCTS, INC. EAST HANOVER, NEW JERSEY WWW.CPI-NJ.COM			
					TOLERANCES ARE:		DRAWN	GHS	7/26/21	TITLE LIMIT SWITCH, SPDT INSTALLATION DRAWING			
					.X ± .1	.XX ± .03	.XXX ± .015	ANG ± 5°	CHECKED				
					MATERIAL		ISSUED	ECN7184	7/27/21	SIZE A			
					FINISH AND HEAT TREAT		DIGI-KEY						
REVISIONS					DO NOT SCALE DRAWING								
THE INFORMATION FURNISHED HEREIN IS THE PROPERTY OF CONTROL PRODUCTS, INC. AND SHALL NOT BE USED, DISCLOSED TO OTHERS, OR COPIED WITHOUT THE EXPRESS WRITTEN CONSENT OF CONTROL PRODUCTS, INC.													