

**DESIGNED & DIMENSIONED
IN MILLIMETERS[INCHES]**

SS5-XX-X.XX-X-D-K-XR

DO NOT
SCALE FROM
THIS PRINT

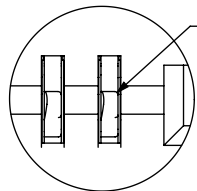
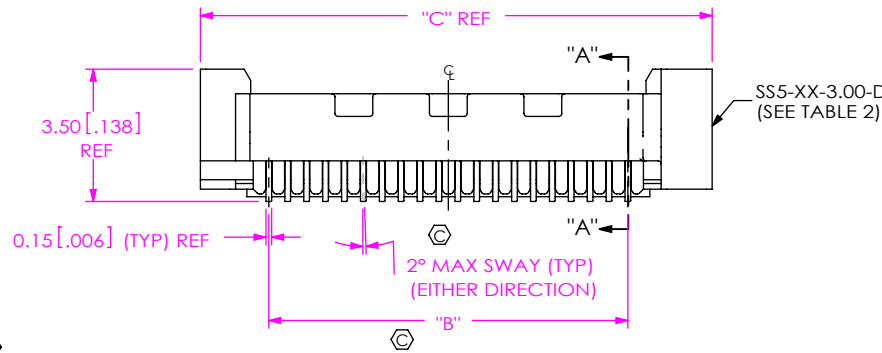
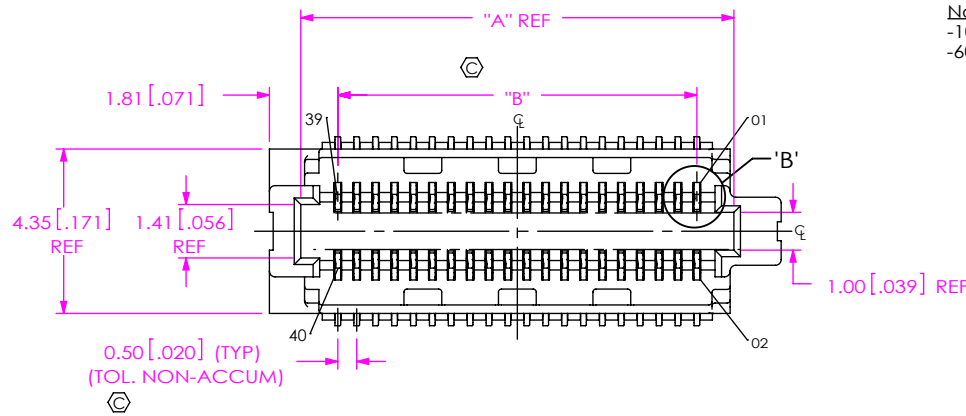

DETAIL 'B'
SCALE 15:1

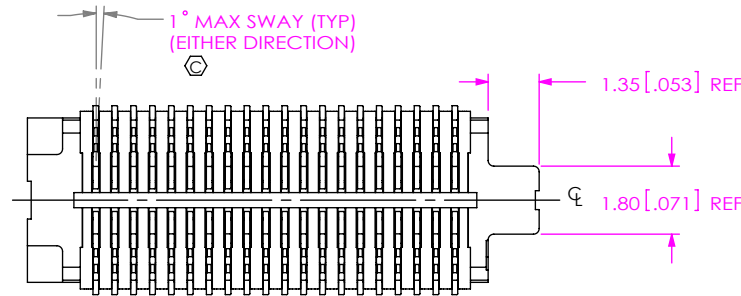

FIG 1
SS5-20-3.00-X-D-K-XR SHOWN

No OF POSITIONS
-10, -15, -20, -30, -40, -50
-60, -70, -80 (PER ROW)

LEAD STYLE
-3.00: (USE C-229-3.00-X)
-3.50: (USE C-229-3.50-X)

PLATING SPECIFICATION
-L: 10µ" SELECTIVE GOLD
IN CONTACT AREA,
MATTE TIN ON TAIL

TAPE & REEL (SEE NOTES 4 & 5)
-TR: TAPE AND REEL
-FR: FULL REEL QTY TAPE & REEL

PLACEMENT PAD
-K: KAPTON PAD
(USE K-DOT-.138-.250-.005)
(SEE FIG 3, SHT 2)

ROW SPECIFICATION
-D: DOUBLE

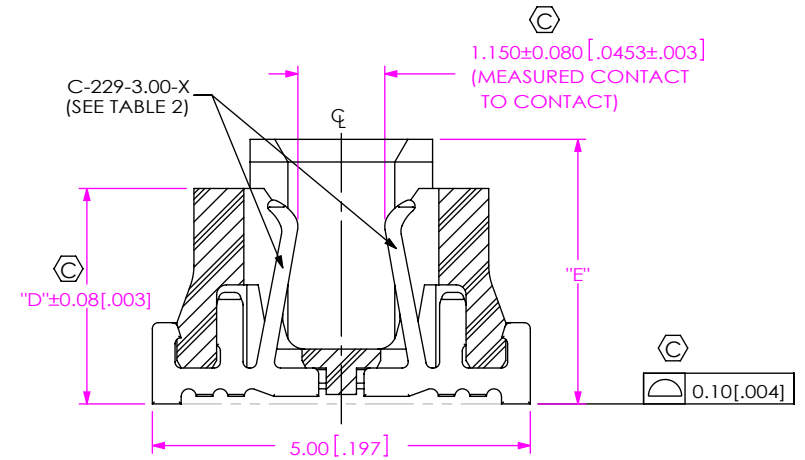

SECTION "A"- "A"
SCALE 10:1

No OF POS	"A"	"B"	"C"
-10	6.46 [0.254]	4.50 [0.177]	8.54 [0.336]
-15	8.96 [0.353]	7.00 [0.276]	11.04 [0.435]
-20	11.46 [0.451]	9.50 [0.374]	13.54 [0.533]
-30	16.46 [0.648]	14.50 [0.571]	18.54 [0.730]
-40	21.46 [0.845]	19.50 [0.768]	23.54 [0.927]
-50	26.46 [1.042]	24.50 [0.965]	28.54 [1.124]
-60	31.46 [1.239]	29.50 [1.161]	33.54 [1.320]
-70	36.46 [1.435]	34.50 [1.358]	38.54 [1.517]
-80	41.46 [1.632]	39.50 [1.555]	43.54 [1.714]

LEAD STYLE	"D"	"E"	BODY	CONTACT
-3.00	2.85 [0.112]	3.50 [0.138]	SS5-XX-3.00-D	C-229-3.00-X
-3.50	3.35 [0.132]	4.00 [0.157]	SS5-XX-3.00-D	C-229-3.50-X

NOTES:

- ⊕ REPRESENTS A CRITICAL DIMENSION.
- MINIMUM PUSHOUT FORCE: 1.11N[.5 LB].
- NOTE DELETED.
- ORDERS WILL BE PACKAGED ACCORDING TO THE SAMTEC PACKAGING EFFICIENCY STANDARDS (SPES) FOUND ON WWW.SAMTEC.COM.
- ATTACH LABEL TO EACH REEL.

UNLESS OTHERWISE SPECIFIED,
DIMENSIONS ARE IN MILLIMETERS.
TOLERANCES ARE:
DECIMALS ANGLES
.X: ±0.3 [0.1] 2°
.XX: ±0.13 [0.005]
.XXX: ±0.051 [0.0020]

PROPRIETARY NOTE
THIS DOCUMENT CONTAINS CONFIDENTIAL AND PROPRIETARY INFORMATION AND ALL DESIGN, MANUFACTURING, REPRODUCTION, USE, PATENT RIGHTS AND SALES RIGHTS ARE EXPRESSLY RESERVED BY SAMTEC, INC. THIS DOCUMENT SHALL NOT BE DISCLOSED, IN WHOLE OR PART, TO ANY UNAUTHORIZED PERSON OR ENTITY NOR REPRODUCED, TRANSFERRED OR INCORPORATED IN ANY OTHER PROJECT IN ANY MANNER WITHOUT THE EXPRESS WRITTEN CONSENT OF SAMTEC, INC.



520 PARK EAST BLVD, NEW ALBANY, IN 47150
PHONE: 812-944-6733 FAX: 812-948-5047
e-Mail: info@SAMTEC.com code: 55322

MATERIAL: DO NOT SCALE DRAWING SHEET SCALE: 5:1
INSULATOR: LCP, COLOR: BLACK
CONTACT: PHOS BRONZE

DESCRIPTION:
0.50mm SOCKET STRIP ASSEMBLY
DWG. NO.

SS5-XX-X.XX-X-D-K-XR

BY: VICKY Z 04/02/2012 SHEET 1 OF 2

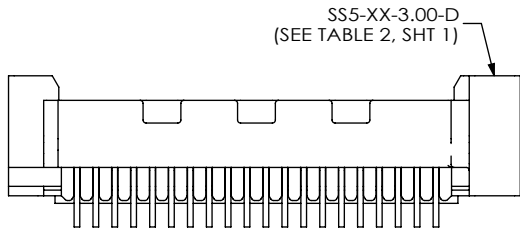

FIG 2
SS5-20-3.50-X-D-XR SHOWN
(DIFFERENT AS SHOWN, OTHERWISE SAME AS FIG 1)

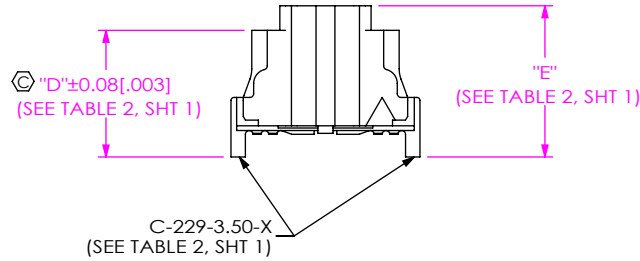

TABLE 3 REF			
STACK HEIGHT			
SS5 LEAD STYLE	ST5 LEAD STYLE		
		-1.00	-1.50
-3.00	4.0MM	4.5MM	5.5MM
-3.50	4.5MM	5.0MM	6.0MM

(** = NOT TOOLED)

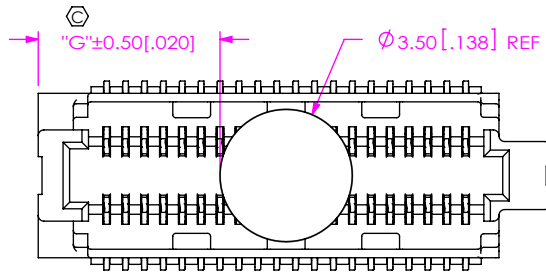

FIG 3
-K: KAPTON OPTION
SS5-20-3.00-X-D-K-XR SHOWN
(USE K-DOT-.138-.250-.005)
(DIFFERENT AS SHOWN, OTHERWISE SAME AS FIG 1)

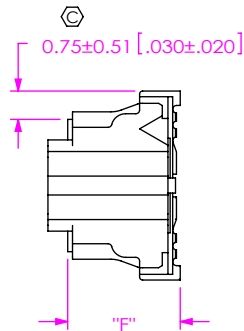

TABLE 4	
LEAD STYLE	"F"
-3.00	2.98 [0.117]
-3.50	3.48 [0.137]

TABLE 5	
No OF POS	"G"
-10	2.31 [0.091]
-15	3.56 [0.140]
-20	4.81 [0.189]
-30	7.31 [0.288]
-40	9.81 [0.386]
-50	12.31 [0.485]
-60	14.81 [0.583]
-70	17.31 [0.681]
-80	19.81 [0.780]

F:\DWG\MISC\MKTG\SS5-XX-X.XX-X-D-K-XR-MKT.SLDDRW

PROPRIETARY NOTE
THIS DOCUMENT CONTAINS CONFIDENTIAL AND PROPRIETARY INFORMATION AND ALL DESIGN, MANUFACTURING, REPRODUCTION, USE, PATENT RIGHTS AND SALES RIGHTS ARE EXPRESSLY RESERVED BY SAMTEC, INC. THIS DOCUMENT SHALL NOT BE DISCLOSED, IN WHOLE OR PART, TO ANY UNAUTHORIZED PERSON OR ENTITY NOR REPRODUCED, TRANSFERRED OR INCORPORATED IN ANY OTHER PROJECT IN ANY MANNER WITHOUT THE EXPRESS WRITTEN CONSENT OF SAMTEC, INC.

DO NOT SCALE DRAWING

SHEET SCALE: 5:1



520 PARK EAST BLVD, NEW ALBANY, IN 47150
PHONE: 812-944-6733 FAX: 812-948-5047
e-Mail: info@SAMTEC.com code: 55322

DESCRIPTION:
0.50mm SOCKET STRIP ASSEMBLY

DWG. NO.
SS5-XX-X.XX-X-D-K-XR

BY: VICKY Z 04/02/2012 SHEET 2 OF 2