

REVISIONS					
REV	ECO	DESCRIPTION	DATE	BY	APPR
B1	-	RELEASED DRAWING	July-07-2014	Ben	Tommy
B2	-	MODIFY THE INSERT LETTER LOCATION	May-20-2016	Ben	Tommy
B3	-	ADAPT TO CHANGE OF WIRE DIAMETER	Jan-7-2020	Ronald	Tommy

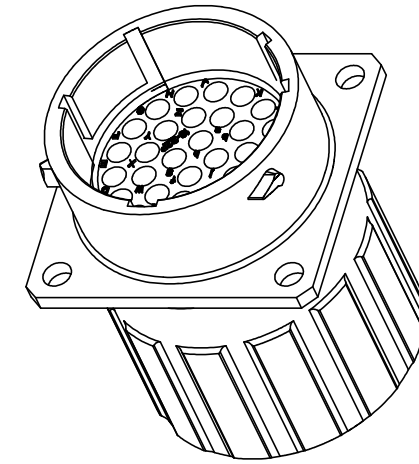
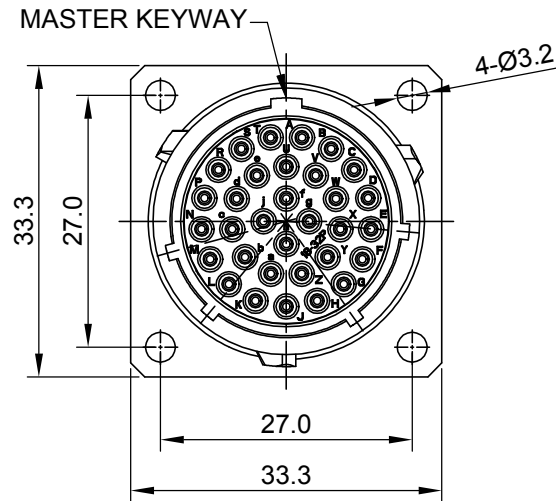
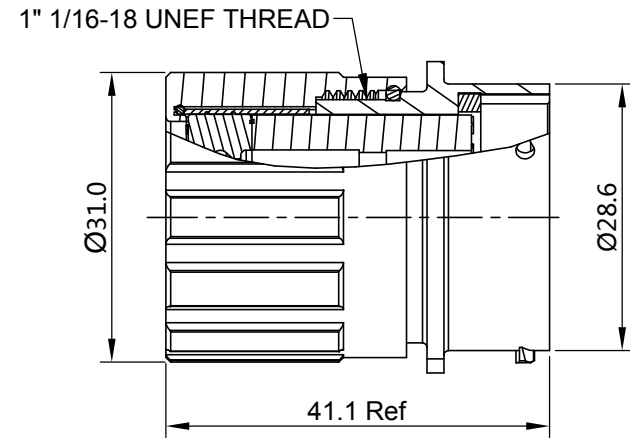

NOTES : (UNLESS OTHERWISE SPECIFIED)

- MATERIAL :
 - SHELL : ZINC ALLOY , NICKEL PLATED.
 - INSERT : THERMOPLASTIC , UL94 V-0.
 - END CAP : THERMOPLASTIC , UL94 V-0.
 - SEAL GASKET : NBR/SILICONE RUBBER.
 - O-RING : NBR/SILICONE RUBBER.
 - WIRE SEAL : SILICONE RUBBER.
 - PLASTIC BUSHING : THERMOPLASTIC , UL94 V-0.
- SPECIFICATIONS :
 - RATED CURRENT :
 - 2.1.1 STAMPED CONTACT 5A (MAX).
 - 2.1.2 MACHINED CONTACT, 7.5A(MAX).
 - RATED VOLTAGE : 250V (AC/DC) .
 - OPERATING TEMPERATURE : SEE CHART.
 - DIELECTRIC WITHSTANDING VOLTAGE : LESS THAN 2 MILLIAMPS CURRENT LEAKAGE@1500 VOLTS AC.
 - INSULATION RESISTANCE : 5000 MEGOHMS MIN.
 - IP--CLASS : IP67 (MATED CONDITION).
 - MATING CYCLES DURABILITY : 500 CYCLES(MIN).
 - RoHS COMPLIANT.
- SUITABLE CONTACTS : 20# CONTACTS.
- ALL DIMENSIONS ARE FOR REFERENCE USE ONLY.
- CONTACT SIZE AND REAR SEAL WIRE RANGE :

CONTACT SIZE	MIN. INSUL O.D.	MAX. INSUL O.D.
20#	Ø1.4mm	Ø2.0mm

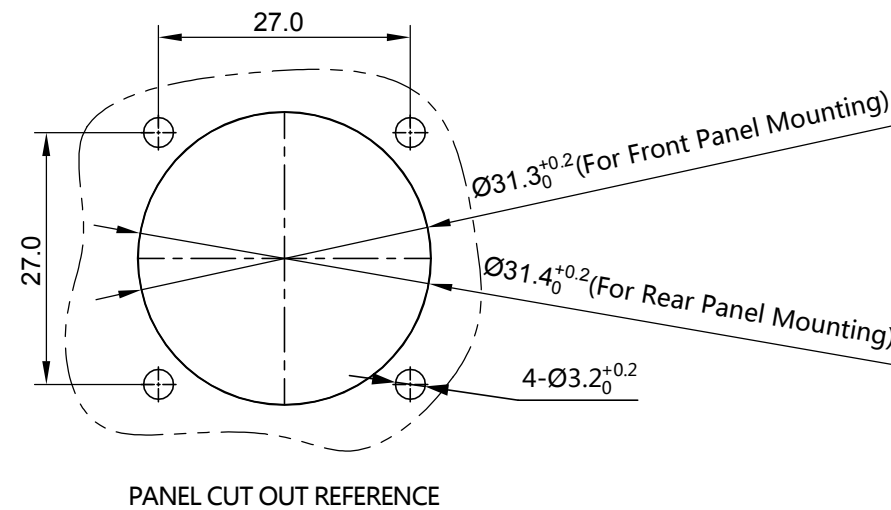

KEY POS	PART NUMBER	
	-40°C ~ 105°C	-40°C ~ 125°C
N	RT0W01832PNHEC	RT0W01832PNHEC03
W	RT0W01832PWHEC	RT0W01832PWHEC03
X	RT0W01832PXHEC	RT0W01832PXHEC03
Y	RT0W01832PYHEC	RT0W01832PYHEC03
Z	RT0W01832PZHEC	RT0W01832PZHEC03

QUANTITY	PART NUMBER	DESCRIPTION	ITEM
MATERIALS LIST			
UNLESS OTHERWISE SPECIFIED 1) All dimensions are in metric(mm). 2) Tolerances are as follows: 1 PL DEC ±0.30 2 PL DEC ±0.15 3 PL DEC ±0.08 Fractions ±1/64 Angles ±1° 3) Note reference =		SIGNATURES DRAWN: Ronald CHECKED: ENGINEER: APPROVAL: Tommy DATE Jan-7-2020 Jan-7-2020	 Sine Systems - www.amphenol-sine.com 44724 Morley Drive Clinton Township, MI 48036
MATERIAL SPECIFICATIONS:		CUSTOMER:	ECO-MATE,RECEPTACLE, SIZE 18,32POS,PIN,END CAP.
PROCESS SPECIFICATIONS:		THIS DRAWING IS SUPPLIED FOR INFORMATION ONLY. DESIGN FEATURES, SPECIFICATIONS AND PERFORMANCE DATA SHOWN HEREON ARE THE PROPERTY OF THE AMPHENOL CORPORATION. NO RIGHTS OF REPRODUCTION ARE IMPLIED. ALL DIMENSIONS ARE SUBJECT TO NORMAL MANUFACTURING VARIATIONS.	
NEXT ASSY:		SIZE: B C- SCALE: NONE DWG NO: RT0W01832P*HEC* REVISION: B3	
			SHEET 1 OF 1

TITLE: ECO-MATE RECEPTACLE SIZE 18,32POS,PIN,END CAP.
 DWG NO: RT0W01832P*HEC*
 REV: B3
 SH: 1
 OF: 1