

DESCRIPTION: M8 FEMALE - PANEL MOUNT (FRONT) - SOLDER CUP - 3 POS.

PANEL CUTOUT

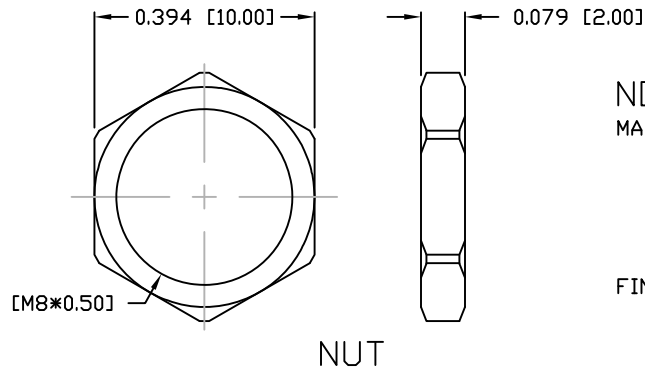

NOTE:
 MATERIAL
 HOUSING: PBT UL94V-0, BLACK
 CONTACT: BRASS
 SHELL: BRASS
 NUT: BRASS
 O-RING: EPDM, BLACK
 FINISH:
 CONTACT: GOLD PLATED OVER 50µ NICKEL
 SHELL: NICKEL
 NUT: NICKEL
 ELECTRICAL
 RATED CURRENT: 3A
 RATED VOLTAGE: 60V
 INSULATION RESISTANCE: 100 MΩhms MIN.
 CONTACT RESISTANCE: 10 mΩhms MAX.
 WATER PROOF: IP67
 ENVIRONMENT
 OPERATION TEMPERATURE: -40°C TO +85°C
 MAX WIRE AWG: 24 AWG

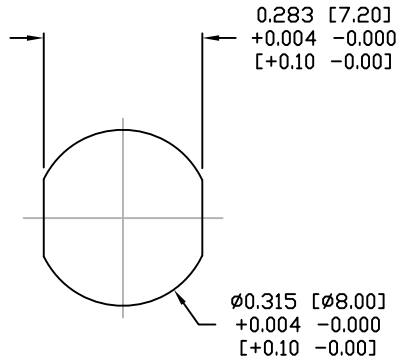
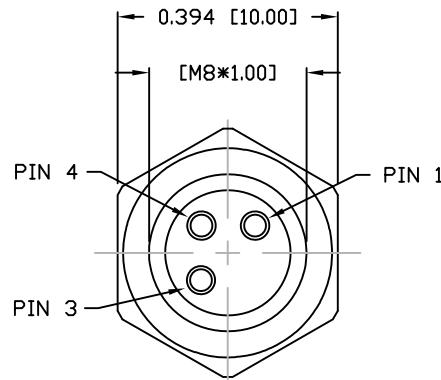
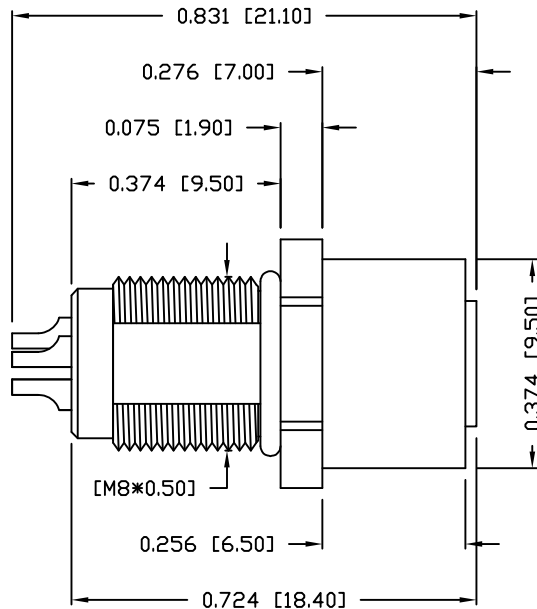

855-A03-203R00Y

1 = GOLD FLASH
 4 = 10µ" GOLD

RoHS COMPLIANT

UNITS = inch [mm]

DO NOT SCALE FROM DRAWING



THESE DRAWINGS AND SPECIFICATIONS ARE THE PROPERTY OF NorComp AND SHALL NOT BE REPRODUCED, COPIED OR USED AS THE BASIS FOR THE MANUFACTURE OR SALE OF APPARATUS WITHOUT WRITTEN PERMISSION.

DRAWN: M. SIGMON

DATE: 03-04-16

NorComp

SCALE: N.T.S. SHEET 1 OF 1 REV 3

DWG NO. 855-A03-203R00Y