

A

B

C

D

E

F

A

B

C

D

E

F

**NOTES:**

**MATERIAL**

- 1. Insulator Material: PBT+30%GF(UL94V-0), Black
- 2. Contact Material : Phosphor Bronze
- 3. Contact Plating : Gold flash/ Tin Over Ni

**ELECTRICAL**

- 1. Current Rating : 1AMP
- 2. Withstand Voltage : 500V AC/DC
- 3. Contact Resistance : 20mΩ max
- 4. Insulation Resistance: 1000MΩ min

**ENVIRONMENTAL**

- 1. Operation Temperature: -40°C to +105°C
- 2. Packing: Tray

No. of contacts: 06, 08, 10, 12, 14, 16, 18, 20, 22, 24, 26, 30, 34, 36, 40, 44, 50, 60, 64, 68

⑦ Wire Spec: AWG28

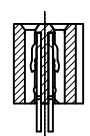
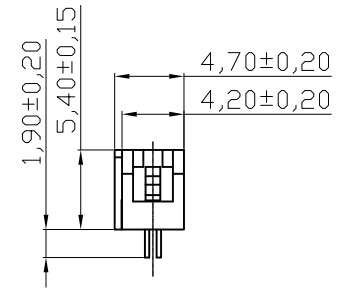
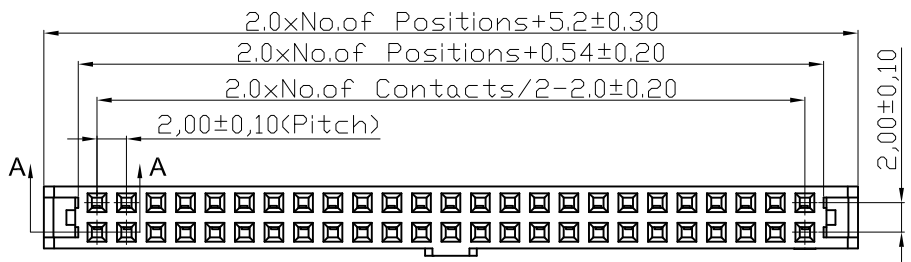

SECTION B-B

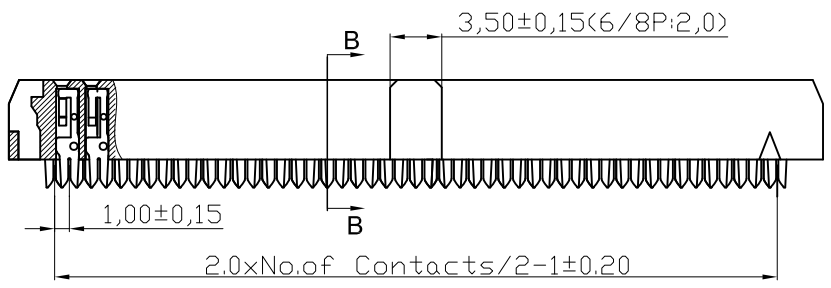

SECTION A-A

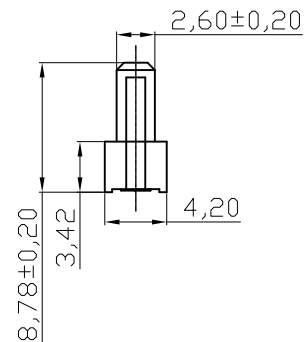
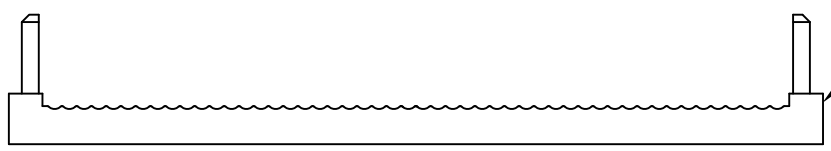

G

**RoHS compliant**  
unit:mm

Scale	Free
<b>TOLERANCE</b>	
.X	±0.35
.X	±0.25
.XX	±0.20
.XXX	±0.15
DIM	TOL
Angle	TOL

⑧	Update Description	15.03.2022	Winnie		Date	Name
⑦	Add wire spec	27.09.2016	Jesse	Drawn	25.01.2006	Alex
⑥	Add the UL-File No	13.12.2013	Winnie	Approved	27.09.2016	Jesse
⑤	Delete page 2	22.11.2013	Ray			
④	Added 68 Pin	24.12.2009	Dean			
③	Correct P/N	28.10.2009	Dean			
ld.	modification	Date	Name			



Description: ① DIN 41651 / IDC-socket 2.00mm pitch with central polarisation	
ASSMANN WSW-NO. <b>AWP2 xx-7240</b> ②	
Drawing-No. <b>ASS 2309 CO</b>	rev08
Customer-No.	SHEET 1 / 1

G

H