

PART NUMBER	REV	FIRST USED
680335-1	C	122500-1
680335-2	C	565435-5

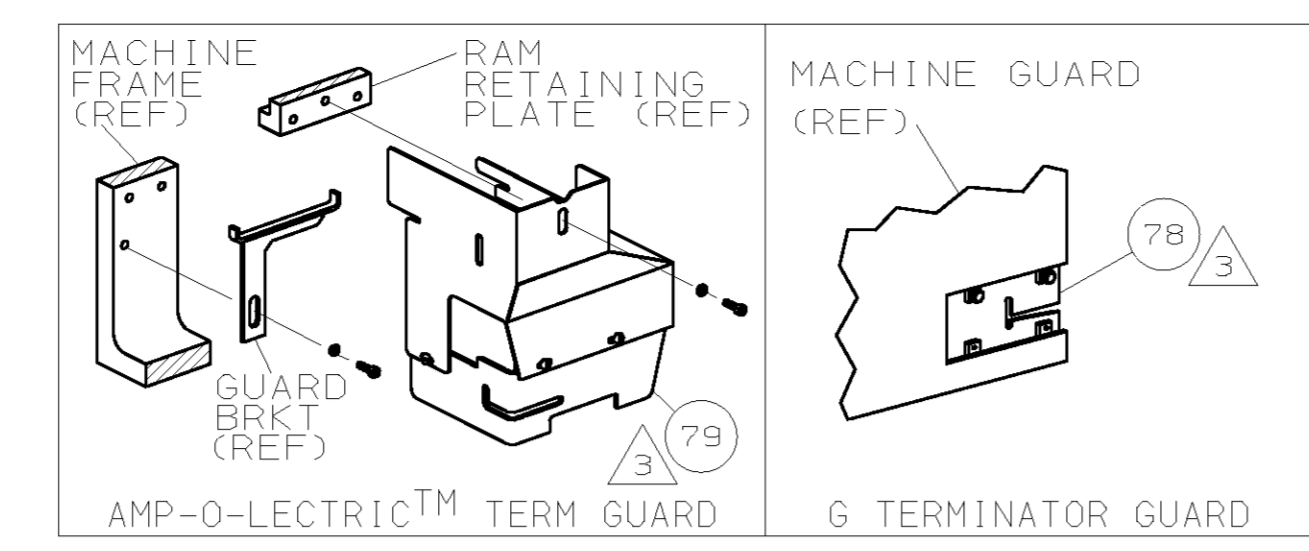

TERMINAL NAME: Ø.156 SHUR PLUG™ TERMINAL					
63925					
PAD LTR		CRIMP HEIGHT		WIRE SIZE	
A	.091 ±.002 [2.31 ±0.05mm]			12	
B	.099 ±.002 [2.51 ±0.05mm]			(2) 14	
C	.109 ±.002 [2.77 ±0.05mm]			10	
D	NOT USED				
CRIMP	SIZE	TYPE	RANGE		
WIRE	.140 [3.56mm]	F	12-10		
INSUL	-	-	-		
WIRE STRIP LENGTH	TERM APPL SPEC	FEED	APPL INSTRUCTION	SET UP GAGE	LAYOUT
.141-.171	114-2042	.805	408-8039	458638-1	L1793

-1	LEADMAKER & BENCH MODEL G	MECH POST FEED	
-2	BENCH MODEL K	MECH POST FEED	

REF	REF	-	A	22594-8	NUT, HEX	70
REF	REF	-	B	240628-1	PLATE, ADJ	69
REF	REF	-	B	240626-1	SHAFT, PIVOT	68
REF	REF	-	B	240633-1	BUSHING	67
REF	REF	-	A	455680-1	LEVER, INTERMEDIATE	66
REF	REF	-	B	240629-1	BLOCK, PIVOT	65
REF	REF	-	A	240632-2	SCR, ADJ	64
REF	REF	-	B	240659-3	PIN, CAM ROLLER	63
REF	REF	-	B	240658-1	CAM, ROLLER	62
REF	REF	-	B	454398-1	ROD, FEED	61

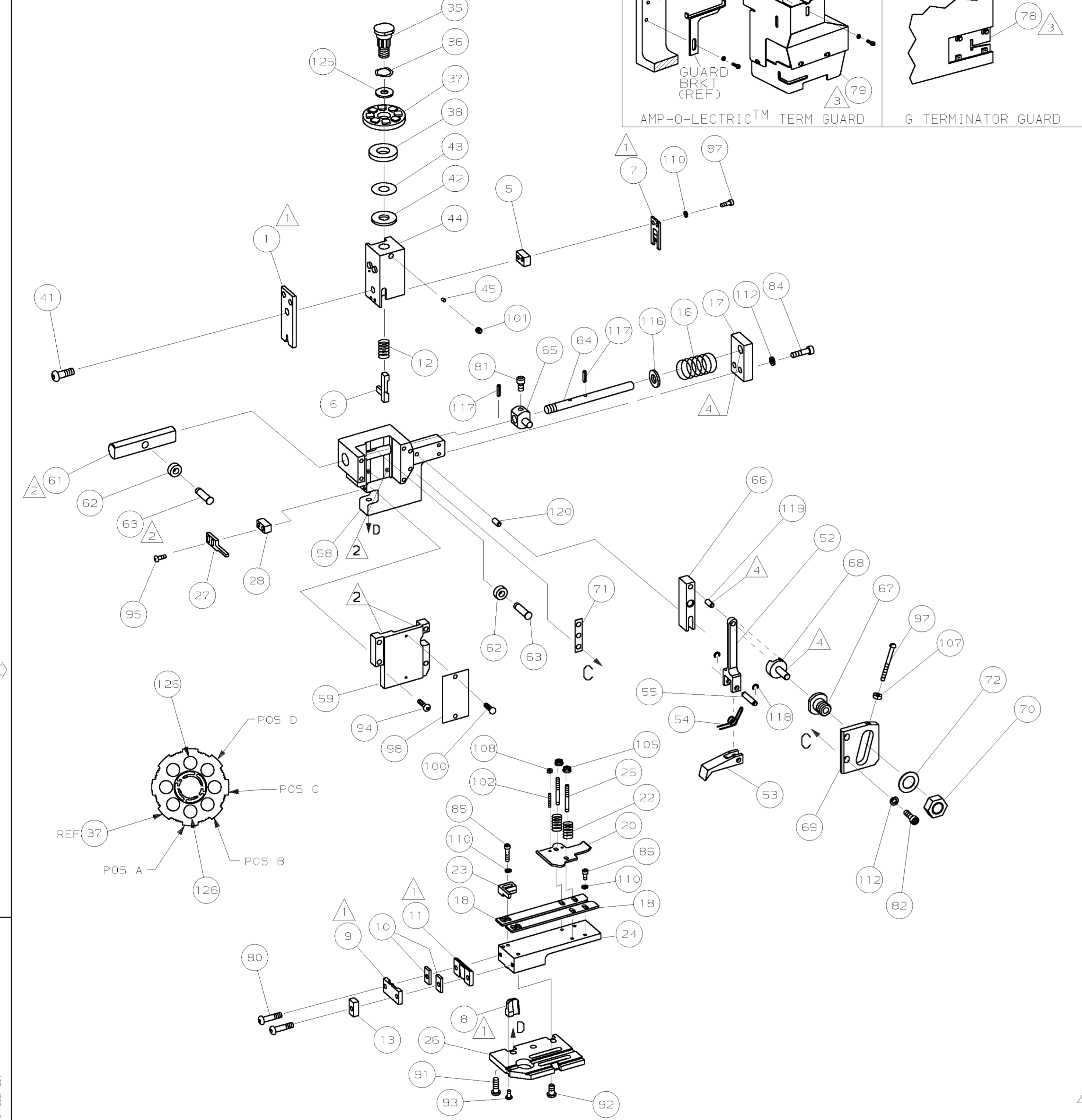

2	2	-	C	354778-3	PIN, WIRE DISC (.2510)C	129
2	2	-	C	2-345778-3	PIN, WIRE DISC (.2610)B	127
2	2	-	C	3-345778-9	PIN, WIRE DISC (.2690)A	126
1	1	-	A	986950-1	WASHER, FLAT PRECISION	125
1	1	-	A	217238-1	GENERAL INSTRUCTION PACKAGE	124
1	1	-	-	4088039	EF APPL INST 408-8039	123
						122
						121
REF	REF	-	A	1-21030-7	PIN, DOWEL (Ø.187x1.50)H5G	120
REF	REF	-	A	1-21030-1	PIN, DOWEL (Ø.187x.50)LEVER	119
REF	REF	-	A	21045-3	RING, RET "C" (Ø.187)FD PIN	118
REF	REF	-	A	5-21028-1	PIN, STD SPRING (Ø.12)FD ADJ ROD	117
REF	REF	-	A	21899-4	WASHER, FLAT (Ø5/16) SCR ADJ	116
						115
						114
						113
REF	REF	-	A	21024-5	WASHER, LOCK (NO.10)FD ROD GDE	112
						111
7	7	-	A	21024-4	WASHER, LOCK (NO.8)SHEAR BL	110
						109
2	2	-	A	21018-4	NUT, HEX (4-40)DRAG	108
REF	REF	-	A	21018-5	NUT, HEX (6-32)FD ADJ PL	107
						106
2	2	-	A	21022-2	NUT, HEX SL (8-32)DRAG STUD	105
						104
						103
2	2	-	A	2-21006-6	SCR, SKT SET (4-40x.62)DRAG	102
1	1	-	A	21009-2	SCR, SKT SET (1/4-20x.25)RAM	101
2	2	-	A	21017-2	SCR, DRIVE (#2x.19)ID PLATE	100
1	1	-	A	1-21002-7	SCR, BHC (6-32x.38)CAM	99
1	1	-	B	461264-1	PLATE, IDENTIFICATION	98
REF	REF	-	A	6-23715-5	SCR, PAN HD (6-32x1.50)FEED ADJ	97
						96
2	2	-	A	2-21002-2	SCR, BHC (8-32x.50)STRIPPER	95
REF	REF	-	A	2-21002-9	SCR, BHC (10-32x.75)H5G CAP	94
1	1	-	A	22733-8	SCR, BHC (8-32x.38 LW)ANVIL	93
4	4	-	A	3-21002-3	SCR, BHC (1/4-20x.50)ST 6D PL	92
REF	REF	-	A	2-22733-8	SCR, BHC (1/4-20x.62)BASE PL	91
						90
						89
						88
2	2	-	A	2-21000-8	SCR, 5HC (8-32x.62)SLUG BLADE	87
3	3	-	A	2-21000-6	SCR, 5HC (8-32x.38)STRIP GUIDE	86
2	2	-	A	2-21000-9	SCR, 5HC (8-32x.75)R STRIP GUIDE	85
REF	REF	-	A	3-21000-7	SCR, 5HC (10-32x.75)FEED ROD GDE	84
						83
REF	REF	-	A	3-21000-6	SCR, 5HC (10-32x.62)FEED ADJ PL	82
REF	REF	-	A	3-21000-4	SCR, 5HC (10-32x.38)PIVOT BLOCK	81
2	2	-	A	3-21002-0	SCR, BHC (10-32x.88)SHEAR PL	80
REF	-	-	A	455745-1	GUARD, WINDOW	79
-	REF	-	A	679532-1	INSERT, GUARD	78
						77
						76
						75
						74
						73
REF	REF	-	A	458109-1	WASHER, FLAT (SPECIAL)	72
REF	REF	-	A	690517-1	SPACER	71

						60
						59
REF	REF	-	C	454220-1	CAP, RAM	58
REF	REF	-	D	453736-1	HOUSING	57
						56
						55
REF	REF	-	B	240624-1	PIN, FEED FINGER	54
REF	REF	-	B	691499-1	SPRING, FEED FINGER	53
REF	REF	-	B	240635-1	FINGER, FEED	52
REF	REF	-	B	240634-1	LEVER, TERMINAL	51
						50
						49
1	-	-	B	690501-3	CAM, POST FEED 1 1/8 ST	48
-	1	-	B	690501-4	CAM, POST-FEED 1 5/8 ST	47
						46
1	1	-	A	690191-1	PLUG, NYLON	45
1	1	-	C	455674-1	RAM	44
1	1	-	A	690125-1	WASHER, LAMINATED	43
1	1	-	A	690124-1	WASHER, RAM	42
1	1	-	A	7-21002-9	BOLT, CRIMPER (5/16-24x1.00)	41
						40
						39
1	1	-	A	690223-2	SPACER, INSULATION DISC	38
1	1	-	D	354777-1	WIRE DISC, PLASTIC	37
1	1	-	A	22480-5	WASHER, SPRING	36
1	1	-	B	690212-1	POST, RAM	35
						34
						33
1	1	-	D	458980-1	APPLICATOR, BASIC (SUB ASSY)	32
						31
						30
						29
1	1	-	B	3-690451-2	SPACER, STRIPPER	28
1	1	-	A	240639-1	STRIPPER	27
REF	REF	-	C	455676-1	PLATE, BASE	26
2	2	-	A	22354-8	DRAG, STUD	25
1	1	-	B	455678-3	PLATE, STRIP GUIDE	24
1	1	-	C	240825-3	PLATE, STRIP HOLD DOWN	23
2	2	-	A	4-22281-1	SPRING, DRAG	22
						21
1	1	-	A	454177-1	DRAG, STOCK	20
						19
2	2	-	C	454204-3	GUIDE, STRIP (FRONT)	18
REF	REF	-	A	454178-1	GUIDE, FEED ROD	17
REF	REF	-	A	4-22284-9	SPRING, FEED RETURN	16
						15
						14
1	1	-	C	690481-2	SPACER, HOLD DOWN	13
1	1	-	A	23846-1	SPRING, HOLD DOWN	12
1	1	-	B	240644-5	PLATE, REAR SHEAR	11
2	2	-	C	6-240645-3	SPACER, SHEAR PLATE	10
1	1	-	B	690796-1	PLATE, FRONT SHEAR	9
1	1	-	D	240654-7	ANVIL	8
1	1	-	B	1-240651-9	BLADE, SLUG	7
1	1	-	D	2-455892-5	HOLD DOWN, TERMINAL	6
1	1	-	C	240641-3	SPACER, SLUG BLADE	5
						4
						3
						2
1	1	-	C	456425-9	CRIMPER, WIRE	1

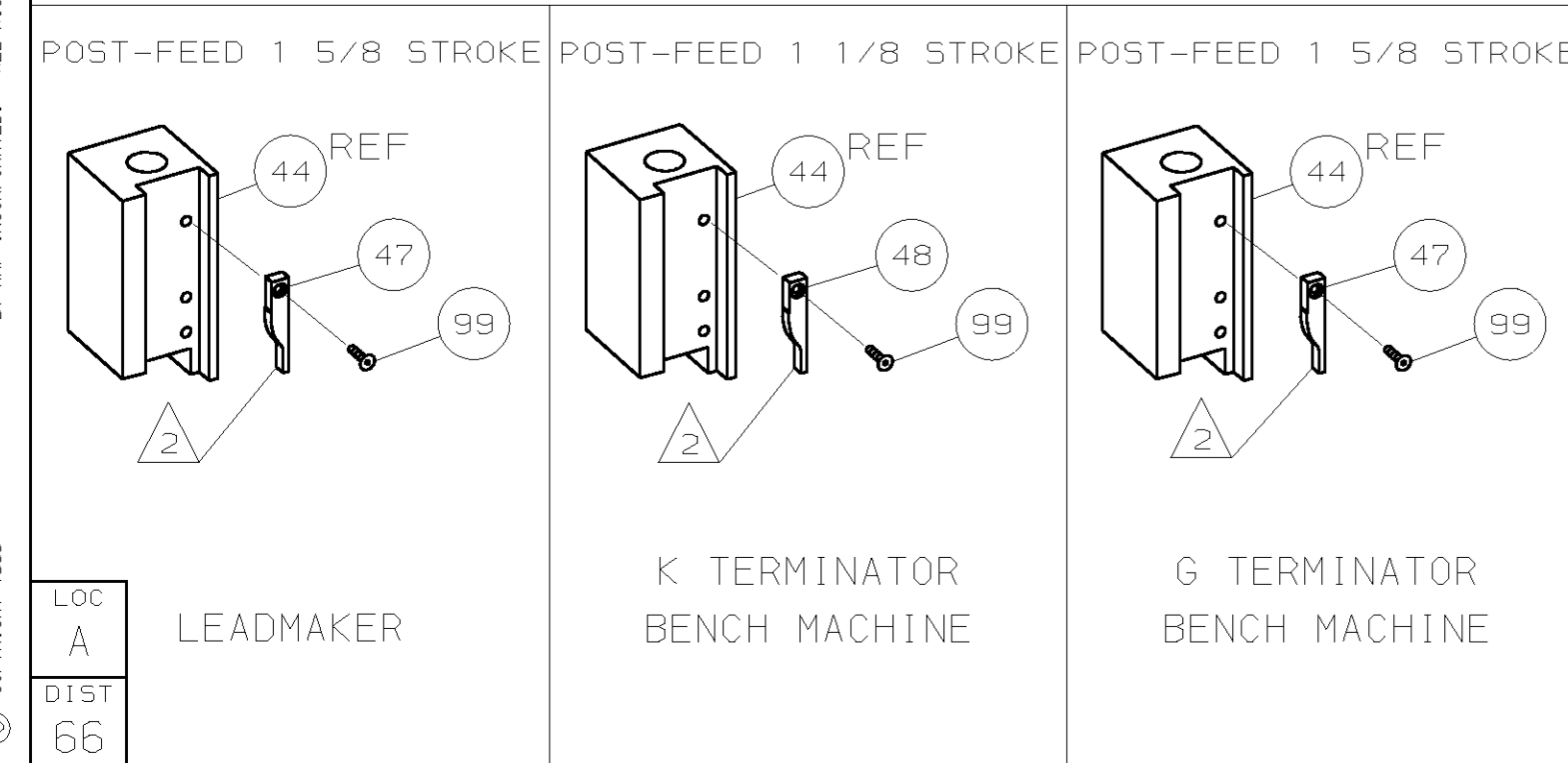

- 1 RECOMMENDED SPARE PARTS.
- 2 GREASE LIGHTLY.
- 3 GUARD MUST BE IN PLACE WHEN OPERATING APPLICATOR IN A BENCH MACHINE.
- 4 LUBRICATE DAILY USING NO. 20 MACHINE OIL.
- 5. ITEMS WITH QTY OF REF SPECIFIED (EXCEPT ITEMS 78 AND 79) ARE USED ON ITEM 32.
- 6 ITEM 78 USED WITH G TERMINATOR ONLY.

QTY REOD PER ASSY	U/M	DWG SIZE	PART NO	DESCRIPTION	ITEM NO
-2	-1				

QTY REOD PER ASSY	U/M	DWG SIZE	PART NO	DESCRIPTION	ITEM NO
-2	-1				